

LINK:
CONTENT & A-Z



The Ultimate
Driving Machine



OWNER'S HANDBOOK.

 **BMW i4 GRAN COUPÉ.**

BIMMERPOST

Link for Part no. 01405A48801 - X/21



WELCOME TO BMW i.

Owner's Handbook.

Congratulations on your choice of a BMW i.

The better you are acquainted with your vehicle, the easier you will find it is to operate. We would therefore like to offer you the following advice:

Please read the Owner's Handbook before setting out in your new BMW i. Also use the integrated Owner's Handbook in your vehicle. It contains important notes on how to operate the car, enabling you to derive maximum benefit from the technical advantages of your BMW i. It also contains information which will help you to maintain both the operating safety and road safety of your BMW i's as well as its full resale value.

When the vehicle leaves the factory, the printed Owner's Handbook is the most up-to-date version. After a vehicle software update – for example, a Remote Software Upgrade – the Integrated Owner's Handbook for the vehicle will contain updated information.

Supplementary information is provided in the other documents of on-board literature.

We wish you a safe and pleasant journey.

TABLE OF CONTENTS

After a vehicle software update – for example, a Remote Software Upgrade – the Integrated Owner's Handbook for the vehicle will contain updated information.

! NOTES

Notes	6
Safety of the high-voltage system	21
Owner's Handbook media	23

🔑 QUICK REFERENCE

Getting in	26
Adjustment and operation	30
On the move	35

👇 CONTROLS

Vehicle cockpit	42
Sensors in the vehicle	47
Vehicle operating condition	51
iDrive	54
BMW Remote Software Upgrade	66
Personal settings	70
Connections	75
Opening and closing	84
Seats, mirrors and steering wheel	110
Carrying children safely	124
Driving	135
Displays	153
Lights	177
Safety	186
Driving stability control systems	220
Driver assistance systems	224
Parking	251
Driving comfort	271
Air conditioning	273

Interior equipment	282
Storage compartments	288
Luggage compartment	292

DRIVING HINTS

Driving precautions	298
Trailer operation	303
Increasing range	309

MOBILITY

Charging vehicle	316
Wheels and tyres	327
Under the bonnet	352
Operating fluids	354
Maintenance	357
Replacing parts	360
Help in case of a breakdown	364
Care	373

REFERENCE

Technical data	378
Seats for child restraint systems	381
Appendix	383
Everything from A to Z	384

© 2021 Bayerische Motoren Werke

Aktiengesellschaft

Munich, Germany

Not to be reproduced, wholly or in part, without written permission from BMW AG, Munich.

English ID8 X/21, -

Printed on environmentally friendly paper, bleached without chlorine, suitable for recycling.

Notes

About this Owner's Handbook

Orientation

The quickest way to find information on a particular topic or feature is to consult the alphabetical index.

We recommend that you read through the first chapter to obtain an initial overview of the vehicle.

Validity of Owner's Handbook

Vehicle production

At the time of production in the factory, the printed Owner's Handbook provides up-to-date information. Updates following the copy deadline can result in differences between the printed Owner's Handbook and the integrated Owner's Handbook in the vehicle.

Notes on updates can be found in the appendix of the printed Owner's Handbook for the vehicle.

After a software update in the vehicle

After a vehicle software update, for example, via Remote Software Upgrade, the Integrated Owner's Handbook for the vehicle will contain the latest information.

Owner's Handbook for Navigation, Entertainment, Communication

The Owner's Handbook for Navigation, Entertainment and Communication is available as a printed book from Service.

These topics are also covered in the integrated Owner's Handbook in the vehicle.

Additional sources of information

Service Partner

A Service Partner of the manufacturer will be happy to answer any further questions.

Internet

Vehicle information and general information on BMW – on technology, for example – are available on the Internet: www.bmw.com.

Integrated Owner's Handbook in the vehicle

The Integrated Owner's Handbook shows all standard equipment, national-market equipment and optional equipment which is offered or will be offered on a model-specific basis. The integrated Owner's Handbook can be shown on the control display.

BMW Driver's Guide App



The BMW Driver's Guide App shows all standard equipment, national-market equipment and optional equipment which is offered or will be offered on a model-specific basis. The app can be displayed on smartphones and tablets.

BMW Driver's Guide web version

Driver's Guide web version shows all standard equipment, national-market equipment and optional equipment which is offered or will be offered on a model-specific basis. The Driver's Guide web version can be displayed in any up-to-date browser.

Symbols and displays

Symbols in the Owner's Handbook

Symbol	Meaning
	Precautions that must be followed in order to avoid the possibility of injury to yourself and to others as well as serious damage to the vehicle.
	Measures that can be taken to help protect the environment.
"..."	Texts on a display in the vehicle for selecting functions.
>...<	Commands for the voice control system.
»...«	Replies by the voice control system.

Actions

Actions that need to be carried out are shown as a numbered list. The list of steps must be carried out in the specified sequence.

1. First action.
2. Second action.

Lists

Alternative options and lists of items with no implied sequence are shown as bullet point lists:

- ▶ First option.
- ▶ Second option.

Symbol on components and assemblies

 This symbol on a vehicle component indicates that further information on the component is available in the Owner's Handbook.

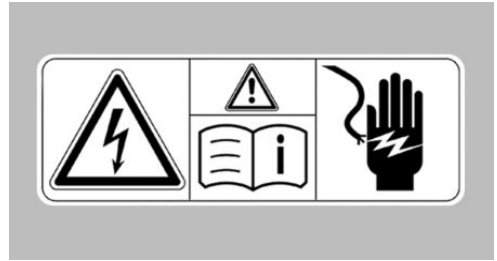

The symbols on parts of the vehicle indicate that life-threatening injury could occur as a result of electric shock if the high-voltage technology or the orange-coloured high-voltage components are used inappropriately.

Vehicle equipment

This Owner's Handbook shows all models and all standard equipment, national-market equipment and optional equipment which is offered or will be offered on a model-specific basis, i.e. in the model range. As a result, this Owner's Handbook may also contain descriptions and illustrations of equipment, systems and functions which are not installed in the vehicle in question, for example due to:

- ▶ Selected optional equipment.
- ▶ National-market version or national-market equipment.
- ▶ Possibility of subsequent enabling and software updates.

This also applies to safety-relevant functions and systems.

Before starting a journey, check whether a piece of equipment or a function that is described is available in the vehicle. Information about whether a function is currently available in the vehicle or whether and when the function can be installed in the vehicle can be obtained from a Service Partner of the manufacturer or another qualified Service Partner.

If a piece of equipment, system or function is described in the Owner's Handbook, this does not mean that it will be available in the vehicle.

Please comply with the relevant laws and regulations when using the corresponding functions and systems.

If certain equipment and models are not described in this Owner's Handbook, refer to the Supplementary Owner's Handbooks provided.

In right-hand drive vehicles, some operating elements are arranged differently from those shown in this Owner's Handbook.

Production date

The production date of your vehicle can be found at the bottom of the door pillar on the driver's door.

The production date is defined as the calendar month and the calendar year in which the vehicle body and the powertrain assemblies are joined and the vehicle is driven or moved from the production line.

Status of the Owner's Handbook

General

The high standards of safety and quality that characterise the vehicles are ensured through ongoing development. On rare occasions, this may mean that the features described in this handbook will vary from those in your vehicle.

For Australia/New Zealand: general

When reading this Owner's Handbook, please bear the following in mind: to ensure that our vehicles continue to embody the highest quality and safety standards, we pursue a policy of continuous, ongoing development. Because modifications in the design of both vehicles and accessories may be introduced at any time, your own

vehicle's equipment may vary from that described in this handbook. For the same reason, it is also impossible to guarantee that all descriptions will be completely accurate in all respects.

We must therefore request your understanding of the fact that the manufacturer of your vehicle is unable to recognise legal claims based on discrepancies between the data, illustrations and descriptions in this Owner's Handbook and your own vehicle's equipment. Please note, too, that some of the optional equipment described in this manual is not available on Australian models due to restrictions imposed by Australian Design Rules and other requirements.

Should you require any further information, please contact your Service centre, who will be pleased to advise you.

Validity of Owner's Handbook

Vehicle production

At the time of production in the factory, the printed Owner's Handbook provides up-to-date information. Updates following the copy deadline can result in differences between the printed Owner's Handbook and the integrated Owner's Handbook in the vehicle.

Notes on updates can be found in the appendix of the printed Owner's Handbook for the vehicle.

After a software update in the vehicle

After a vehicle software update, for example, via Remote Software Upgrade, the Integrated Owner's Handbook for the vehicle will contain the latest information.

Your own safety

Intended use

Please comply with the following when using the vehicle:

- ▶ Owner's Handbook.
- ▶ Information attached to the vehicle. Do not remove stickers.
- ▶ Technical data of the vehicle.
- ▶ The applicable laws and safety standards of the country in which the vehicle is used.
- ▶ Vehicle papers and legal documents.

Warranty

The vehicle is technically designed for the operating conditions and approval (homologation) requirements of the country to which it was first delivered. If the vehicle is to be driven in another country, it may need to be adapted beforehand to any different operating conditions and approval requirements prevailing in that country. If the vehicle does not comply with the homologation requirements in a certain country, no warranty claims can be lodged there for the vehicle. Warranty claims may also be invalidated if the electrical system has been modified, for example through the use of control units, hardware or software which the vehicle manufacturer classifies as unsuitable. A Service Partner is able to provide further information.

Note: in addition to the statutory warranty, the selling Authorised BMW Retailers or the selling BMW AG branches in Germany are granting additional benefits with the purchase of new BMW vehicles within the framework of the BMW Warranty Booklet. More information: www.bmw.de/qualitaetsbrief.

Maintenance and repairs

The advanced technology used in your vehicle, for example the state-of-the-art materials and high-performance electronics, requires appropriate maintenance and repair methods.

Consequently, the manufacturer of the vehicle recommends having corresponding work carried out by a BMW Service Partner. If another BMW authorised workshop is chosen, BMW recommends choosing one that performs work, for example maintenance and repair, according to

BMW specifications with properly trained personnel. In the Owner's Handbook, facilities of this kind are referred to as "another qualified Service Partner or a specialist workshop".

If work such as maintenance and repair is carried out incorrectly, it could result in consequential damage with associated safety risks.

Work performed incorrectly on the vehicle paintwork can cause components, for example the radar sensors, to fail or malfunction, resulting in a safety risk.

Parts and accessories

BMW recommends using parts and accessories that are approved by BMW and are therefore suitable for this purpose.

You are recommended to consult a BMW Service Partner for advice on genuine BMW parts and accessories, other BMW approved products and expert advice on all related matters.

The safety and compatibility of these products in conjunction with BMW vehicles have been checked by BMW.

BMW accepts product responsibility for genuine BMW parts and accessories. On the other hand, BMW cannot accept liability for parts or accessory products of any kind which it has not approved.

BMW is unable to assess each individual product of outside origin as to its suitability for use on BMW vehicles without safety risk. Likewise no guarantee can be assumed even if the product has been granted official approval in a specific country. Tests performed for such approvals cannot always cover all operating conditions for BMW vehicles, and some of them therefore are insufficient.

Vehicle data and data protection

Responsibility and rights

Responsibility for data

Within the scope of data protection directives and legislation, the manufacturer of the vehicle is responsible for the processing of personal data which is collected when the vehicle is used or from web pages, customer support, online services and marketing campaigns.

Personal identification

Every vehicle has a unique vehicle identification number. Depending on the country, and with the assistance of the relevant authorities, the registered keeper can be identified from the vehicle identification number and the number plate.

There are also other ways of tracing data collected in the vehicle back to the driver or registered keeper, for example via the ConnectedDrive account used.

Data protection laws

In accordance with current data protection law, vehicle users have certain rights vis-à-vis the vehicle manufacturer or companies that collect or process their personal data.

Vehicle users have a free and comprehensive right of access to their personal data which has been collected and held by organisations.

Such organisations could be:

- ▶ Vehicle manufacturer.
- ▶ Qualified Service Partners.
- ▶ Specialist workshops.
- ▶ Service providers.

Vehicle users may request information about what personal data has been saved, what it is used for and where it has come from. Proof of ownership or use is required in order to obtain this information.

The right of access also extends to information about data that has been transferred to other companies or bodies.

Please refer to the vehicle manufacturer's web page for the applicable data protection policy. This data protection policy contains information about the right to have data deleted or corrected. The vehicle manufacturer's website also provides its contact details and those of its data protection officer.

The registered keeper can have the data stored in the vehicle read out by a Service Partner of the manufacturer or another qualified Service Partner or a specialist workshop, on payment of a fee where applicable.

The legally required OBD diagnostic socket in the vehicle is used to read out the vehicle data.

Data processing

The collection of personal data may be necessary to enable the manufacturer of the vehicle to fulfil obligations to the customer or legislator or to offer high-quality products and services.

These include, for example:

- ▶ To fulfill contractual obligations regarding the sale, servicing and repair of vehicles, for example sales processes, maintenance.
- ▶ To fulfill contractual obligations regarding the provision of digital vehicle services, for example BMW ConnectedDrive.
- ▶ To safeguard product quality and the research and development of new products, and to optimise service processes.
- ▶ To perform sales, service and administration processes, including branches and National Sales Companies.
- ▶ To provide customer support, for example contract processing.
- ▶ To conduct advertising communication and market research on the basis of personal consent.

- ▶ To fulfill legal obligations, for example information regarding Technical Campaigns.
- ▶ To process warranty claims.

Data collection

Type of data collected

Depending on the situation, the following personal data may be collected.

Contact details

Name, address, phone number, email address.

Personal data

- ▶ Personal information provided by customers, for example date of birth, education, household size or occupation.
- ▶ Data to determine identity, for example driver's licence.

Contract data

- ▶ Customer number, contract number, booked online services.
- ▶ Stored payment information, for example credit card number.

Credit rating

- ▶ Information about transactions.
- ▶ Information about fraud or criminal offences.

Interests

Information provided by the customer regarding areas of interest, for example product preferences, hobbies and other personal preferences.

Use of web pages and communication

- ▶ Information on how web pages are used and whether messages are opened or forwarded.
- ▶ Account information regarding online services, customer portals and prospective customer portals.

Transaction and interaction data

Information on the purchasing of products and services, interactions with customer support and participation in market research studies.

Use of apps and services of the vehicle manufacturer

Information on the use of apps on mobile devices and online services.

Information on vehicle functions and settings

Information on functions and settings in the vehicle, for example when using online services.

Vehicle-related sensor data and usage data

Data which is generated and/or processed in the vehicle.

- ▶ Driver assistance systems: processing of sensor data which is used to evaluate the vehicle's surroundings or the driver's behaviour.
- ▶ Personal settings: settings saved in the vehicle profile, for example seat setting.
- ▶ Multimedia, navigation, for example destinations.

Time of data collection

Personal data may be collected at the following times:

- ▶ When the customer makes direct contact with the manufacturer of the vehicle, for example via the web page.
- ▶ When requesting information on products and services or direct purchases, for example on web pages or in apps.
- ▶ When making direct purchases, for example on the web page.
- ▶ When purchasing services directly, for example online services.
- ▶ When the customer responds to direct marketing activities, for example when personal data is provided.

- ▶ When using vehicles, products, services and digital offers, for example web pages, apps.
- ▶ When communicating personal data through qualified partners of the vehicle manufacturer or through third-party providers, provided that data protection requirements are met.
- ▶ When providing personal data through certified address providers, provided that data protection requirements are met.
- ▶ When vehicle data, including the vehicle identification number, is read out during service, maintenance and repair activities.

Data in the vehicle

General

A number of electronic control devices are installed in your vehicle. Electronic control units process data that they receive from vehicle sensors, generate themselves or exchange with one another, for example. Many of the control units are necessary for safe operation of the vehicle, or provide assistance during a journey, for example driver assistance systems. There are also control devices which manage comfort or infotainment functions.

Data saved in the vehicle can be deleted at any time. This data is only transmitted to third parties if expressly requested in the course of using on-line services. The transfer depends on the settings selected for using the services.

Sensor data

Driver assistance systems, for example Active Cruise Control, Collision Warning or Attentiveness Assistant, process sensor data which is used to evaluate the vehicle's surroundings or the driver's behaviour.

These include, for example:

- ▶ Status messages relating to the vehicle and its individual components, for example wheel speed, wheel circumferential velocity, decel-

eration, lateral acceleration, fastened seat belts.

- ▶ Ambient conditions, for example temperature, rain sensor signals.

The data is processed within the vehicle and is usually transient. It is only saved for longer than the operating period if it is required in order to provide services agreed with the customer.

Electronic components

Electronic components, for example control devices and vehicle keys, contain components for storing technical information. Information about the vehicle condition, component use and wear, maintenance requirements, events or faults can be stored temporarily or permanently.

This information generally documents the condition of a component, a module, a system or the vehicle's surroundings, including:

- ▶ Operating states of system components, for example fill levels, tyre inflation pressure, battery status.
- ▶ Malfunctions and faults of important system components, for example lights and brakes.
- ▶ Responses of the vehicle to particular driving situations, for example triggering of an airbag, activation of the driving stability control systems.
- ▶ Information on vehicle-damaging events.

The data is required so that the control units can perform their functions. It is also used for detecting and rectifying malfunctions, as well as to optimise vehicle functions.

Most of this data is transient and is only processed within the vehicle itself. Only a small proportion of the data is stored in event or fault memories in response to specific circumstances.

Personal settings

Convenience functions, such as seat, climate or light settings, enhance the driving experience. The personal settings for these functions can be saved in a BMW ID or in a profile within the vehi-

cle and retrieved as required, for example if the settings have been changed in the meantime by another driver. Depending on the equipment, these profiles can be saved in the vehicle manufacturer's secure data systems. When the driver changes vehicle, these saved profiles can simply be applied to a different vehicle.

The vehicle settings stored in a BMW ID or vehicle profile can be changed or deleted at any time.

Multimedia and navigation

Data can be additionally imported into the vehicle entertainment and communication system, for example, via smartphone. The imported data can be processed within the vehicle, for example to play the user's favourite music.

Depending on the equipment, this data includes:

- ▶ Multimedia data such as music or photos for playback in an integrated multimedia system.
- ▶ Address book data for use in conjunction with an integrated hands-free system or an integrated navigation system.
- ▶ Destinations: depending on the equipment, route guidance can be started automatically using destinations learned by the navigation system.
- ▶ Data on usage of Internet services.

This data may be saved locally in the vehicle or stored on a device that has been connected to the vehicle, for example, a smartphone or USB stick.

Service data

General

When services are required, for example repairs, service operations, warranty work and quality assurance measures, this technical information can be read out from the vehicle together with the vehicle identification number.

Stored data

Electronic vehicle components may contain data storage medium which store technical information relating to the vehicle condition, events and faults. The data required for service measures is processed locally and is deleted automatically once the work is complete. A Service Partner of the manufacturer or another qualified Service Partner or a specialist workshop can read out the information. As part of service and repair work, data is read out via the OBD diagnostic socket using special diagnosis systems and transferred to the vehicle manufacturer. The customer is entitled to withhold consent to the data being read out and forwarded.

Optimising service processes

The vehicle manufacturer maintains documentation relating to each vehicle to ensure the best possible service is provided. Within the scope of legal requirements, this documentation may be made available to authorised third parties, for example specialist workshops.

The authorised third parties may only use this data for the purposes of performing the service or repair order in question. This prevents work from being duplicated unnecessarily on the vehicle, for example.

Ensuring product quality

The data logs the technical conditions of the vehicle and helps in locating faults, complying with warranty obligations and improving quality.

To ensure product quality and the development of new products, data on the usage of individual components and systems, for example, lights, brake, electric windows, displays, can be read out. This data helps the vehicle manufacturer to optimise the design of components and systems. Data analysis also provides the basis for Technical Campaigns and statutory recalls.

Furthermore, the manufacturer has product monitoring obligations to meet in line with product liability law. To fulfil these obligations, the ve-

vehicle manufacturer requires technical data from the vehicle.

Goodwill and warranty claims

Data from the vehicle can also be used to check customer warranty claims. If goodwill or warranty claims are asserted, the data is read out and transferred to the vehicle manufacturer to resolve the claims promptly.

Fault and event memories in the vehicle can be reset when a Service Partner of the manufacturer or another qualified Service Partner or a specialist workshop performs repair or servicing work.

Control over data

The transfer of data to the vehicle manufacturer for the purposes of ensuring product quality or optimising service processes can be stopped on request.

Legal requirements regarding data disclosure

According to current law, the vehicle manufacturer is obliged to provide the authorities with any data it has stored. Data is provided to the extent required and on a case-by-case basis, for example to investigate a criminal offence.

The current law also gives state bodies authorisation to read out data from the vehicle themselves for individual cases. This could include reading out data from the airbag control unit to shed light on the circumstances of an accident, for example.

In the context of legal obligations within the EU, certain vehicle consumption data, so-called OBCFCM data, are transmitted to the EU Commission via the vehicle manufacturer, e.g. fuel or energy consumption and the distance covered. The registered keeper can refuse to provide this data for this purpose.

Mobile devices

Depending on the equipment, mobile devices such as smartphones can be connected to the

vehicle and used to control vehicle functions, for example BMW Connected, Apple CarPlay. Sound and images from the mobile device may be played back or displayed through the multimedia system in the vehicle, for example.

Selected information is transferred to the mobile device at the same time. Depending on the type of integration, this includes position data and other general vehicle information, for example. This enables optimum use of selected apps, for example navigation and music playback. How the data is processed further is determined by the provider of the particular app being used.

Services

General

If the vehicle has a wireless network connection, data can be exchanged between the vehicle and other systems, for example with BMW ConnectedDrive.

Services from the vehicle manufacturer

The various functions of online services provided by the vehicle manufacturer are described at appropriate points, for example in the Owner's Handbook or on the manufacturer's web page. The relevant legal information pertaining to data protection is also given.

Personal data may be used to provide online services. Data is exchanged over a secure connection, for example with the vehicle manufacturer's data systems set up for this purpose.

Any collection, processing and use of personal data above and beyond that needed to provide the services always requires legal permission, a contractual agreement or consent of the user.

BMW ConnectedDrive

BMW ConnectedDrive networks the vehicle with a number of digital services. When these services are used, only the data stored in the vehicle and required to provide the service is transferred online, for example information on identifying and

locating the vehicle. Usage is based on a contractual agreement with the user.

In individual cases, the transfer of data is triggered as a result of predefined events, such as an intelligent emergency call. The wireless network connection is established via an in-vehicle transmitter and receiver unit or via personal mobile devices brought into the vehicle, for example smartphones. Data transfer can be deactivated on request.

The wireless network connection enables online functions to be used. These include online services and apps supplied by the vehicle manufacturer or by other providers.

Services from other providers

When using online services from other providers, these services are the responsibility of the relevant provider and subject to their data protection conditions and terms of use. The vehicle manufacturer has no influence over the data that is exchanged.

Information as to how personal data is collected and used in relation to services from third parties, the scope of such data and its purpose, can be obtained from the relevant provider.

Personal decision

Every user decides for themselves whether they wish to enter into a contract for a service such as BMW ConnectedDrive. Information on the extent of data processing and the content involved is provided in writing before the service is acquired and forms part of the vehicle handover.

The user has the option to deactivate the services at any time and consequently to stop the data processing required for the services. It is also possible to have the entire data connection activated or deactivated. Excluded from this are functions and services which are required by law, for example emergency call systems.

Transparency concerning vehicle data

BMW CarData provides transparency in handling vehicle data with the use of BMW ConnectedDrive. BMW CarData enables users to control whether vehicle data being processed in the context of BMW ConnectedDrive is transferred to third parties. Users can decide for each individual service offering whether data access is to be granted or refused to third parties, for example to insurance companies.

An archive can also be requested from BMW CarData at any time. The archive provides information on the data that has been transmitted and saved in the context of BMW ConnectedDrive. BMW CarData can only be accessed by third-party providers via the vehicle manufacturer's servers. Direct access to the vehicle and its data is not permitted.

More information on BMW CarData is available on the BMW ConnectedDrive customer portal.

Statutory emergency call system

Principle

The eCall emergency call system required by law enables manual or automatic emergency calls to be made, for example in the event of an accident.

The emergency calls are answered by the public rescue coordination centre.

General

For information on the eCall statutory on-board emergency call system based on the 112 emergency call, as well as its operation and its functions, see the chapter on emergency calls.

The eCall service based on the 112 emergency call is a public service of general interest and is provided free of charge.

If a serious accident occurs, the eCall statutory emergency call system is activated automatically by on-board sensors as standard practice. It is also triggered automatically if the vehicle is equipped with an intelligent emergency call sys-

tem that fails to work in the event of a serious accident.

The eCall statutory emergency call system can also be triggered manually if required.

If a critical system failure occurs that would put the eCall statutory emergency call system out of operation, the vehicle occupants receive a warning.

For further information:

- ▷ Emergency call, see page 366.
- ▷ Malfunction, see page 367.

Information on data processing

The eCall statutory emergency call system processes personal data in accordance with the following regulations:

- ▷ Protection of personal data: Regulation (EU) 2016/679 of the European Parliament and of the Council.
- ▷ Protection of personal data: Directive 2002/58/EC of the European Parliament and of the Council.

Personal data is only processed for the purpose of transmitting eCall emergency calls to the single European emergency call number 112.

SIM card

The eCall statutory emergency call system operates via mobile radio through the SIM card installed in the vehicle. The SIM card is not permanently connected to the mobile phone network; rather, it remains connected only as long as the emergency call is active.

Data types and their recipients

The eCall statutory emergency call system may only collect and process the following data:

- ▷ The vehicle identification number for rapidly identifying the vehicle, for example the model.
- ▷ Vehicle type, for example passenger car.
- ▷ Type of vehicle drive, for example petrol or diesel, for assessing the risks involved in a

rescue, for example the risk of fire caused by fuel.

- ▷ The vehicle's position at the time of the accident, its last three locations and the direction of travel in order to locate the vehicle more quickly on very complex route sections, for example.
- ▷ A log of the automatic system activation, along with the time stamp.
- ▷ Control information, which tells rescue services whether the emergency call was triggered automatically or manually, for example.
- ▷ A time stamp for determining the time of the accident in order to optimise the deployment plans of the rescue services.
- ▷ The direction of travel for establishing which side of the carriageway is affected, for example.

The authorities of the state in whose territory the eCall system emergency call is made determine which emergency call centres receive and process the statutory emergency call.

Data processing configuration

The eCall statutory emergency call system ensures that the data contained in the system memory cannot be accessed outside the system before an emergency call is triggered.

The data collected for the eCall statutory emergency call system is only saved in the vehicle and sent to the rescue coordination centre when an emergency call is triggered.

The eCall statutory emergency call system ensures that it cannot be traced and there is no permanent tracking during normal operation.

The eCall statutory emergency call system ensures that the data in the internal system memory is deleted automatically and continuously.

The vehicle's location data is continuously overwritten in the system's internal memory so that only the vehicle's last three locations - which the system needs for normal operation - are ever stored.

The activity data log of the eCall statutory emergency call system is retained only for as long as is necessary to handle the eCall emergency call and under no circumstances for any longer than 13 hours after the eCall emergency call was triggered.

Rights of individuals affected by data processing

The individual affected by data processing, for example the registered keeper, has the right to access the data and can request that data concerning him or her that is not processed in accordance with the statutory regulations be corrected, deleted or blocked as applicable. Each time that data is corrected, deleted or blocked in line with these regulations, the third parties to whom the data was transmitted must be notified, insofar as this is reasonably practical.

The individual affected by data processing has the right to complain to the relevant data protection body if he or she believes that his or her rights have been violated as a result of having their personal data processed.

For matters relating to access rights, please contact a Service Partner of the manufacturer or another qualified Service Partner or a specialist workshop.

Intelligent emergency call system

Principle

The intelligent emergency call system enables manual or automatic emergency calls to be placed, for example in the event of an accident.

The emergency calls are answered by an emergency call centre appointed by the vehicle manufacturer.

In addition to the intelligent emergency call system, the eCall statutory emergency call system is present in the vehicle and is active depending on the situation.

The registered keeper has the right to use either the intelligent emergency call system or the eCall statutory emergency call system.

For further information:

Emergency call, see page 366.

Legal basis

The intelligent emergency call system processes personal data in accordance with the following regulations:

- ▶ Protection of personal data: Regulation (EU) 2016/679 of the European Parliament and of the Council.
- ▶ Protection of personal data: Directive 2002/58/EC of the European Parliament and of the Council.

The ConnectedDrive contract concluded for this function, as well as the relevant laws, ordinances and directives of the European Parliament and the European Council provide the legal basis for the activation and function of the intelligent emergency call system.

The relevant ordinances and directives govern the protection of individuals in terms of processing personal data.

The intelligent emergency call system processes personal data in accordance with European directives on the protection of personal data.

The intelligent emergency call system processes personal data only with the registered keeper's consent.

The intelligent emergency call system and other added-value services may only process personal data with the express consent of the individual affected by data processing, for example the registered keeper.

SIM card

The intelligent emergency call system operates via mobile radio through the SIM card installed in the vehicle. The SIM card is permanently logged into the mobile phone network so a connection setup can be established quickly. The data is

sent to the vehicle manufacturer in the event of an emergency.

Improving quality

The vehicle manufacturer also uses the data sent as part of an emergency call to improve product and service quality.

Position determination

Only the provider of the mobile phone network is able to determine the position of the vehicle based on mobile phone mast locations. The network operator is not able to link the vehicle identification number to the phone number of the installed SIM card. Only the vehicle manufacturer is able to link the vehicle identification number to the phone number of the installed SIM card.

Log data for emergency calls

The log data for emergency calls is saved in a vehicle memory. The oldest log data is regularly deleted. The log data includes information on when and where an emergency call was placed, for example in the event of an accident.

In exceptional cases, the log data can be read out from the vehicle memory. The log data is usually read out only if a court order has been issued and is only possible when the relevant devices are connected directly to the vehicle.

Automatic emergency call

The system has been designed so that an emergency call is triggered automatically when an accident of a certain severity occurs and is detected by the sensors in the vehicle.

Sent information

If an emergency call is made by the intelligent emergency call system, the same information is conveyed to the appointed emergency call centre as is normally conveyed to the public rescue coordination centre by the eCall statutory emergency call system.

Furthermore, the intelligent emergency call system also conveys the following additional information to an emergency call centre appointed by the vehicle manufacturer and, where applicable, to the public rescue coordination centre:

- ▶ Accident data, for example the direction of the collision as detected by the vehicle sensors in order to assist the rescue services in their deployment plans.
- ▶ Contact data, for example the phone number of the installed SIM card and the driver's phone number, if available, so that those involved in the accident can be contacted quickly if necessary.

Data storage

The data relating to a placed emergency call is saved in the vehicle. The data contains information about the emergency call, for example the place and time it was made.

The emergency call centre saves audio recordings of the emergency call.

Audio recordings of the customer are saved for 24 hours, in case details of the emergency call need to be analysed. After that, the audio recordings are deleted. Audio recordings of the emergency call centre employee are saved for 24 hours for quality assurance purposes.

Disclosure of personal data

The data obtained in the context of an intelligent emergency call is only used to process the emergency call. If legally obliged to do so, the vehicle manufacturer will disclose the data it has processed and, where applicable, still has saved.

Statutory emergency call system

The owner of a vehicle equipped with an intelligent emergency call system and the eCall statutory emergency call system is entitled to use the on-board eCall system instead of the intelligent emergency call function.

To request deactivation, please contact a Service Partner of the manufacturer or another qualified Service Partner or a specialist workshop.

The eCall statutory emergency call system is always on standby in addition to the intelligent emergency call system. The eCall statutory emergency call system takes over the emergency call function if the intelligent emergency call system is not operational for technical reasons, for example if the emergency call centre appointed by the vehicle manufacturer cannot be reached.

The eCall statutory emergency call system uses the infrastructure of the 112 public emergency call number.

The system can be configured so that emergency calls are always made via the eCall statutory emergency call system and not via the intelligent emergency call system. Have the setting configured by a Service Partner of the manufacturer or another qualified Service Partner or a specialist workshop.

Vehicle identification number

General

Depending on the national-market equipment, the vehicle identification number is located at different positions in the vehicle. This chapter describes all the positions that are possible for the model range.

Under the bonnet



The vehicle identification number is engraved under the bonnet, on the right-hand side of vehicle.

Type plate on right-hand side



The vehicle identification number is on the type plate on the right-hand side of vehicle.

Type plate on left-hand side



The vehicle identification number is on the type plate on the left-hand side of vehicle.

Windscreen



The vehicle identification number is additionally located behind the windscreen.

iDrive

It is also possible to display the vehicle identification number via iDrive.

1. "MENU"
2. "All apps"
3. "Device manager"
4. "Settings"
5. "Vehicle ID (VIN):"

Safety of the high-voltage system

Vehicle equipment

This chapter describes equipment, systems and functions which are offered or will be offered on a model-specific basis, even if they are not included in the vehicle in question.

For further information:

Vehicle equipment, see page 7.

Working on the vehicle

General

Changes and work on the vehicle, for example the retrofitting of accessories, must only be carried out by a Service Partner of the manufacturer or another qualified Service Partner or a specialist workshop that operates to BMW specifications with suitably trained personnel.

Safety note

WARNING

An electric shock can occur if the work is not carried out correctly, in particular maintenance and repair of the high-voltage system. There is a danger of injury, fire or danger to life. Only have work on the vehicle, particularly maintenance, repair and modifications, carried out by a Service Partner of the manufacturer or another qualified Service Partner or a specialist workshop.

Contact with water

The high-voltage system is generally safe also in the following example situations:

- ▶ When there is water in the footwell, for example after a rain shower with the window open.
- ▶ The vehicle is in water up to the allowed height.
- ▶ If liquid spills in the luggage compartment.

Monitoring the high-voltage battery

Principle

The temperature in the high-voltage battery is monitored.

An unusually high temperature in the high-voltage battery is indicated.

Safety note

WARNING

An unusually high temperature of the high-voltage battery can cause a formation of gas and smoke. There is a danger of injury or danger to life. In case of noticeable unusual odour or smoke formation, refer to the notes for actions in the event of a message.

High temperature message

While the vehicle is moving

A Check Control message is shown.

During and shortly after the charging process

Depending on the national-market version: the vehicle sounds the horn and, if applicable, the vehicle lights are flashing.

Actions in the event of a message

While the vehicle is moving

1. Stop immediately.
2. Park the vehicle safely.
3. Exit the vehicle.
4. Establish and keep a sufficient distance to the vehicle.
5. Alert emergency personnel.

During and shortly after the charging process

1. If necessary, exit the vehicle.
2. Establish and keep a sufficient distance to the vehicle.
3. Alert emergency personnel.

Automatic deactivation

In the event of an accident the high-voltage system is shut down automatically so as not to endanger vehicle occupants and other road users.

For further information:

Conduct after an accident, see page [369](#).

Owner's Handbook media

Vehicle equipment

This chapter describes equipment, systems and functions which are offered or will be offered on a model-specific basis, even if they are not included in the vehicle in question.

For further information:

Vehicle equipment, see page 7.

General

Media overview

Content from the Owner's Handbook can be accessed in different formats. The Owner's Handbook is available in the following formats:

- ▶ Printed Owner's Handbook.
- ▶ Integrated Owner's Handbook in the vehicle.

Validity of Owner's Handbook

Vehicle production

At the time of production in the factory, the printed Owner's Handbook provides up-to-date information. Updates following the copy deadline can result in differences between the printed Owner's Handbook and the integrated Owner's Handbook in the vehicle.

Notes on updates can be found in the appendix of the printed Owner's Handbook for the vehicle.

After a software update in the vehicle

After a vehicle software update, for example, via Remote Software Upgrade, the Integrated Owner's Handbook for the vehicle will contain the latest information.

Printed Owner's Handbook

Principle

The printed Owner's Handbook shows all standard equipment, national-market equipment and optional equipment which is offered or will be offered on a model-specific basis.

General

The Owner's Handbook for Navigation, Entertainment and Communication is available as a printed book from Service.

Supplementary Owner's Handbooks

Please also follow the Supplementary Owner's Handbooks which are provided along with the on-board literature as required.

Integrated Owner's Handbook in the vehicle

Principle

The Integrated Owner's Handbook shows all standard equipment, national-market equipment and optional equipment which is offered or will be offered on a model-specific basis. The integrated Owner's Handbook can be shown on the control display.

Selecting the Owner's Handbook

1. "MENU"
2. "All apps"
3. "Owner's Handbook"
4. Select the required method of accessing the contents.

Scrolling within the Owner's Handbook

Swipe up or down until the next or previous contents are displayed.

Context-sensitive help

General

The integrated Owner's Handbook can be called up from any menu. Depending on the selected function, the associated description or main menu of the integrated Owner's Handbook is displayed.

Selecting context-sensitive help from a menu

1. Press and hold the relevant menu item.
2. "Help"

Selecting context-sensitive help from a Check Control message

To switch directly from the Check Control message on the control display:

"Owner's Handbook"

Getting in

Opening and closing

Vehicle key



Buttons on the vehicle key.

Icon	Meaning
	Unlock.
	Lock.
	Open/close the luggage compartment.
	Function adjustable: Home lights. Pre-conditioning.

Access to vehicle interior

Unlocking with the vehicle key

 Press the button on the vehicle key.

Depending on the settings, this will unlock the driver's door only, or all vehicle access points.

If only the driver's door is unlocked, press the button on the vehicle key again to unlock the other vehicle access points.

Locking with the vehicle key

1. Close the driver's door.
2.  Press the button on the vehicle key. All vehicle access points are locked.

Unlocking on the outside door handle

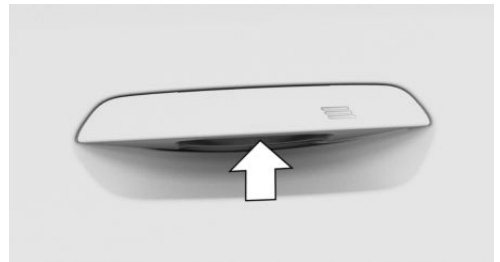

If you are carrying the vehicle key on your person, reach into the handle recess.

Locking on the outside door handle

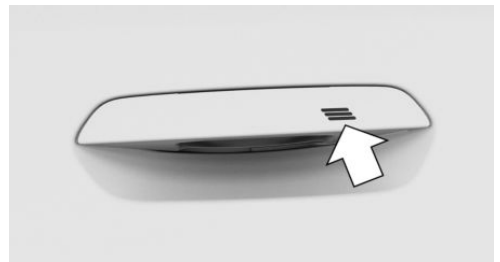

If you are carrying the remote control on your person, touch the grooved surface on the outside door handle of a closed vehicle door with your finger for approx. 1 second without reaching into the handle recess.

Central locking buttons

Overview



Central locking buttons.

Locking the vehicle



Press the button with the front doors closed.

Unlocking the vehicle



Press the button.

Access to the luggage compartment

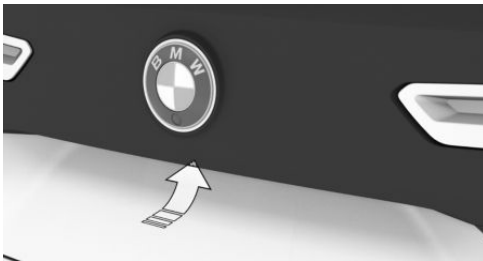

Opening the luggage compartment



- ▷ Unlock the vehicle and then press the button on the outer side of the luggage compartment.
- ▷  Press the button on the vehicle key for approximately 1 second.
The doors are unlocked if applicable.

Closing the luggage compartment



- ▷  Press the button on the inside of the luggage compartment.
- ▷  Hold down the button on the vehicle key until luggage compartment is closed.

Touchless opening and closing of the luggage compartment

Touchless opening and closing of the luggage compartment is possible when carrying the vehicle key on your person.

1. Stand in the centre behind the vehicle, approximately an arm's length away from the rear of the vehicle.
2. Kick your foot as far as possible underneath the vehicle and immediately pull it back. Your leg must move across the ranges of both sensors.



Displays, operating elements

Around the steering wheel

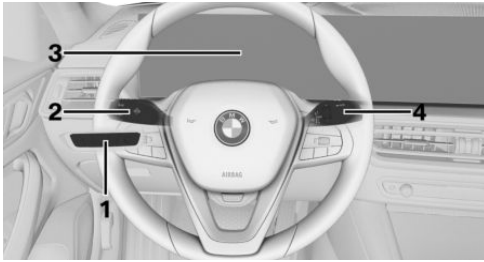

- 1 Light switch element
- 2 Turn indicator, high-beam headlight
- 3 Instrument cluster
- 4 Windscreen wipers

Indicator and warning lights

Indicator and warning lights can illuminate in a variety of combinations and colours.

When switching on drive-ready state, the functionality of some lights is checked and they illuminate briefly.

Driver's door

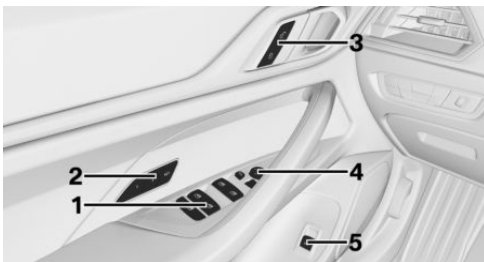

- 1 Electric windows
- 2 Seats, comfort functions
- 3 Central locking system
- 4 Exterior mirrors
- 5 Opening/closing the luggage compartment

Switch cluster

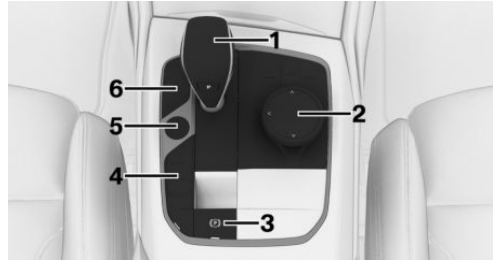

- 1 Selector lever
- 2 Controller
- 3 Parking brake, Automatic Hold
- 4 Driving Experience Control
- 5 Start/Stop button
- 6 Park assistance systems

iDrive

Principle

iDrive is the operating concept of the infotainment system and includes a large number of functions.

Buttons on the Controller

Button	Function
HOME	To go to the main menu.
MEDIA	To go to the Media/Radio menu.
TEL	To go to the Telephone menu.
MAP	To go to the navigation map.
NAV	To go to the destination entry menu of the navigation system.

Button	Function
	Go to previous display area.
	To go to the Options menu.



Voice input

Activating voice input

-  Press the button on the steering wheel.
- Say the command.

Cancelling voice input

-  Press the button on the steering wheel or say ›Cancel.

Adjustment and operation

Seats, mirrors and steering wheel

Manually adjustable seats

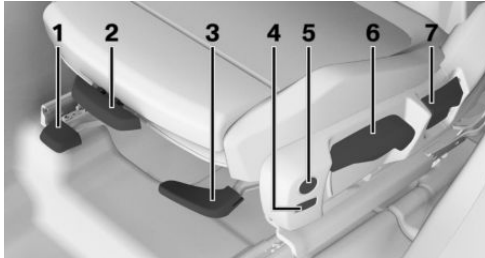

- 1 Longitudinal direction
- 2 Thigh support
- 3 Seat angle
- 4 Backrest width
- 5 Lumbar support
- 6 Height
- 7 Backrest angle

Electrically adjustable seats

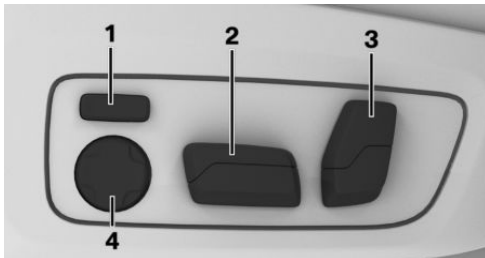

- 1 Backrest width
- 2 Height/longitudinal direction/seat angle
- 3 Head restraint/backrest angle
- 4 Lumbar support

Adjusting the head restraint

Adjusting the height: manual head restraints

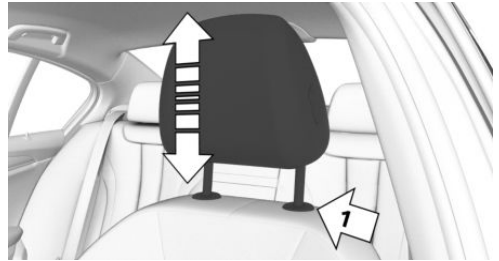

- ▷ Down: press the button, arrow 1, and slide the head restraint downwards.
- ▷ Up: push the head restraint upwards.

After adjusting the height, make sure that the head restraint engages correctly.

Adjusting the height: electric head restraints

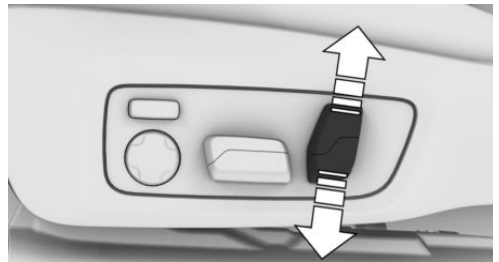

Press the switch up or down.

Adjusting the distance



- ▷ Back: press the button and push back the head restraint.
 - ▷ Forward: pull the head restraint forwards.
- After adjusting the distance, make sure that the head restraint engages correctly.

Adjusting the exterior mirrors



Icon	Meaning
	Folding in and out.
	Adjusting.
	Select mirror, automatic parking function.



Folding in and out.



Adjusting.



Select mirror, automatic parking function.

Adjusting the steering wheel

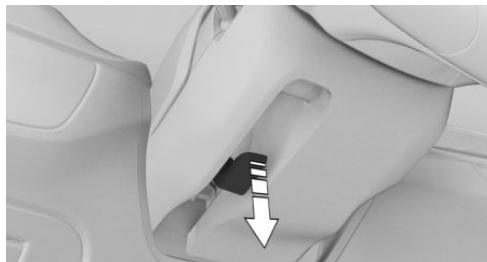

1. Fold the lever down fully.
2. Grip the steering wheel with both hands and adjust it in the longitudinal direction and height of the seat position.
3. Fold the lever back up.

Memory function

Principle

The memory function enables the following settings to be stored and retrieved when required:

- ▷ Seat position.
- ▷ Exterior mirror position.
- ▷ Steering wheel position.
- ▷ Depending on the equipment: height of the Head-up display.

Overview



The memory buttons are on the front doors.

Storing settings

1. Set the desired position.
2.  Press the button. The LED is illuminated.
3. Press the desired button 1 or 2 while the LED is illuminated. A signal sounds.

Go to Settings





Press the desired button 1 or 2.

Infotainment

Entertainment

Buttons and functions

Depending on the country and equipment specification, the following buttons are installed in the centre console or instrument panel.

Button	Function
	Turn the knob to set the volume. Press the knob to switch off the sound output. Pressing again restores the previous volume.
	Changing the entertainment source.
	Press once: to change the station/music track.
	Press and hold: to fast forward/rewind the music track.

Navigation destination entry

1. "NAV"
2. "Destination input"

3. To enter a new destination or start route guidance, tap on the search field or select an entry from the search history.
4. Enter at least two characters.
If necessary, start the search for point of interest categories from the Points of Interest menu.
If necessary, accept the suggested search term.
5. A list of results is displayed.
6. Select the desired entry.

Using the mobile phone

General

Once the mobile phone has been connected in the vehicle, it can be operated using iDrive and the buttons on the steering wheel.

Activate Bluetooth® on the mobile phone.

Connecting via Bluetooth®

1. "MENU"
2. "All apps"
3. "Device manager"
4. "Connect new device"
Mobile phones in range are displayed on the control display.
5. Select the required mobile phone
6. Compare the control number displayed on the control display with the control number in the display of the mobile phone and confirm that they match.
7. If necessary, select the connection mode: "Use Bluetooth"

The device is connected and displayed in the device list.

Accepting a call

Depending on the equipment, incoming calls can be accepted in different ways.

- ▶ Via iDrive:

 "Accept"



- ▷ Press the relevant button on the steering wheel.
- ▷ Use the knurled wheel on the steering wheel to select from the list in the instrument cluster: "Accept"

Dialling a number

1. "TEL"
2. "More"
3. "Dial number"
4. Enter the numbers.
5.  Select the icon. The call is made using the mobile phone to which the telephone function is assigned.

Apple CarPlay® preparation

Principle

CarPlay enables selected functions of a compatible Apple iPhone to be operated by Siri voice control and iDrive.

Operating requirements

- ▷ Compatible iPhone, iPhone 5 or later with iOS 7.1 or later.
- ▷ Appropriate mobile radio contract.
- ▷ The setting for mobile data may need to be activated on the iPhone.
- ▷ Bluetooth, WLAN and Siri voice control are activated on the iPhone.
- ▷ WLAN and Bluetooth are activated in the vehicle.

Pairing the iPhone with CarPlay

1. "MENU"
2. "All apps"
3. "Device manager"
4. "Connect new device"

Mobile phones in range are displayed on the control display.

5. Select the desired mobile phone on the control display or the Bluetooth® name of the vehicle on the display of the mobile phone.
6. Compare the control number displayed on the control display with the control number in the display of the mobile phone and confirm that they match.
7. Select CarPlay as the connection mode: "Use Apple CarPlay"
8. Confirm the connection mode on the display of the smartphone.

The iPhone is connected to the vehicle and displayed in the device list.

Android Auto® preparation

Principle

Android Auto enables selected functions of a compatible smartphone to be operated by Google Assistant voice control and iDrive.

Operating requirements

- ▷ Compatible Android smartphone: Samsung or Google smartphone with Android 10 or an Android smartphone with Android 11, regardless of the manufacturer.
- ▷ Appropriate mobile radio contract.
- ▷ Bluetooth and WLAN are activated on the smartphone.
- ▷ The setting for mobile data may need to be activated on the smartphone.
- ▷ WLAN and Bluetooth are activated in the vehicle.
- ▷ The smartphone must support a 5 Ghz WiFi connection.

Pairing the smartphone with Android Auto

1. "MENU"
2. "All apps"
3. "Device manager"
4. "Connect new device"
Mobile phones in range are displayed on the control display.
5. Select the desired mobile phone on the control display or the Bluetooth® name of the vehicle on the display of the mobile phone.
6. Compare the control number displayed on the control display with the control number in the display of the mobile phone and confirm that they match.
7. Select Android Auto as the connection mode:
"Use Android Auto"
8. Confirm the connection mode on the display of the smartphone.

The smartphone is connected to the vehicle and displayed in the device list.

On the move

Driving

Drive-ready state

General

An active drive-ready state is the same as the engine running in conventional vehicles.

Switching on drive-ready state



1. Close the driver's door.
2. Press the brake.
3. Press the Start/Stop button.

An acoustic signal sounds. Drive-ready state is switched on.

Display in the instrument cluster

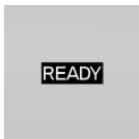

The READY indicator shows that the vehicle is ready to drive.

Switching off drive-ready state

After stopping:

1. Press the brake and engage selector lever position P.
 2. Apply the parking brake.
 3. Press the Start/Stop button.
- The READY display is no longer illuminated and an acoustic signal is heard.

Drive-ready state in detail

Operating requirements

Driving is possible if the following conditions are met:

- ▶ The high-voltage battery is sufficiently charged.
- ▶ The driver's door is closed.
- ▶ Charging cable is disconnected.

Driving

1. Switch on drive-ready state.
2. Press the brake and engage selector lever position D, B or R.
3. Release the parking brake.
4. Drive away by applying the accelerator pedal.

Engaging selector lever position D, N, R

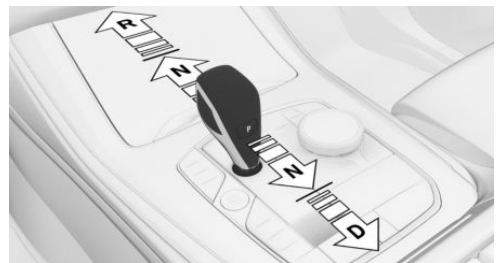

- ▶ D drive position.
- ▶ N Neutral.
- ▶ R reverse gear.

Apply the brake until ready to drive off, otherwise the vehicle will move when drive position or reverse gear is selected.

With the driver's seat belt fastened, briefly tap the selector lever in the desired direction, beyond a resistance point if required. The selector lever returns to the centre position in each case.

Before shifting out of P, disconnect the charging cable from the vehicle, otherwise the gearshift request is not performed.

Only engage selector lever position R when the vehicle is stationary.

A selector lever lock prevents inadvertently shifting to selector lever position R or an inadvertent change from selector lever position P.

Cancelling the selector lever lock

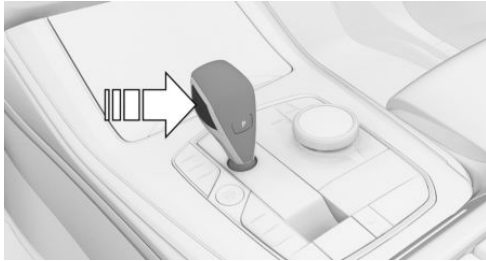

Press the button.

Engaging selector lever position P

Only engage selector lever position P when the vehicle is stationary.



Press button P.

Engaging selector lever position B

Selector lever position B is the drive position with the highest energy recovery.

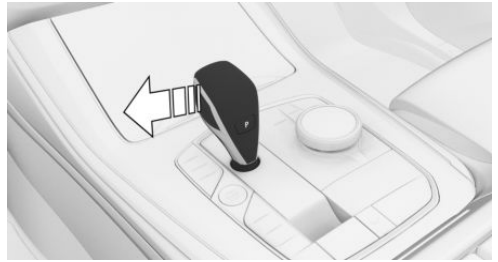

Press the selector lever out of selector lever position D to the left.

Parking brake

Applying the parking brake



Pull the switch.

The LED on the switch and the indicator light in the instrument cluster are illuminated.

Release the parking brake



With drive-ready state switched on:

Press the switch with the brake applied or the selector lever in position P.

The LED and the indicator light are no longer illuminated.

The parking brake is released.

Parking

Make sure the parking brake is engaged.

Turn indicators, high-beam headlights, headlight flasher

Turn indicators

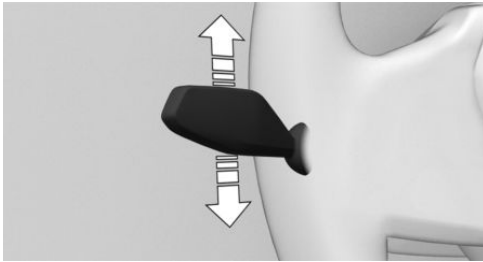

- ▶ Flashing: press the lever past the resistance point.
- ▶ One-touch signalling: lightly tap the lever up or down.
- ▶ To indicate a turn briefly: press the lever as far as the resistance point and hold it there for as long as you wish to indicate a turn.

High-beam headlights, headlight flasher



Push the lever forwards or pull it back.

- ▶ High-beam headlights on, arrow 1.
The high-beam headlights are illuminated when the low-beam headlight is switched on.
- ▶ High-beam headlights off/headlight flasher, arrow 2.

Lights and lighting

Buttons in the vehicle

Icon	Function
	Rear fog light.
	Lights off. Daytime driving lights.
	Side lights.
	Automatic driving lights control. Adaptive lighting functions.
	Low-beam headlight.
	Instrument lighting.
	Parking light, right.
	Parking light, left.

Wiper system

Switching on the wiper system

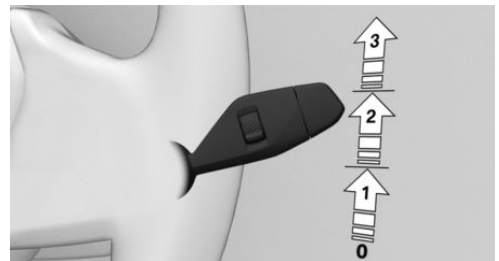

Press the lever upwards to the desired position.

- ▷ Rest position of the wipers: position 0.
- ▷ Rain sensor: position 1.
- ▷ Normal wiper speed: position 2.
- ▷ Fast wiper speed: position 3.

Switching off the wiper system and flick wiping

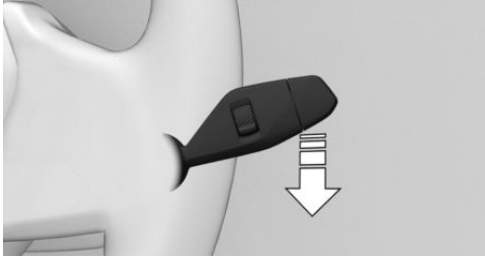

Press the lever down.

- ▷ To switch off: press lever downwards until position 0 is reached.
 - ▷ To flick wipe: press the lever downwards from position 0.
- The lever returns to position 0 when released.

Activating/deactivating the rain sensor

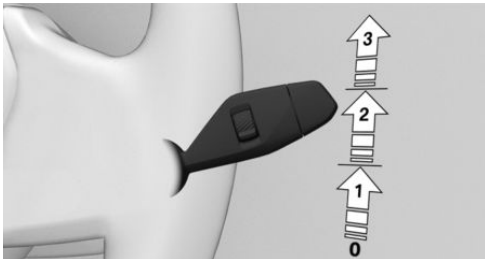

To activate: press the lever upwards once from position 0, arrow 1.

To deactivate: press the lever back to position 0.

Setting the sensitivity of the rain sensor

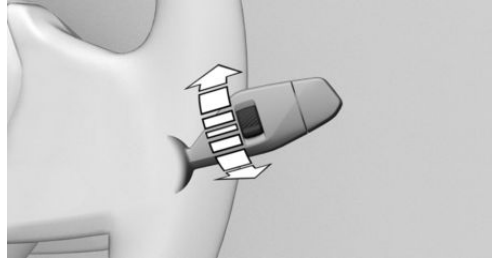

Turn the knurled wheel on the wiper lever.

Cleaning the windscreen

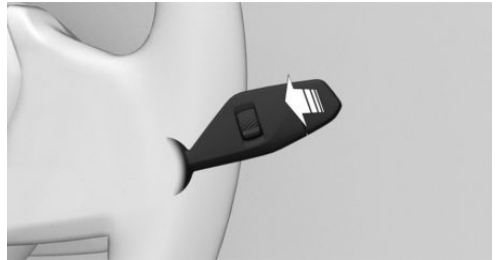









Pull the lever.

Air conditioning

Air conditioning functions

Functions in the air conditioning menu



Icon	Function
AUTO	AUTO programme.
22.0°C	Temperature.
MAX A/C	Maximum cooling.

Icon	Function
	Air recirculation function.
	Automatic air recirculation control.
	Fresh air.
	Amount of air.
	Air distribution.
	SYNC programme.
	Seat heating.
	Active seat ventilation.

The functions can also be operated via voice, for example, Temperature.

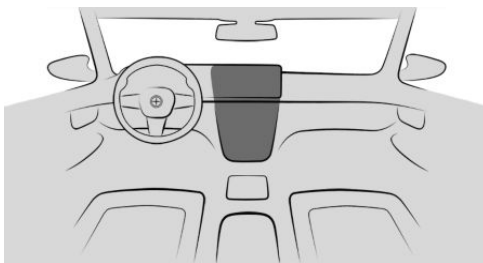



Buttons, integrated automatic heating/air conditioning system

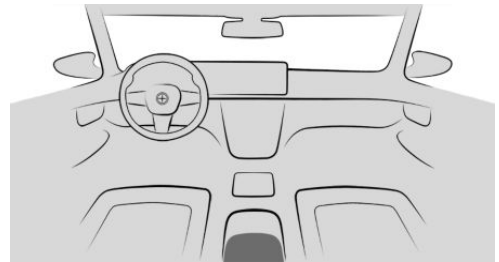

Icon	Function
	Defrost function.
	Rear window heating.

Buttons, automatic rear air-conditioning system



Icon	Function
	AUTO programme.
	Temperature.
	Air distribution.
	Seat heating, see page 122.
	To switch off.

Pit stop

Charging vehicle

To charge the vehicle, use a mode 2 charging cable, a mode 3 charging cable or a fixed cable of a charging station depending on the national-market version.

The charging cable may be located in the luggage compartment, for example under the luggage compartment floor or in a bag.

Before disconnecting and connecting a charging cable, clean the area between the charging socket flap and charging socket outlet and the charging cable plug if necessary, for example remove any snow.

Unlock the charging cable before disconnecting it, if necessary.

The charging status is indicated on the indicator light on the charging socket.

Keep the charging socket flap and, if applicable, the charging socket cover, closed when the charging socket is not in use.

Wheels and tyres

Tyre inflation pressure information



The tyre inflation pressure information can be found on the tyre pressure label on the body pillar of the driver's door.

After adjusting the tyre inflation pressure

For the flat tyre monitor RPA:

Reinitialise the flat tyre monitor RPA.

For the Tyre Pressure Monitor:

The corrected tyre inflation pressures are applied automatically. Make sure that the tyre settings are correct.

For tyres that are not listed in the tyre inflation pressure information on the control display, reset the Tyre Pressure Monitor.

Checking the tyre inflation pressure

Check regularly and adjust as necessary:

- ▶ At least twice a month.
- ▶ Before a long journey.

How to get assistance

Hazard warning lights

Button in the vehicle

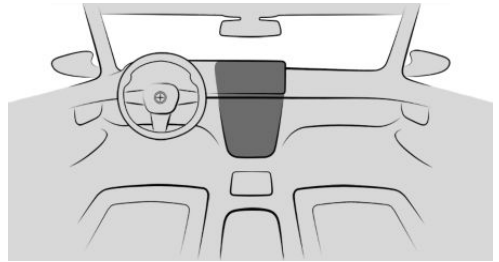

Hazard warning lights button

Help in case of a breakdown

BMW Emergency Service

1. "MENU"
2. "All apps"
3. "Assistance"
4. If necessary, select the entry for BMW Road-side Assistance.

A voice contact is established.

ConnectedDrive

Concierge Service

The Concierge Service provides information about hotels, restaurants etc. and can send an SMS with the required information to the vehicle.

Addresses can also be sent directly to the navigation system.

1. "MENU"
2. "All apps"
3. "Assistance"
4. Select the entry for the Concierge Service if applicable.

A voice contact to the Concierge Service is established.

Teleservices

Teleservices are services that help to keep the vehicle mobile.

Teleservices may include the following services:

- ▶ BMW Roadside Assistance.
- ▶ BMW Accident Assistance.
- ▶ Teleservice Call.
- ▶ Your Service Partner.

Vehicle cockpit

Vehicle equipment

This chapter describes equipment, systems and functions which are offered or will be offered on

a model-specific basis, even if they are not included in the vehicle in question.

For further information:

Vehicle equipment, see page 7.

Around the steering wheel

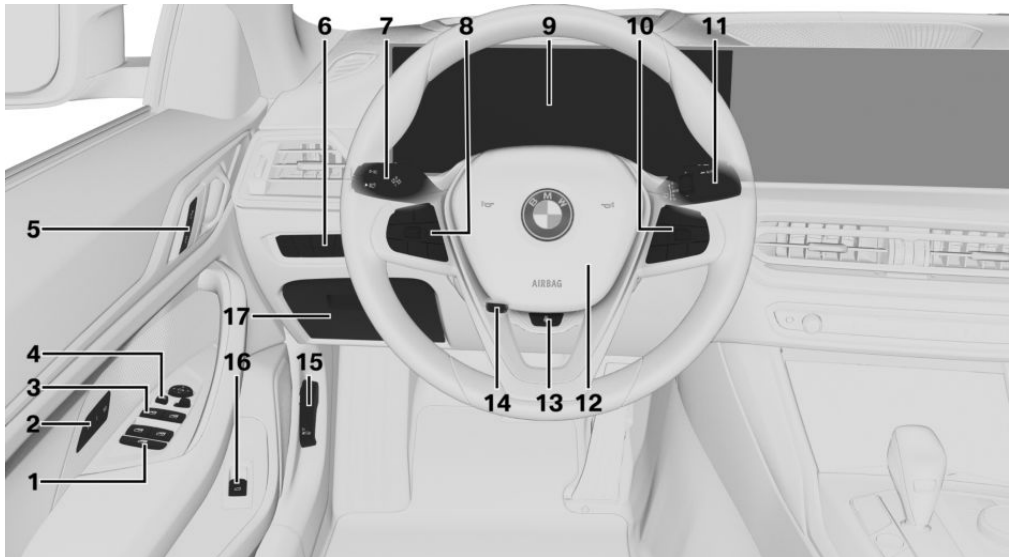

1 Safety switch 105

2 Seat comfort functions



Memory function 121



3 Electric windows, individual 103

4 Exterior mirror operation 119

5 Central locking system 99



To unlock



To lock

6 Lights



Rear fog light 183



Light switch 177



Lights off

Daytime driving lights 180

Side lights [178](#)Automatic driving lights control [177](#)Adaptive lighting functions [180](#)High-beam Assistant [182](#)Low-beam headlight [178](#)Instrument lighting [184](#)Right parking light [178](#)Left parking light [178](#)**7** Steering column lever, leftTurn indicator [148](#)High-beam headlight, headlight flasher [149](#)High-beam Assistant [182](#)Trip data [171](#)**8** Buttons on steering wheel, leftManual Speed Limiter [224](#)Depending on the equipment:
Cruise Control on/off [226](#)Depending on the equipment:
Active Cruise Control on/off [229](#)With Steering and Lane Control Assistant [241](#):

Cruise Control, distance control and lane tracking on/off

Cruise Control: to store a speed
Speed Limit Assist: to accept the suggested speed [237](#)

To interrupt or resume Cruise Control



Active Cruise Control: to increase the distance



Active Cruise Control: to reduce the distance



Cruise Control rocker switch

9 Instrument cluster [153](#)**10** Buttons on steering wheel, rightDisplaying the menu bar in the instrument cluster [153](#)Volume, see Owner's Handbook for Navigation, Entertainment, Communication [6](#)Voice control system [61](#)Selecting the menu contents in the instrument cluster [153](#)To change the station/music track, see the Owner's Handbook for Navigation, Entertainment, Communication [6](#)



Telephone, see Owner's Handbook for Navigation, Entertainment, Communication [6](#)



Knurled wheel for selecting configuration menus for instrument cluster and head-up display [153](#)

Operating the infotainment selection lists in the instrument cluster [170](#)

11 Steering column lever, right



Windscreen wipers [149](#)



Rain sensor [150](#)



To clean the windscreen [151](#)



12 Horn, entire area



13 Steering wheel heating [121](#)

14 To adjust the steering wheel [121](#)

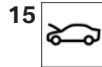

15 To unlock the bonnet [352](#)

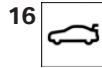

16 Opening and closing luggage compartment [91](#)

17 Glove compartment [288](#)

Around the centre console

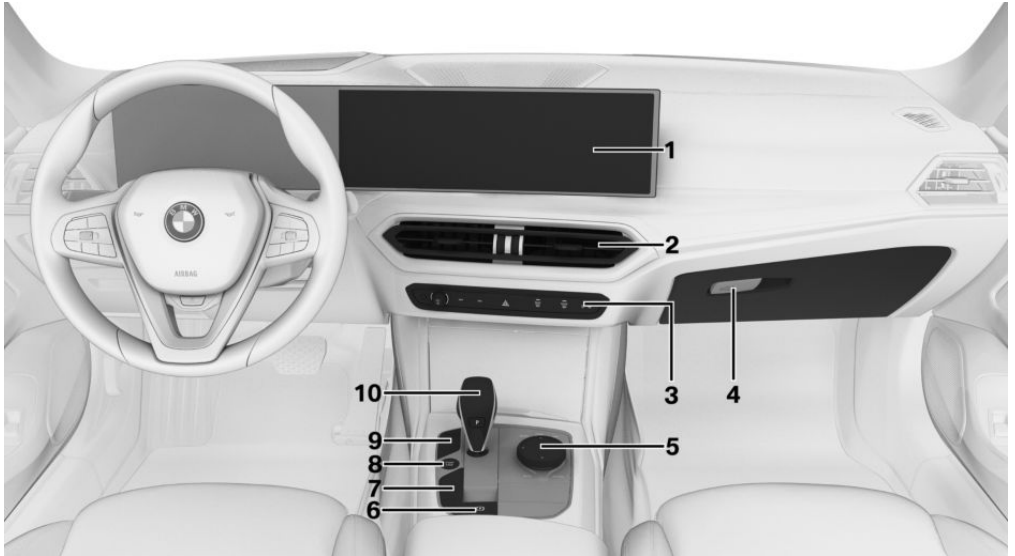

1 Control display [57](#)

2 Ventilation [279](#)

3  Hazard warning lights [364](#)

Climate control [273](#)

 Defrost function [278](#)

 Rear window heating [279](#)

Radio/multimedia, see Owner's Handbook for Navigation, Entertainment, Communication [6](#)

 Adjusting the volume

 Station/track forward

 Station/track back

4 Button for glove compartment [288](#)

5 Controller with buttons [58](#)

6  Automatic Hold [147](#)



6  Parking brake [145](#)

7  Driving Experience Control [144](#)
SPORT drive mode

 COMFORT drive mode





 ECO PRO drive mode

8  Turning drive-ready state on/off [137](#)

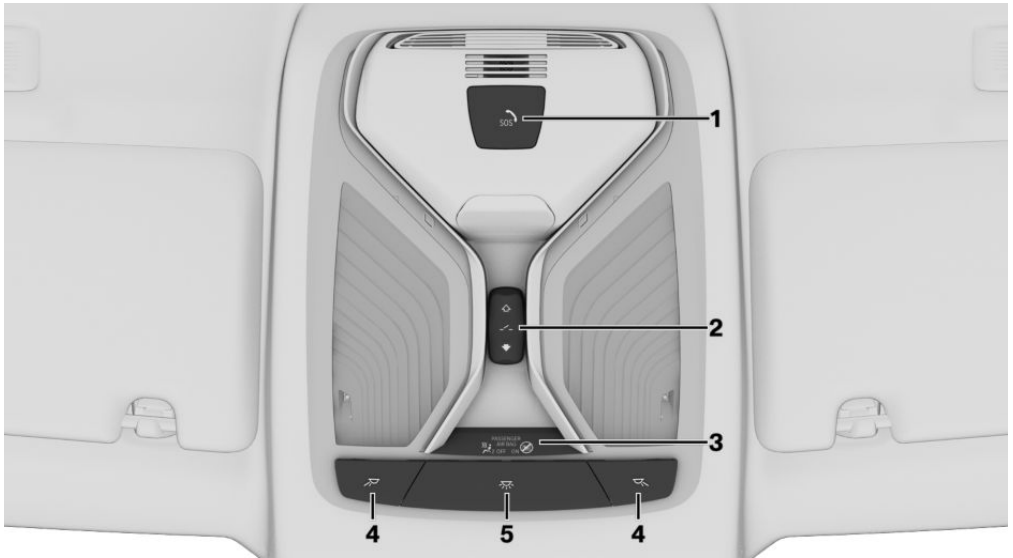
- 9  Parking assistance systems [251](#) 10 Selector lever [137](#)
-  Panorama View [257](#)
-  Dynamic Stability Control [220](#)

Around the headliner



- 1  Emergency call, SOS [366](#) 4  Reading lights [185](#)
- 2  To operate the electric glass sun-roof [106](#) 5  Interior lights [184](#)
- 3  Front passenger airbag indicator light [189](#)

Sensors in the vehicle

Vehicle equipment

This chapter describes equipment, systems and functions which are offered or will be offered on a model-specific basis, even if they are not included in the vehicle in question.

For further information:

Vehicle equipment, see page 7.

Overview

Depending on the equipment, the following cameras and sensors are installed in the vehicle:

- ▶ Front camera.
- ▶ Camera behind the windscreen.
- ▶ Exterior mirror cameras.
- ▶ Reversing Assist Camera.
- ▶ Front radar sensor.
- ▶ Side radar sensors, front.
- ▶ Side radar sensors, rear.
- ▶ Ultrasonic sensors in the front/rear bumpers.
- ▶ Side ultrasonic sensors.

Cameras

Front camera

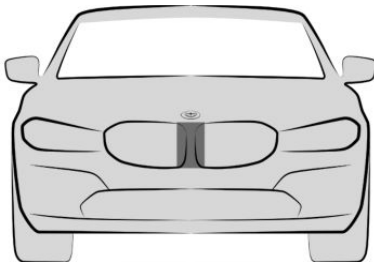

The front camera is in the area shown.

Camera behind the windscreen

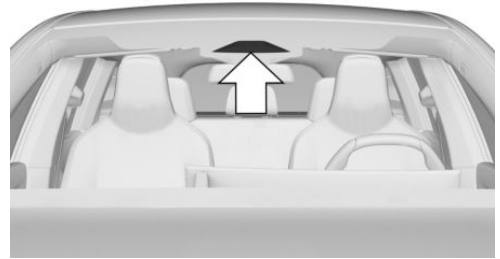

The camera is located near the interior mirror.

Exterior mirror cameras

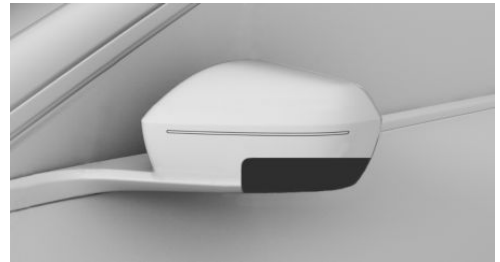

A camera is located under each exterior mirror housing.

Reversing Assist Camera

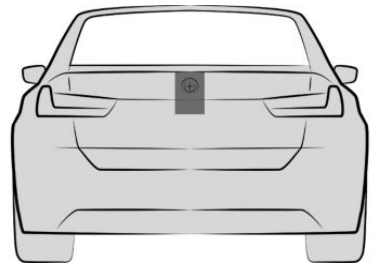

The camera is located in the badge at the rear end.

Functional requirement of the cameras

The areas of the cameras are clean and clear.

For further information:

- ▷ Washing the vehicle, see page 373.
- ▷ Vehicle care, see page 374.

System limits of the cameras

The function of the cameras can be restricted or may indicate something wrong, for example in the following situations:

- ▷ In thick fog, wet conditions or snow.
- ▷ On steep crests or dips or on tight bends.
- ▷ When the camera field of view is covered, for example by a fogged up windscreen or labels.
- ▷ If the camera lens is dirty or damaged.
- ▷ With the exterior mirrors folded in.
- ▷ With open doors or open luggage compartment.
- ▷ In the case of bright oncoming light or strong reflections, for example if the sun is low in the sky.
- ▷ In the dark.
- ▷ The camera has overheated due to excessive temperatures and temporarily turned off.
- ▷ During the camera calibration process immediately after vehicle delivery.

A Check Control message may be displayed if the system limits are reached.

Radar sensors

Front radar sensor

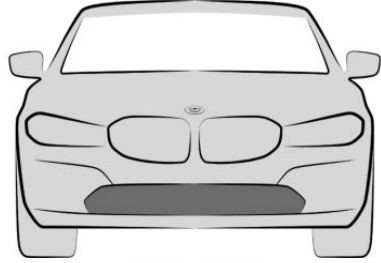

The radar sensor is located in the area shown.

Side radar sensors, front

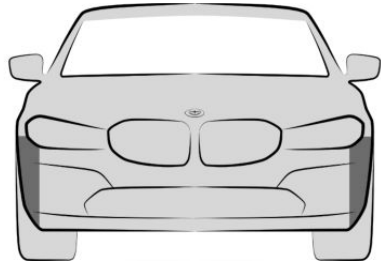

The radar sensors are located in the areas shown.

Side radar sensors, rear

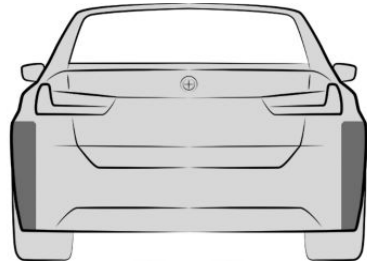

The radar sensors are located in the areas shown.

Functional requirement of the radar sensors

The areas of the radar sensors are clean and clear.

For further information:

- ▶ Washing the vehicle, see page 373.
- ▶ Vehicle care, see page 374.

System limits of the radar sensors

The function of the radar sensors can be restricted or not available, for example in the following situations:

- ▶ If the sensors are contaminated.
- ▶ In case of iced up sensors.
- ▶ If the sensors are obscured, for example by stickers, foils or a number plate holder.
- ▶ If the sensors are misaligned, for example due to parking damage.
- ▶ If the radiation range of the sensors is covered, for example by protruding loads.
- ▶ When the field of view of the sensors is covered, for example by garage walls, hedges, snow hills, vehicles or trailers.
- ▶ After work performed incorrectly on the vehicle paintwork near to the sensors.
- ▶ At steep crests or hollows of hills.

A Check Control message may be displayed if the system limits are reached.

Ultrasonic sensors

Ultrasonic sensors, front

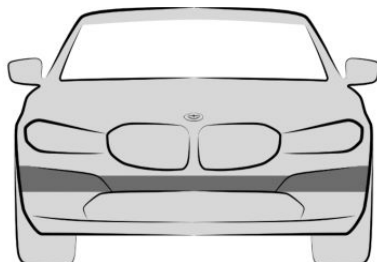

The ultrasonic sensors of the parking assistance systems are located in the area shown.

Ultrasonic sensors, rear

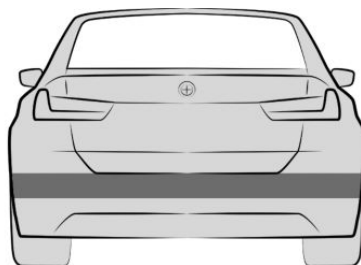

The ultrasonic sensors of the parking assistance systems are located in the area shown.

Side ultrasonic sensors

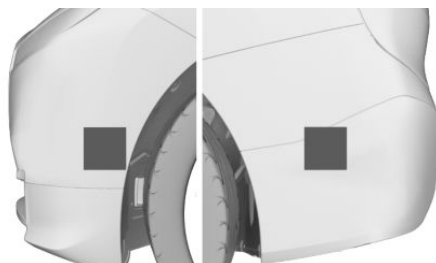

The ultrasonic sensors of the parking assistance systems are located on the sides of the vehicle in the area shown.

Functional requirement of the ultrasonic sensors

The areas of the ultrasonic sensors are clean and clear.

For further information:

- ▶ Washing the vehicle, see page 373.
- ▶ Vehicle care, see page 374.

System limits of the ultrasonic sensors

The physical limits of ultrasound measurement may be reached when detecting objects in situations involving the following, for example:

- ▶ If the sensors are contaminated.
- ▶ If the sensors are obscured, for example by stickers.
- ▶ If the sensors are misaligned, for example due to parking damage.
- ▶ After work performed incorrectly on the vehicle paintwork near to the sensors.
- ▶ Small children and animals.
- ▶ Persons wearing certain types of clothing, for example a coat.
- ▶ Obstacles and people at the edge of the driving lane.
- ▶ If there is external interference with the ultrasonic sound, for example by passing vehicles, loud machines or other ultrasonic sources.
- ▶ Certain weather conditions; for example, high humidity, wet conditions, snowfall, cold, extreme heat or strong wind.
- ▶ Trailer drawbars and tow hitches of other vehicles.
- ▶ Thin or wedge-shaped objects.
- ▶ Moving objects.
- ▶ Higher protruding objects, for example projecting walls.
- ▶ Objects with corners, edges and smooth surfaces.

- ▶ Objects with fine surfaces or structures, for example fences.
- ▶ Objects with porous surfaces.
- ▶ Small and low objects such as boxes.
- ▶ Low objects already displayed, for example, kerbs, can be outside of the detection ranges of the sensors.
- ▶ Soft obstacles or obstacles covered in foam.
- ▶ Plants or shrubs.
- ▶ In washing bays and car washes.
- ▶ On uneven surfaces, for example speed bumps.
- ▶ In the presence of dense exhaust fumes.
- ▶ The ultrasonic sensors do not take into account loads projecting beyond the outline of the vehicle.
- ▶ If the cover of the trailer tow hitch is incorrectly seated.

A Check Control message may be displayed if the system limits are reached.

Vehicle operating condition

Vehicle equipment

This chapter describes equipment, systems and functions which are offered or will be offered on a model-specific basis, even if they are not included in the vehicle in question.

For further information:

Vehicle equipment, see page 7.

General

Depending on the situation, the vehicle is in one of the three states:

- ▷ Rest state.
- ▷ Standby state.
- ▷ Drive-ready state.

Rest state

Principle

If the vehicle is in rest state, it is switched off.

General

The vehicle is in rest state before you open it from outside and once you have left the vehicle and locked it.

Safety notes

WARNING

An unsecured vehicle can start moving and rolling away. There is a risk of accident. Before leaving the vehicle, secure it to prevent it from rolling away.

Observe the following to ensure that the vehicle is secured against rolling away:

- ▷ Apply the parking brake.
- ▷ Turn the front wheels towards the kerb on upward or downward gradients.
- ▷ Additionally secure the vehicle on upward or downward gradients, for example with a chock.

WARNING

Unsupervised children or pets in the vehicle can set the vehicle in motion and endanger themselves or other road users, for example by the following actions:

- ▷ Pressing the Start/Stop button.
- ▷ Releasing the parking brake.
- ▷ Opening and closing doors or windows.
- ▷ Engaging selector lever position N.
- ▷ Operating vehicle equipment.

There is a risk of accident or injury. Do not leave children or pets unsupervised in the vehicle. When leaving the vehicle, take the vehicle key with you and lock the vehicle.

Establishing the rest state automatically

The rest state is established automatically, for example in the following situations:

- ▷ After a few minutes, if no operation is performed on the vehicle.
- ▷ When the vehicle battery state of charge is low.
- ▷ Depending on the iDrive setting: one or both of the front doors is opened when leaving the vehicle after a journey.

In some situations, for example during a telephone call or when the low-beam headlight is switched on, the vehicle will not switch automatically to rest state.

Establishing rest state on opening the front doors

After a trip, the rest state can be established by opening the front doors. For this purpose, all passengers must exit the vehicle.

1. "MENU"
2. "Vehicle apps"
3. "Doors and windows"
4. "Lock/unlock"
5. "Standby mode when doors opened"

Establishing the rest state manually

To establish rest state in the vehicle at the end of the journey:



Press and hold the button on the radio until the OFF display on the instrument cluster turns off.

With button on the radio



Press the button on the radio. The control display and instrument cluster illuminate.

With the Start/Stop button



Press the Start/Stop button. The control display and instrument cluster illuminate.

Display in the instrument cluster



OFF is shown in the instrument cluster. The drivetrain is switched off and standby state switched on.

Standby state

Principle

When standby state is activated, most functions can be operated while the vehicle is still stationary. Any desired settings can be performed.

General

The vehicle switches to standby state after the front doors are opened from the outside.

To preserve vehicle battery, use the standby state and activated power consumers only as long as absolutely necessary.

Manual standby state

General

The standby state can be switched on again after the rest state has been automatically established.

Drive-ready state

General



Drive-ready state is turned on or off with the Start/Stop button.

An active drive-ready state is the same as the engine running in conventional vehicles.

Deactivating drive-ready state is the same as switching off the engine.



If the drive-ready state is turned on, the vehicle ready to drive and READY is displayed in the instrument cluster.

All systems are operational.

To save vehicle battery power, switch off drive-ready state and any unnecessary power consumers when parking the vehicle.

Safety notes

WARNING

When driving using electric power, pedestrians and other road-users might not become aware of the vehicle as they normally would due to the lack of engine noise. There is a risk of accident. Adapt your driving style to the traffic conditions. Observe the traffic situation and intervene actively if the situation warrants it.

WARNING

An unsecured vehicle can start moving and rolling away. There is a risk of accident. Before leaving the vehicle, secure it to prevent it from rolling away.

Observe the following to ensure that the vehicle is secured against rolling away:

- ▷ Apply the parking brake.
- ▷ Turn the front wheels towards the kerb on upward or downward gradients.
- ▷ Additionally secure the vehicle on upward or downward gradients, for example with a chock.

WARNING

Unsupervised children or pets in the vehicle can set the vehicle in motion and endanger themselves or other road users, for example by the following actions:

- ▷ Pressing the Start/Stop button.
- ▷ Releasing the parking brake.
- ▷ Opening and closing doors or windows.
- ▷ Engaging selector lever position N.
- ▷ Operating vehicle equipment.

There is a risk of accident or injury. Do not leave children or pets unsupervised in the vehicle. When leaving the vehicle, take the vehicle key with you and lock the vehicle.

NOTE

Selector lever position P is automatically engaged when standby state is switched off. There is a risk of material damage. Do not switch off standby state in car washes.

Switching on drive-ready state

1. Close the driver's door.
2. Press the brake.
3. Press the Start/Stop button.

Most of the indicator and warning lights in the instrument cluster illuminate for varying lengths of time.

READY is displayed in the instrument cluster and an acoustic signal sounds.

Drive-ready state is switched on.

Switching off drive-ready state

After stopping:

1. Press the brake and engage selector lever position P.
2. Apply the parking brake.
3. Press the Start/Stop button.

The READY display is no longer illuminated and an acoustic signal is heard.

Drive-ready state is automatically switched off if the driver's door is opened while driver's seat belt is unfastened.

iDrive

Vehicle equipment

This chapter describes equipment, systems and functions which are offered or will be offered on a model-specific basis, even if they are not included in the vehicle in question.

For further information:

Vehicle equipment, see page 7.

Operating concept

Principle

iDrive is the operating concept of the infotainment system and includes a large number of functions.

General

These functions can be operated as follows:

- ▷ Via the Controller.
- ▷ Via the touchscreen.
- ▷ Via the BMW Intelligent Personal Assistant.
- ▷ Via buttons on the steering wheel
Instrument cluster, see page 153.

Safety note

WARNING

Operating integrated information systems and communication devices during a journey may distract you from the road. You could lose control of the vehicle. There is a risk of accident. Only operate the systems or devices if the traffic conditions allow you to do so. Stop if necessary and operate the systems or devices with the vehicle at a standstill.

Main menu

Overview

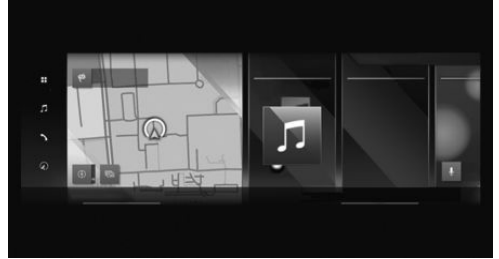

Menu

■ Access to apps and vehicle functions. A filter for "All apps" and "Vehicle apps" can be selected. In the area "All apps", all apps and functions are displayed. In the area "Vehicle apps", only functions for vehicle settings are filtered. The last selected filter is stored. If necessary, change to the area "All apps" to display all apps and functions.

Media

🎵 Access to functions of the entertainment system, for example radio stations or connection with external devices.

Telephone

📞 Access to the telephone and message function as well as the connection and management of mobile devices, for example smartphones.

Navigation

📍 Access to navigation system, destination entry and traffic information. Configurable map views as well as other functions, for example points of interest.

Apple CarPlay

▶ With connected function: access to Apple CarPlay. Apple CarPlay allows certain functions of a compatible Apple iPhone to be used securely via iDrive.

Android Auto

▲ With connected function: access to Android Auto. Android Auto enables certain functions of a compatible Android smartphone to be used securely via iDrive.

Widgets





Widgets show real-time information and dynamic content, for example the map of the navigation system. The widgets also serve as buttons and allow jumping to the relevant menu.

Status information



General



The status field is located in the top area of the control display. Status information is displayed in the form of icons.

Telephone status information





Icon	Meaning
	Active call.
	Data transfer not possible.
	Signal strength.
	SIM card missing.

Entertainment status information

Icon	Meaning
	USB audio.
	Bluetooth audio.
	Smartphone audio.

Icon	Meaning
	Connected Music.
	Apple CarPlay.
	Android Auto.







Status information notifications

Icon	Meaning
	Check Control message.
	Traffic information.
	Suppress private information.
	Do not disturb.

For further information:

Owner's Handbook for Navigation, Entertainment, Communication, see page 6.







Other status information

Icon	Meaning
	Sound output active.
	Sound output deactivated.
	Activation word active.
	BMW ID or driver profile.
	Route guidance active.
	Quicklist.
	Wireless charging active.

Digit input and display

Letters and numbers

Letters and numbers can be entered using the Controller, the touchpad, touchscreen or voice control.







Icon	Function
	To switch between upper and lower case.
	To enter a space.
	To switch between languages.
	To use voice input.
	To confirm your digit input.
	Move the entry area to the left or right.

Input comparison

When entering data from a database, for example contacts, the selection is gradually narrowed down with each character entered and supplemented if necessary.

Activating/deactivating functions

Some menu items are preceded by an icon. Selecting the menu item enables or disables the function.

Icon	Meaning
  	Function is activated.
  	Function is deactivated.

Quick access

The quicklist provides access to the shortcuts, certain settings and app recommendations.

Digit input	Operation
Show	Swipe from top to bottom on the quicklist. Tilt the Controller up.
Hide quicklist.	Swipe from the bottom up on the control display. Tilt the Controller down.

Activating/deactivating pop-ups

Pop-ups are automatically shown on the control display for some functions. Some of these pop-ups can be activated or deactivated.

1. "MENU"
2. "Vehicle apps"
3. "System settings"
4. "Pop-ups"
5. Select the desired setting.

Shortcuts

General

The iDrive functions can be stored on the shortcuts and called up directly, for example, radio stations, navigation destinations, phone numbers and menu entries.

Saving a function

1. Select the desired function.
2. "Add to shortcuts"

Shortcuts can only be created with an active BMW ID or a driver profile.

Performing a function

1. Swipe from top to bottom on the control display.
2. Tap the desired shortcut.

The function is carried out immediately. If you have selected a phone number for example, the connection will also be established.

Deleting shortcuts

1. Swipe from top to bottom on the control display.
2. Press and hold the desired shortcut.
3. "Delete shortcut"

Control display

Principle

The iDrive functions are shown on the control display.

Safety note

NOTE

Objects located in front of the control display may slip and damage the control display. There is a risk of material damage. Do not place objects in front of the control display.

Overview

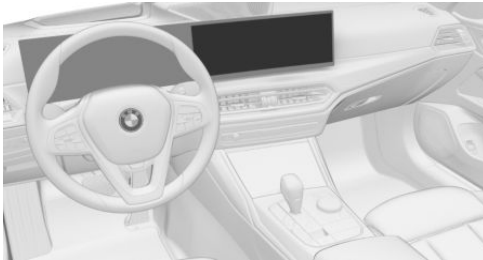

Control display

Switching on/off automatically

The control display is switched on automatically when the vehicle is unlocked or as soon as the control display is required for operation.

In certain situations, the control display is switched off automatically, for example if no operation is performed on the vehicle for several minutes.

Switching on/off manually

The control display can be turned off manually.

1. Swipe from top to bottom on the control display.
2. "Screen off"

Tap the control display to turn it on again.

Adjusting the brightness

1. "MENU"
2. "Vehicle apps"
3. "Displays"
4. "Control display"
5. "Brightness at night"
6. Confirm the desired setting.

Depending on the lighting conditions, the brightness control may not be immediately apparent.

System limits

If the control display is exposed to very high temperatures, for example because of strong sunlight, the brightness may be reduced and the control display may even switch itself off. Normal functions will be restored when the temperature is reduced, for example by shading or using the air conditioning system.

Controller

General

The buttons can be used to call up menus directly. The Controller can be used to select menu items and perform settings.

Some of the functions of the iDrive can be operated with the touchpad of the Controller.

Overview



Controller

Buttons on the Controller

Button	Function
HOME	To go to the main menu.
MEDIA	To go to the Media/Radio menu.
TEL	To go to the Telephone menu.
MAP	To go to the navigation map.
NAV	To go to the destination entry menu of the navigation system.
BACK	Go to previous display area.
OPTION	To go to the Options menu.

Operation

- ▶ Turn to switch between menu items, for example.

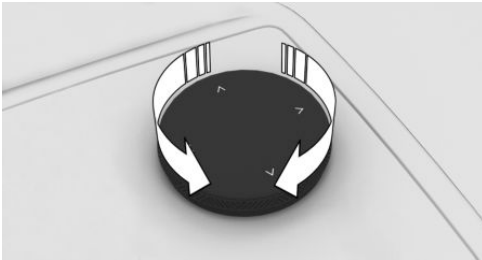

- ▶ Press to select a menu item, for example.

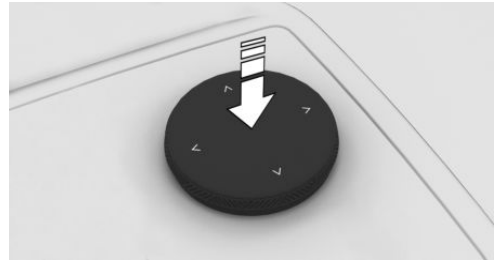

- ▶ Tilt in four directions to change between display ranges, for example.

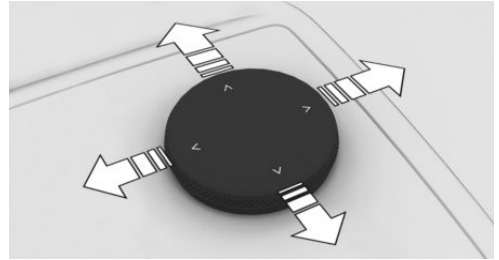

Operation using the Controller

Accessing the main menu

- ▶ **HOME** Press the button.

The main menu is displayed.

Selecting menu items

1. Turn the Controller until the desired menu item is highlighted.
2. Press the Controller.

Selecting widgets

1. In the main menu, tilt the Controller to the right.
2. Turn the Controller until the desired widget is selected.
3. Press the Controller.

Changing between display areas

After a menu item has been selected, for example "System settings", a new display area will be displayed.

- ▶ Tilt the Controller to the left.
The current display area closes and the previous display area is shown.



- ▶ Press the button.
The previous display area re-opens.

Entering letters and numbers

Digit input

1. Turn the Controller: to select letters or numbers.
2. **OK** : to confirm your digit input.

Set system language, see page [63](#).

Deleting

Icon	Function
	Press Controller: to delete a letter or number.
	Press and hold the Controller: to delete all letters or numbers.

Using alphabetical lists

For alphabetical lists with more than 30 entries, the letters for which entries exist can be displayed in a letter field.

1. Turn the Controller quickly to the left or right.
2. Select the first letter of the desired entry.
The first entry for the selected letter is displayed in the list.

Operation by touchpad

General

Some of the functions of the iDrive can be operated with the touchpad of the Controller.

Selecting functions

1. "MENU"
2. "Vehicle apps"
3. "System settings"
4. "Touchpad"
5. Select the desired setting.

Entering letters and numbers

- ▶ Enter characters as they are displayed on the control display.
- ▶ Always enter associated characters, for example accents or dots, so that the letter can be clearly identified.
- ▶ The input options depend on the set language. You may need to enter special characters using the Controller.
Set system language, see page [63](#).

Entering special characters

Function	Operation
To delete a character.	Swipe to the left on the touchpad.
To enter a space.	From the centre of the touchpad, swipe to the right.
To enter a hyphen.	At the top of the touchpad, swipe to the right.
To enter an underscore.	At the bottom of the touchpad, swipe to the right.

Using the map

The navigation system's map can be moved using the touchpad. Tap the map on the control display and then continue the operation using the touchpad.

Function	Operation
To move the map.	Swipe in the appropriate direction.
To display the menu.	Tap once.

Using alphabetical lists

Alphabetical lists with more than 30 entries permit a direct jump to letters for which an entry exists.

Enter the first letter on the touchpad.

The first entry of the entered letter is displayed in the list.

Operation by touchscreen

General

The control display is equipped with a touchscreen.

It is possible to tap menu items and widgets. Touch the touchscreen with your fingers. Do not use any objects.

Calling up the main menu



 Tap the symbol.

The main menu is displayed.

Adapting widgets

You can adapt the widgets in the main menu. It is only possible to make adaptations with the vehicle at a standstill.

1. If necessary,  tap the icon.
2. Press and hold the widget.
3. Make the desired adjustment:

- ▶  Tap the icon.
A new widget can be selected.
- ▶  Tap the icon.
The widget is deleted.
- ▶ Press and hold the widget and drag to the left or right.
The widget is moved to the desired position.

Go to Context menu

Depending on the menu item, a context menu with additional options can be displayed.

Press and hold the desired menu item.

The menu consists of various areas, such as:



- ▶ "Help": go to the Integrated Owner's Handbook.
- ▶ "Add to shortcuts": define menu item as shortcut.

Entering letters and numbers

Digit input

1. Tap  icon or touchscreen if necessary.
2. Enter the required letters and numbers.

Deleting

Icon	Function
	Tap icon: to delete a letter or number.
	Press and hold the icon: delete all letters or numbers.

Using the map

The navigation map can be moved using the touchscreen.

Function	Operation
To move the map.	Swipe in the appropriate direction.
To zoom in/out on the map.	Pinch together or move apart your fingers.
To display the menu.	Tap once.

Using alphabetical lists

For alphabetical lists with more than 30 entries, the letters for which entries exist can be displayed in a letter field.

1. Tap the letter in front of the list.
A letter box is displayed.
2. Tap the first letter of the desired entry.
The first entry for the selected letter is displayed in the list.

BMW Intelligent Personal Assistant

Principle

The BMW Intelligent Personal Assistant is a personal assistant that enables natural voice control of various vehicle functions. The Personal Assistant simplifies the operation of the vehicle with the automation of processes and routines.

General

- ▶ BMW Intelligent Personal Assistant is available depending on the national-market version.
- ▶ The system includes special microphones on the driver's side and the passenger's side.
- ▶ Say commands at a normal volume. Speaking directly into the microphone does not improve the speech recognition.

- ▶ Commands and numbers should be spoken fluently, with the usual emphasis and at a normal volume and speed.
- ▶ ›...‹ identifies commands that can be spoken.

Operating requirements

- ▶ A system language that is supported by the Personal Assistant must be set via iDrive.
Set system language, see page 63.
- ▶ Always say commands in the configured system language.

For the full range of functions, the following functions should be activated, set or booked:

- ▶ Online speech processing, see page 64.
- ▶ All settings under
Data protection, see page 70.
- ▶ Activation word, see page 62.
- ▶ BMW ID or a driver profile.
- ▶ Relevant ConnectedDrive Services via the ConnectedDrive Store.

Activating voice input

General

Voice input can be activated in various ways:

- ▶  Press the button on the steering wheel briefly.
The microphone on the driver's side is active.
- ▶ Say the activation word.
The microphones on the driver's or front passenger's side are active with the following voice control, depending on where the activation word was spoken.

Then say the command. The activation word and the command can be spoken without pause in one sentence.

Button on the steering wheel



1. Press the button briefly.
2. Say the command.

Activation word

General

Saying the activation word starts the Personal Assistant. The Personal Assistant listens.

Preset activation word

The preset activation word ›Hello BMW‹ can be activated and deactivated.

1. "MENU"
2. "Vehicle apps"
3. "System settings"
4. "Personal Assistant"
5. "Activation word"
6. ""Hello BMW""

Personal activation word

In addition to the preset activation word, a personal activation word can be set up with an active BMW ID or a driver profile. The personal activation word can also be changed or deleted.

The activation word should consist of multiple syllables to ensure good detection. An addition, such as ›Hello‹ is not necessary.

1. "MENU"
2. "Vehicle apps"
3. "System settings"
4. "Personal Assistant"
5. "Activation word"
6. "Personal activation word"
7. "Set"
8. "Start recording"

Activation word from third-party providers

Depending on the national-market version, some third-party providers provide digital voice assistants, for example, Siri, Amazon Alexa or Google Assistant.

Supported voice assistants can be used with a connected smartphone in the vehicle. In addition to the preset or personal activation word, the activation word of voice assistants from connected third-party providers can be used.

1. "MENU"
2. "Vehicle apps"
3. "System settings"
4. "Third-party providers"
5. Select the desired setting.

Cancelling voice input



- ▷ Press the button on the steering wheel again.
- ▷ ›Cancel‹
- ▷ Tilt the controller to the right or left.
- ▷ Press the Controller.

Possible commands

General

Most of the contents on the control display, for example menu items and list entries, can be said as commands. Say list entries as shown.

Instructions can be issued or questions can be asked where the Personal Assistant provides support.

Vehicle status and vehicle functions

- ▷ ›Is my tyre pressure still OK?‹
- ▷ ›Show me the sport displays.‹
- ▷ ›Open Owner's Handbook.‹

Navigation

- ▶ ›Drive me to 1 High Street in Manchester.‹
- ▶ ›Take me home.‹
- ▶ ›Are there any traffic messages?‹

Communication

For example, when a mobile phone is connected, calls can be started or SMS can be sent.

- ▶ ›Call John Smith on the mobile phone.‹
- ▶ ›Dial the number 0370 505 0160.‹
- ▶ ›New text message to John Smith: I'm on my way.‹

Entertainment

- ▶ ›What song is this?‹
- ▶ ›Play Blue Suede Shoes by Elvis Presley.‹
- ▶ ›Next track.‹

Air conditioning

- ▶ ›Turn off air conditioning.‹
- ▶ ›Activate fresh air.‹
- ▶ ›I'm cold.‹

Windows and light

- ▶ ›Open [the] windows automatically.‹
- ▶ ›Activate the automatic driving lights.‹

Owner's Handbook by voice control

It is possible to ask simple questions about the vehicle functions and about operating the vehicle.

The voice control system and the feedback it provides are not a substitute for the printed or integrated Owner's Handbook. The speech recognition function and the quality of the feedback may vary.

›How do you disable the front passenger airbag?‹

The Personal Assistant gives a response. Where applicable, the section of the integrated Owner's Handbook is displayed on the control display if the vehicle is at standstill.

Menu items

Say the commands of the menu items as they are selected via the control display.

1. Activate the voice input.
2. ›Media‹
3. ›Saved stations‹
The saved stations are displayed on the control display.

Help for voice control

- ▶ ›Voice commands; Sample commands: to have voice command options read aloud.
- ▶ ›General information on voice control: have information on the operating principle of the voice control announced.
- ▶ ›Help: have tips and example commands for voice control announced.
- ▶ Additional example commands for the current context are displayed in the widget of the BMW Intelligent Personal Assistant.

Settings

Setting the system language

1. "MENU"
2. "Vehicle apps"
3. "System settings"
4. "Language"
5. Select the desired setting.

Setting the response length

You can set the Personal Assistant to use the standard dialogue or a short version. In case of the short version, the announcements by the Personal Assistant are played back in an abbreviated version.

1. "MENU"
2. "Vehicle apps"
3. "System settings"
4. "Personal Assistant"

5. "Response length"
6. Select the desired setting.

Saying during voice output

It is possible to answer during inquiries of the Personal Assistant. The function can be deactivated if the feedback is frequently cancelled inadvertently, for example due to background noise or conversations in the vehicle.

1. "MENU"
2. "Vehicle apps"
3. "System settings"
4. "Personal Assistant"
5. "Speaking during voice output"

Online speech processing

Online speech processing improves the quality of the speech recognition and search results for points of interest. To use the function, data is sent across an encrypted connection to a service provider where it is then stored.

1. "MENU"
2. "Vehicle apps"
3. "System settings"
4. "Personal Assistant"
5. "Online speech processing"

Adjusting the volume

Turn the volume control button during the spoken instructions until the desired volume is obtained.

The volume setting is retained even if you change the volume of other audio sources.

Using the voice control of the smartphone

Depending on the device, a smartphone connected to the vehicle can be operated via voice input.

The device must be connected via Apple CarPlay or Android Auto.



1. Press and hold the button on the steering wheel for approx. 3 seconds.

The voice control of the smartphone is activated.

If activation is successful, a confirmation appears on the control display.



2. Press the button on the steering wheel to cancel the voice control of the smartphone.

Automating habits

General

The Personal Assistant can automate routines, for example, the automatic opening of windows at the same place. This involves creating rules that can be activated and deactivated at any time.

Activating/deactivating routines

1. "MENU"
2. "All apps"
3. "Automate habits"
4. Select the desired setting.

System limits

- ▶ The Personal Assistant provides information about vehicle functions that may not be installed in the vehicle.

This also applies to safety-relevant functions and systems.

- ▶ Certain noises may be detected and could cause problems. Keep doors and windows closed.
- ▶ Noises from the front passenger or other passengers can impair the system. Avoid

background noise in the vehicle while you are speaking.

- ▶ Strong dialects may prevent speech recognition from working properly.
- ▶ A poor data connection influences the response time of the Personal Assistant and the Search.

BMW Remote Software Upgrade

Vehicle equipment

This chapter describes equipment, systems and functions which are offered or will be offered on a model-specific basis, even if they are not included in the vehicle in question.

For further information:

Vehicle equipment, see page 7.

BMW Remote Software Upgrade

Principle

Remote Software Upgrade can be used to update the entire software of the vehicle. This makes new functions, functional enhancements or quality improvements available.

General

BMW recommends carrying out the Remote Software Upgrade as soon as it becomes available.

Safety note

WARNING

Unsupervised children or pets in the vehicle can set the vehicle in motion and endanger themselves or other road users, for example by the following actions:

- ▷ Pressing the Start/Stop button.
- ▷ Releasing the parking brake.
- ▷ Opening and closing doors or windows.
- ▷ Engaging selector lever position N.
- ▷ Operating vehicle equipment.

There is a risk of accident or injury. Do not leave children or pets unsupervised in the vehicle. When leaving the vehicle, take the vehicle key with you and lock the vehicle.

Operating requirements

- ▷ Active ConnectedDrive contract.
- ▷ The integrated SIM card in the vehicle has been activated.
- ▷ Mobile reception.
- ▷ A consent for the transmission of the corresponding data was given in the Data Protection menu.

Search for an upgrade

The standby state must be turned on to search for a software upgrade.

Automatic search

The vehicle regularly searches for updates in the background.

Manual search

1. "MENU"
2. "All apps"
3. "System settings"
4. "Remote Software Upgrade"
5. "Search for upgrades"
6. Follow the instructions on the control display.

Download of an upgrade

Automatic download

If available, the data for a Remote Software Upgrade is automatically downloaded to the vehicle. There is no need to consent to the download.

Via BMW app

If an upgrade is available, information about the new software version is displayed in the BMW app.

The data for the upgrade can then be downloaded to a mobile device, for example via an existing Wi-Fi connection.

The data can then be transferred from the mobile device to the vehicle.

This transmission method accelerates the download of the data, for example in areas with limited mobile network availability.

1. Download the upgrade in the BMW app to the smartphone.
2. Follow the instructions in the BMW app.
3. Establish the connection to the vehicle.
 - ▷ iOS: connect Bluetooth audio and WLAN.
 - ▷ Android: connect Bluetooth® audio and WLAN.

The data transfer of the upgrade from the mobile device to the vehicle occurs in the background only while driving.

4. Follow the instructions on the control display.

For further information:

Connect mobile devices to the vehicle, see page 75.

Version information

General

The version information describes the updates contained in the Remote Software Upgrade. The version information can be shown on the control display during the download and following successful completion of the installation.

This information is also available in the ConnectedDrive customer portal.

Displaying information

Display in the vehicle:

1. "MENU"
2. "All apps"
3. "System settings"
4. "Remote Software Upgrade"
5. ▷ Display currently installed version:
 - "Installed version:"
 - ▷ Display new available version: "Info on version"
6. Follow the instructions on the control display.

Display in the ConnectedDrive customer portal on the Internet:

www.bmw-connecteddrive.com.

Installing the upgrade

General

- ▷ Installing the upgrade may cause software modifications not made by the vehicle manufacturer to be deleted (increases in performance, for example).
- ▷ Modifications to the on-board power supply of the vehicle, for example to control units that have not been made by the manufacturer of the vehicle, can cause the installation to malfunction.
- ▷ Installation can take around 20 minutes.
- ▷ Installation cannot be interrupted.
- ▷ The vehicle cannot be used during installation.
- ▷ You may leave the vehicle during installation.
- ▷ The installation does not occur until the consent was given.
- ▷ The vehicle charging process is interrupted by the installation.
- ▷ Following the successful installation, charging the vehicle may not continue automatically.

Prerequisites for the installation

- ▷ The vehicle battery is sufficiently charged.
- ▷ Outside temperature is above -10 °C/14 °F.
- ▷ Vehicle is standing on level ground.
- ▷ Hazard warning lights are turned off.
- ▷ Selector lever position P is engaged.
- ▷ Drive-ready state is turned off.

If applicable, follow the notes for further prerequisites on the control display.

If the prerequisites are not met, for example a sufficient vehicle battery charge state, the upgrade will not be offered for installation.

Pay attention to an offer for installation, for example after extended charging of the battery.

Preparing the vehicle

- ▷ Park the vehicle safely away from the public road.
- ▷ Cellular network reception must be ensured so that a fault message can be sent to the vehicle manufacturer, for example if the installation is terminated.
- ▷ Close the windows.
- ▷ Close the glass sunroof.
- ▷ Closing the luggage compartment
- ▷ Remove devices that consume energy, for example mobile phone.
- ▷ Disconnect the trailer or load carrier.
- ▷ The vehicle key must be located in the vehicle for the consent for installation.
- ▷ Switch off the exterior lights.
- ▷ Remove connected devices from the OBD socket.

Install immediately

The upgrade can be installed immediately when all prerequisites have been met.

1. "MENU"
2. "All apps"

3. "System settings"
4. "Remote Software Upgrade"
5. "Start upgrade now"
6. Follow the instructions on the control display.

Installing with timer

At the end of the journey, a timer can be used to install the upgrade automatically at a configured time, for example, during the night. A later installation may make sense to meet functional requirements, for example, a sufficiently charged vehicle battery.

1. "MENU"
2. "All apps"
3. "System settings"
4. "Remote Software Upgrade"
5. Enter the desired timer settings.

The installation starts automatically when:

- ▷ All prerequisites for the installation have been established correctly.
- ▷ All prerequisites continue to be met at the time of installation.

The timer is turned off when the drive-ready state is turned on.

Functional limitations

During the upgrade, many of the functions are temporarily unavailable, for example:

- ▷ Hazard warning lights.
- ▷ Central locking system and, if necessary, Comfort Access.
- ▷ Side lights.
- ▷ Horn.
- ▷ Alarm system.
- ▷ Emergency call.
- ▷ Electric windows.
- ▷ Glass sunroof.
- ▷ Operating the tailgate or boot lid.
- ▷ Locking the tailgate.

The driver's door can be unlocked and locked from outside with the integrated key.

After successful upgrade

The vehicle can be used again immediately.

Booked services, for example, RTTI or Remote Services, will be reactivated automatically during the next trip.

After a longer stationary period, recharge the vehicle battery with the charging cable if necessary.

Malfunction

In the event of a malfunction, follow the instructions on the control display or in the BMW app.

If the malfunction cannot be rectified, contact a Service Partner of the manufacturer or another qualified Service Partner or a specialist workshop.

Validity of Owner's Handbook

Vehicle production

When the vehicle leaves the factory, the contents of the printed Owner's Handbook are up to date.

After a software update in the vehicle

After a vehicle software update, for example, via Remote Software Upgrade, the Integrated Owner's Handbook for the vehicle will contain the latest information.

Personal settings

Vehicle equipment

This chapter describes equipment, systems and functions which are offered or will be offered on a model-specific basis, even if they are not included in the vehicle in question.

For further information:

Vehicle equipment, see page 7.

Data protection

Data transfer

Principle

The vehicle offers various services which require data to be transferred to BMW or a service provider. Data transfer can be deactivated for some services.

General

If data transfer has been deactivated for a service, then that service cannot be used.

Only perform settings with the vehicle at a standstill.

Settings

Data transfer can be configured individually in various stages or for individual services.

1. "MENU"
2. "Vehicle apps"
3. "System settings"
4. "Data privacy"
5. Select the desired setting.

Deleting personal data in the vehicle

Principle

Depending on use, the vehicle stores personal data such as saved radio stations. This personal data can be permanently deleted using iDrive.

General

Depending on the equipment, the following data is deleted:

- ▶ BMW IDs or driver profiles.
- ▶ Saved radio stations.
- ▶ Stored shortcuts.
- ▶ Navigation, for example saved destinations.
- ▶ Phone book.
- ▶ Online data, for example favourites, cookies.
- ▶ Office data, for example voice memos.
- ▶ Login accounts.
- ▶ Linking the vehicle with the BMW Cloud.

It may take up to 15 minutes in total to delete data.

Operating requirements

Data can only be deleted with the vehicle at a standstill. The vehicle key must be in the vehicle.

Deleting data

Personal data in the vehicle is deleted when the vehicle is reset to its factory settings.

For further information:

Reset vehicle data, see page 71.

Resetting vehicle data

All individual settings can be reset to the factory settings when drive-ready state is switched off. The vehicle key must be in the vehicle.

1. "MENU"
2. "Vehicle apps"
3. "System settings"
4. "Reset vehicle data"
5. "Reset vehicle data"

When the stored settings in a BMW ID are synchronised with the settings in the BMW Cloud, the settings will remain in the BMW Cloud.

BMW ID/driver profiles

Principle

In ConnectedDrive countries, the BMW ID is the personal login for all relevant offers for the BMW brand. The BMW ID can be used in the vehicle to store personal vehicle settings.

In non-ConnectedDrive countries, the personal vehicle settings can be stored in driver profiles.

When a person logs in with their BMW ID or the driver profile in the vehicle, the stored settings are activated.

General

The BMW ID can be created in the vehicle, via the BMW app, in the ConnectedDrive portal and at the Service Partner. A driver profile is created in the vehicle.

If a vehicle is used by multiple persons, each person can activate their own personal settings via the BMW ID or via the driver profile.

Many of the settings that are stored for a BMW ID in the vehicle can be synchronised with the BMW Cloud. This makes these settings available in any vehicle where the same BMW ID is used to log in.

The vehicle can store three BMW IDs or three driver profiles.

If a login using the BMW ID does not occur and no driver profile is activated, the vehicle is in the guest profile.

The login with the BMW ID or the activation of the driver profile can already occur during unlocking. For this purpose, the driver recognition via a vehicle key or a digital key must be assigned to the BMW ID or the driver profile.

Operating requirements

When a BMW ID or driver profile is created, changed, deleted or edited, the vehicle must move at a maximum of walking speed.

The login in the vehicle with a BMW ID and synchronisation with the BMW Cloud are only possible when the vehicle has cellular network reception.

Welcome window

After unlocking the vehicle, a Welcome window is shown on the control display. The type of the welcome depends on the following prerequisite:

- ▶ The vehicle does not have a stored BMW ID or driver profile:

The welcome is neutral. An option to add a BMW ID or create a driver profile is offered.

- ▶ The vehicle key or the digital key has not been assigned to a BMW ID or a driver profile:

The welcome is neutral. The stored BMW IDs or the stored driver profiles are offered for selection. Additionally, it is possible to add a new BMW ID or create a new driver profile.

- ▶ The vehicle key or the digital key could be assigned to a BMW ID or a driver profile:

The welcome is personalised, the stored settings are activated. The BMW ID or the driver profile can be changed.

As soon as the drive-ready state is turned on or the control display is tapped outside of the welcome window, the welcome will be hidden.







Creating a BMW ID

A new BMW ID must be created in the vehicle.

1.  Tap the icon or personal picture in the status bar.
2. "Add BMW ID"
3. "Register now"
4. Scan the QR code shown in the display. The BMW ID is created on the smartphone.

Adding the BMW ID

Adding an existing BMW ID to the vehicle:

1.  Tap the icon or personal picture in the status bar.
2. "Add BMW ID"
3.  "Log in with My BMW App"
Scan the displayed QR code to accept the BMW ID from the BMW app.
 -  "Log in with BMW ID"
Enter the login data of the BMW ID.
4. Depending on the national-market version, the following settings can be selected:
 -  "Settings from BMW Cloud"
The settings stored in the BMW Cloud are applied.
 -  "Current settings"
If the vehicle is in the guest profile, the settings of the guest profile will be applied.
 -  "Synchronise BMW ID"
Future changes to the settings are synchronised with the BMW Cloud.
 -  "Continue"

Creating a driver profile

A driver profile must be created.



1.  Tap the icon or personal picture in the status bar.
2. "ADD DRIVER PROFILE"

3. Enter the name for the driver profile.
4. Select the desired setting:
 - "Current settings"
 If the vehicle is in the guest profile, the settings of the guest profile will be applied.



Specify the driver detection

A driver detection and a PIN can be set up for a BMW ID or a driver profile.

The driver detection offers the following advantages:

-  The stored settings are activated automatically.
-  The settings are not accessible to other persons.
-  The PIN can be used to activate the BMW ID or the driver profile, even if the assigned vehicle key or the assigned digital key is not available.

The driver detection is specified immediately following the addition of the BMW ID or after creating the driver profile.

-  "PIN"
Prior to the selection of the driver detection, a PIN must be created.
-  "Vehicle key"
The vehicle key that is recognised in the vehicle interior is assigned to the BMW ID or the driver profile.
-  "Digital Key"
The digital key that is recognised in the vehicle interior is assigned to the BMW ID or the driver profile.

Automatic driver recognition

If driver recognition has been defined, the automatic activation of the BMW ID or the driver profile is triggered by the following activities:

- ▶ By unlocking the vehicle using the assigned vehicle key button.
- ▶ By unlocking the vehicle using an outside door handle. The assigned vehicle key or the assigned digital key must be carried.
- ▶ By automatic unlocking when approaching the vehicle. The assigned vehicle key or the assigned digital key must be carried. Depending on the national-market version, it may not be possible to recognise the digital key.

If there are several vehicle keys or digital keys in the vicinity of the vehicle, the activation of the BMW ID or the driver profile takes place according to the following priority:

- ▶ The key that unlocks the vehicle triggers the activation of the assigned BMW ID or the assigned driver profile.
If the vehicle is unlocked using an unassigned key, the guest profile is activated.
- ▶ If a vehicle key and a digital key are detected at the same time, the digital key triggers the activation of the assigned BMW ID or the assigned driver profile.
- ▶ If another key is detected on the driver's door after activating the BMW ID or the driver profile, the BMW ID or the driver profile of the last key detected is activated.
If no BMW ID and no driver profile are assigned to this key, the guest profile is activated.

Selecting the BMW ID/driver profile

If detection was not possible while unlocking the vehicle, the BMW ID or driver profile is selected on the welcome window.

The BMW ID or driver profile can be changed at any time via iDrive:

1.  Tap the icon or personal picture in the status bar.
2. ▶ "Change BMW ID"
 - ▶ Switch the driver profile.

3. Select the BMW ID or driver profile.
4. If necessary, enter the PIN.

The BMW ID or the driver profile are activated, the stored settings are loaded.

Guest profile

The guest profile can be activated and changed by anyone.

The guest profile is automatically active in the following cases:

- ▶ A BMW ID has not yet been added or a driver profile has not yet been created.
- ▶ No BMW ID or driver profile has been assigned to the vehicle key or the digital key that was used to unlock the vehicle.





The following limitations apply to the guest profile:

- ▶ Functions that process personal data are not available to protect sensitive, personal data from unauthorised access. This includes select functions of the navigation and the saving of favourites. More information on data processing is available in the ConnectedDrive data protection notes / service descriptions.
- ▶ The guest profile cannot be renamed.
- ▶ It is not possible to assign a PIN to the guest profile.
- ▶ It is not possible to assign a driver detection to the guest profile.
- ▶ In ConnectedDrive countries, the synchronisation with the BMW Cloud is not possible.

The guest profile is selected in the welcome window or via iDrive:

1.  Tap the icon or personal picture in the status bar.
2. ▶ "Change BMW ID"
 - ▶ Switch the driver profile.
3. "Continue as guest"

Deleting the BMW ID/driver profile

1.  Tap the icon or personal picture in the status bar.
2.  "Change BMW ID"
 -  Switch the driver profile.
3.  Tap the icon of the desired BMW ID or the desired driver profile.

If the BMW ID was synchronised with the BMW Cloud, the stored data in the BMW Cloud will be retained.

After the deletion, the guest profile will be activated.

Transfer of the vehicle key

A vehicle key that is assigned to a BMW ID or a driver profile can be used to view or change the stored personal settings.

Before a vehicle key is transferred to other persons, any assigned driver detection should be cancelled. Changes to the driver detection can be made in the settings of the BMW ID or the driver profile.

The BMW Digital Key provides the option to transfer a digital key to permit other persons the use of your own vehicle.

For further information:

BMW Digital Key, see page [96](#).



Settings



General

Settings added when adding a BMW ID or creating a driver profile can be changed.



1.  Tap the icon or personal picture in the status bar.
2. "Settings"

The following settings are available for the BMW ID:

-  The type of driver detection.
-  The profile picture.

-  The synchronisation with the BMW Cloud.
-  The personal salutation.

The following settings are available for the driver profile:

-  The type of driver detection.
-  The profile picture.
-  The profile name.





Selecting a profile picture

The profile picture can be selected from the predefined profile pictures.

The personal profile picture from the BMW Cloud can be applied to a BMW ID. This requires that the synchronisation with the BMW Cloud is activated in the settings. After the profile picture from the BMW Cloud has been applied, a selection from the predefined pictures is only possible if the profile picture in the BMW Cloud is deleted.

System limits

A clear driver detection via the vehicle key or the digital key may not always be possible, for example in the following cases:

-  The driver unlocks the vehicle at the outside door handle.
-  If there is a change of driver without the vehicle being locked and unlocked.
-  When multiple vehicle keys or multiple digital keys with an assigned BMW ID or driver profile are located in the outer area on the driver's side of the vehicle.
-  When the vehicle was unlocked from the BMW app.

The use of personal settings that are stored for a BMW ID in other vehicles is subject to technical limitations. For example, there may be stored settings for a system that is not available in other vehicles, or only in an incompatible version.

Connections

Vehicle equipment

This chapter describes equipment, systems and functions which are offered or will be offered on

a model-specific basis, even if they are not included in the vehicle in question.

For further information:

Vehicle equipment, see page 7.







Connecting mobile devices to the vehicle

Principle

The vehicle offers various types of connections for using mobile devices. Which connection type to select depends on the mobile device and the function you wish to use.

General

The following list shows possible functions and the appropriate connection types for them. The range of functions depends on the vehicle equipment and the mobile device.

Function	Connection type	Icon on the control display
Making calls using the hands-free system. Operating telephone functions via iDrive or by voice control. Other functions, for example managing contacts or texting.	Bluetooth.	
Playing music from the smartphone or audio system.	Bluetooth audio.	
Internet: Use Internet access via the personal hotspot.	Internet via WiFi.	
Apple CarPlay: Operating iOS apps via iDrive and by voice control.	Apple CarPlay via Bluetooth and WiFi.	
Android Auto: Operating Android apps via iDrive and by voice control.	Android Auto via Bluetooth and WiFi.	
USB port: Playing music from a USB device.	USB.	

Paired devices are then automatically recognised and connected to the vehicle.

Safety note

WARNING

Operating integrated information systems and communication devices during a journey may distract you from the road. You could lose control of the vehicle. There is a risk of accident. Only operate the systems or devices if the traffic conditions allow you to do so. Stop if necessary and operate the systems or devices with the vehicle at a standstill.

Compatible devices

General

Information on compatible mobile devices is available as follows:

- ▶ On the BMW homepage.
- ▶ Via the hotline/customer support.
- ▶ A Service Partner of the manufacturer or another qualified Service Partner or a specialist workshop.

Managing mobile devices

General

- ▶ Following one-off pairing, the devices are automatically detected and connected again when standby state is switched on.
- ▶ The data saved on the SIM card or in the mobile phone – for example, contacts – is transferred to the vehicle following detection and can be used via iDrive.
- ▶ For some mobile devices, certain settings are necessary directly on the device, for example, authorisation, see the operating instructions of the device.

Displaying the device list





All devices paired or connected to the vehicle are displayed in the device list.

A maximum of four devices can be connected to the vehicle via Bluetooth and ten devices via WLAN. A maximum of 20 devices can be detected.

1. "MENU"
2. "All apps"
3. "Device manager"

Icons to the right of the device name indicate for which function the device can be used.

Tap the desired icon to activate a function.

Icon	Meaning
	Telephone.
	Bluetooth audio.
	Apple CarPlay.
	Android Auto.

Configuring the device

Functions can be activated or deactivated on a paired or connected device.

The range of functions depends on the mobile device.

Observe the information on the control display.

1. "MENU"
2. "All apps"
3. "Device manager"
4. Select the required device.
5. Select the desired setting.

Telephone priority

If several mobile phones are connected to the vehicle, it is possible to define priorities for them. The mobile phone with the highest priority is

preferably used, for example for outgoing calls and messages.

1. "MENU"
2. "All apps"
3. "Device manager"
4. "Settings"
5. "Telephone priorities"
6. Select the required device.
7. Move to select the desired priority.

Bluetooth connection

Operating requirements

- ▶ Compatible device with Bluetooth interface. Compatible devices, see page 76.
- ▶ The vehicle key is in the vehicle for the Bluetooth® telephony.
- ▶ The device is operational.
- ▶ Bluetooth is activated on the device and switched on in the vehicle.
- ▶ The control display indicates that the system is ready for pairing.
- ▶ The device may require certain Bluetooth default settings, for example visibility; see the operating instructions of the device.

Connecting a device

1. "MENU"
2. "All apps"
3. "Device manager"
4. "Connect new device"
Mobile phones in range are displayed on the control display.
5. Select the required mobile phone
6. Compare the control number displayed on the control display with the control number in

the display of the mobile phone and confirm that they match.

7. If necessary, select the connection mode: "Use Bluetooth"

The mobile device is connected to the vehicle and displayed in the device list.

Frequently Asked Questions

For the mobile device to work correctly, all conditions need to be met and all the necessary steps need to be carried out in the correct order. Even when this is done, however, there may still be instances where the mobile device does not function as expected.

In such cases, the following explanations may provide assistance:

Why was it not possible to pair or connect the mobile phone?

- ▶ Too many Bluetooth devices are paired to the mobile phone or the vehicle.

In the vehicle, delete Bluetooth connection with other devices.

Delete the Bluetooth connection from the device list on the mobile phone and start a new device search.

Too many Bluetooth devices with the same function are paired.

- ▶ The mobile phone is in power-save mode or the battery is low.

Charge the mobile phone and deactivate power-save mode if necessary.

Why does the mobile phone no longer respond?

- ▶ The applications on the mobile phone are no longer functioning.

Switch the mobile phone off and on again.

- ▶ Ambient temperature too high or too low to operate the mobile phone.

Do not subject the mobile phone to extreme ambient conditions.

Why is it not possible to operate the telephone functions via iDrive?

- ▷ No telephone functions are configured for the mobile phone.

Connect the mobile phone with the telephone function.

Why are no phone book entries, not all entries or incomplete entries being displayed?

- ▷ The transfer of the phone book entries is not yet completed.
- ▷ It's possible that only the phone book entries from the mobile phone or the SIM card have been transferred.
- ▷ It may not be possible to display phone book entries containing special characters.
- ▷ It may not be possible to transfer contacts from social networks.
- ▷ The number of phone book entries to be transferred is too high.
- ▷ The volume of data for a particular contact is too large, for example due to saved information such as memos.
Reduce the data volume for the contact.
- ▷ The mobile phone has only been connected as an audio source.
Configure the mobile phone and connect it to the telephone function.
- ▷ A contact was created in the telephone contact list after the last synchronisation.
Re-synchronise the contacts: "Reload contacts"

How can the telephone connection quality be improved?

- ▷ Adjust the strength of the Bluetooth signal on the mobile phone; the procedure varies depending on the mobile phone.
- ▷ Insert the mobile phone in the wireless charging tray.
- ▷ Adjust the volume of the microphone separately in the sound settings.

If all the points on the list have been reviewed and the desired function cannot be performed, contact the Hotline, a Service Partner of the manufacturer or another qualified Service Partner or a specialist workshop.

Vehicle WiFi

General

The vehicle WiFi can be used for data exchange between mobile devices and the vehicle.

Operating requirements

- ▷ Standby state is switched on.
- ▷ Compatible device with activated WLAN interface.
- ▷ The BMW app is installed on the mobile device.

Activating vehicle WiFi

1. "MENU"
2. "All apps"
3. "Wi-Fi connections"
4. "Settings"
5. Activate WiFi.

Connecting a mobile device

1. "MENU"
2. "All apps"
3. "Wi-Fi connections"
4. "Connect new device"
5. To pair a mobile device to the vehicle WiFi:
 - ▷ Scan the QR code shown in the display.
 - ▷ Enter the displayed login data on the mobile end device.

Personal eSIM

Principle

The Personal eSIM is a digital SIM card that is permanently installed in the vehicle.

The Personal eSIM enables making phone calls or the use of mobile data without having a mobile phone in the vehicle.

General

Depending on the country of registration and service provider, the Personal eSIM may not be available. Information on availability can be found online, on the BMW website or in the BMW app.

The use of the mobile radio aerials in the vehicle improves the call quality and the reception of mobile data.

The Personal eSIM can be used for the following functions:

- ▶ Making a phone call.
- ▶ Using the Internet via a personal hotspot.

It may be necessary to extend a corresponding mobile phone contract for this purpose.

Operating requirements

- ▶ Active ConnectedDrive contract.
- ▶ The service provider supports the function of the Personal eSIM.
- ▶ The Personal eSIM is linked to the desired BMW ID.
- ▶ The BMW ID is entered in the vehicle, driver identification is defined and synchronisation is activated.
- ▶ The Personal eSIM is logged into the vehicle.
- ▶ A mobile phone has been linked for the telephone function.

For further information:

BMW ID, see page [71](#)

Personal eSIM login

Before the Personal eSIM is used in the vehicle, it is necessary to log in with it once.

1. Log in to the vehicle with the desired BMW ID.
2. "MENU"
3. "All apps"
4. "Device manager"
5. "PERSONAL eSIM"
6. Follow the instructions on the control display. If necessary, scan the displayed QR code with a smartphone and start the activation.
7. Follow the instructions on the smartphone and, if applicable, on the control display.

Alternatively, it is also possible to log in with the Personal eSIM once via the BMW app.

Settings

It is, for example, possible to specify if the Personal eSIM will be used as a telephone or as a personal hotspot.

Roaming can be activated or deactivated for use in other countries.

1. "MENU"
2. "All apps"
3. "Device manager"
4. "PERSONAL eSIM"
5. "Settings"
6. Select the desired settings.

Linking a mobile phone to the Personal eSIM

General

By linking the desired mobile phone, its contacts in the vehicle can be used.

Linking a phone

1. "MENU"
2. "All apps"
3. "Device manager"
4. "Personal eSIM"
5. To activate the eSIM telephone function:
"Telephone functions via eSIM"
6. "Link telephone"
7. link the desired phone.

For further information, see the integrated Owner's Handbook or the Owner's Handbook for Navigation, Entertainment, Communication.

Personal hotspot

Principle

Compatible devices with WLAN interface can use the Internet connection with the data volume of the Personal eSIM via the personal hotspot.

General

Up to ten devices can be connected to the personal hotspot simultaneously.

Operating requirements

- ▶ Compatible device with activated WLAN interface.
Compatible devices, see page 76.
- ▶ The Personal eSIM is set up and active.
- ▶ The mobile data setting for the Personal eSIM has been activated.
- ▶ WLAN is activated in the vehicle.
- ▶ Standby state is switched on.

Activating the personal hotspot and connecting the device

1. "MENU"
2. "All apps"

3. "Personal Hotspot"
4. "Connect new device"
5. "Activate internet access"
6. Logging the desired mobile device into the personal hotspot:
 - ▶ Scan the QR code shown in the display.
 - ▶ Enter the displayed login data on the mobile end device.

All devices connected via the hotspot use the data volume of the Personal eSIM.

Activating/deactivating Internet usage

Internet usage may be deactivated if the data volume is used up, for example.

1. "MENU"
2. "All apps"
3. "Personal Hotspot"
4. "Settings"
5. "Internet access for mobile devices"
6. Select the desired setting.

Apple CarPlay® preparation

Principle

CarPlay enables selected functions of a compatible Apple iPhone to be operated by Siri voice control and iDrive.

Operating requirements

- ▶ Compatible iPhone, iPhone 5 or later with iOS 7.1 or later.
Compatible devices, see page 76.
- ▶ Appropriate mobile radio contract.
- ▶ Bluetooth, WLAN and Siri voice control are activated on the iPhone.
- ▶ The setting for mobile data may need to be activated on the iPhone.
- ▶ WLAN and Bluetooth are activated in the vehicle.

Pairing the iPhone with CarPlay

1. "MENU"
2. "All apps"
3. "Device manager"
4. "Connect new device"

Mobile phones in range are displayed on the control display.
5. Select the desired mobile phone on the control display or the Bluetooth® name of the vehicle on the display of the mobile phone.
6. Compare the control number displayed on the control display with the control number in the display of the mobile phone and confirm that they match.
7. Select CarPlay as the connection mode:

"Use Apple CarPlay"
8. Confirm the connection mode on the display of the smartphone.

The iPhone is connected to the vehicle and displayed in the device list.

Operation

For further information, see the integrated Owner's Handbook or the Owner's Handbook for Navigation, Entertainment, Communication.

Frequently Asked Questions

For the mobile device to work correctly, all conditions need to be met and all the necessary steps need to be carried out in the correct order. Even when this is done, however, there may still be instances where the mobile device does not function as expected.

In such cases, the following explanations may provide assistance:

The iPhone has already been paired with Apple CarPlay. When a new connection setup is established, CarPlay can no longer be selected.

- ▷ Change the connection type of the already connected device, for example using as telephone.
- ▷ Delete the iPhone concerned from the device list.
- ▷ On the iPhone, delete the vehicle concerned from the list of saved connections under Bluetooth and under WLAN.
- ▷ Pair the iPhone as a new device.

If the steps listed have been carried out and the desired function still cannot be performed: contact the hotline, a Service Partner of the manufacturer, another qualified Service Partner or a specialist workshop.

Android Auto® preparation

Principle

Android Auto enables selected functions of a compatible smartphone to be operated by Google Assistant voice control and iDrive.

Operating requirements

- ▷ Compatible Android smartphone: Samsung or Google smartphone with Android 10 or an Android smartphone with Android 11, regardless of the manufacturer.
- ▷ Compatible devices, see page 76.
- ▷ Appropriate mobile radio contract.
- ▷ Bluetooth and WLAN are activated on the smartphone.
- ▷ The smartphone must support a 5 Ghz WiFi connection.
- ▷ The setting for mobile data may need to be activated on the smartphone.
- ▷ WLAN and Bluetooth are activated in the vehicle.

Pairing the smartphone with Android Auto

1. "MENU"
2. "All apps"
3. "Device manager"
4. "Connect new device"

Mobile phones in range are displayed on the control display.

5. Select the required mobile phone.
6. Compare the control number displayed on the control display with the control number in the display of the mobile phone and confirm that they match.
7. Select Android Auto as the connection mode: "Use Android Auto"
8. Confirm the connection mode on the display of the smartphone.

The smartphone is connected to the vehicle and displayed in the device list.

Operation

For further information, see the integrated Owner's Handbook or the Owner's Handbook for Navigation, Entertainment, Communication.

Frequently Asked Questions

For the mobile device to work correctly, all conditions need to be met and all the necessary steps need to be carried out in the correct order. Even when this is done, however, there may still be instances where the mobile device does not function as expected.

In such cases, the following explanations may provide assistance:

The smartphone has already been paired with Android Auto. When a new connection setup is established, Android Auto can no longer be selected.

- ▶ Delete the smartphone concerned from the device list.
- ▶ On the smartphone, delete the vehicle concerned from the list of saved connections under Bluetooth and under WLAN.
- ▶ Pair the smartphone as a new device.

If the steps listed have been carried out and the desired function still cannot be performed: contact the hotline, a Service Partner of the manufacturer, another qualified Service Partner or a specialist workshop.

USB connection

Principle

USB ports with data transfer can be used to play music files.

General

The following mobile devices can be connected to the USB port with data transfer:

- ▶ Mobile phones.
- ▶ Audio devices.
- ▶ USB storage devices.

Common file systems are supported. Formats FAT32 and exFAT are recommended.

A connected USB device is charged via the USB port if the device supports this. Pay attention to the maximum charge current of the USB port.

For further information:

USB port, see page [284](#).

Operating requirements

Compatible device with USB port.

For further information:

Compatible devices, see page [76](#).

Connecting a device

Connect the USB device to a USB port using a suitable adapter cable.

When connecting, bear the following in mind:

- ▶ Do not use force when inserting the connector into the USB port.
- ▶ Use a flexible adapter cable.
- ▶ Protect the USB device from mechanical damage.
- ▶ Due to the large variety of USB devices available on the market, it is not possible to guarantee that every device can be operated via the vehicle.
- ▶ Do not expose the USB devices to extreme environmental conditions, for example very high temperatures; see the operating instructions of the device.
- ▶ Due to the large variety of different compression techniques, correct playback of the media stored on the USB device cannot be guaranteed in every case.
- ▶ To ensure correct transmission of the stored data, do not charge a USB device from the 12 V power socket in the vehicle when the device is also connected to the USB port.
- ▶ Depending on how the USB device is being used, settings may need to be performed on the USB device; see the operating instructions of the device.

The connected USB device is displayed on the control display in the MEDIA menu.

Unsuitable USB devices

- ▶ USB hard drives.
- ▶ USB hubs.
- ▶ USB memory card readers with several slots.
- ▶ HFS-formatted USB devices.
- ▶ Devices such as fans or lamps.

Opening and closing

Vehicle equipment

This chapter describes equipment, systems and functions which are offered or will be offered on a model-specific basis, even if they are not included in the vehicle in question.

For further information:

Vehicle equipment, see page 7.

Vehicle key

General

The delivery specification includes two vehicle keys, each containing an integrated key.

Each vehicle key contains a replaceable battery.

Various settings are possible for the button functions, depending on the equipment and the national-market version.

A BMW ID or a driver profile with personal settings can be assigned to a vehicle key.

To provide information on maintenance requirement, the service data is saved in the vehicle key.

To prevent the vehicle key from being locked in, take it with you whenever you leave the vehicle.

Safety note

WARNING





The vehicle key has a button cell battery. Batteries or button cells can be swallowed and lead to serious or fatal injuries within two hours, for example due to internal burns or chemical burns. There is a danger of injury or danger to life. Keep the vehicle key and batteries out of reach of children. Immediately seek medical help if there is any suspicion that a battery or

button cell has been swallowed or is located in any part of the body.

Overview



Buttons on the vehicle key.

Icon	Meaning
	Unlock.
	Lock.
	Open/close the luggage compartment.
	Function adjustable: Home lights, see page 179. Pre-conditioning, see page 280.

Additional vehicle keys

Additional vehicle keys are available from a Service Partner of the manufacturer or another qualified Service Partner or a specialist workshop.

Loss of vehicle keys

A lost vehicle key can be disabled and replaced by a Service Partner of the manufacturer or another qualified Service Partner or a specialist workshop.

If a BMW ID or driver profile has been assigned to the lost vehicle key, the connection to this vehicle key must be deleted. A new vehicle key can then be assigned to the BMW ID or driver profile.

Replacing the battery

NOTE

Improper batteries in the vehicle key can damage the vehicle key. There is a risk of material damage. Always replace the discharged battery with a battery with the same voltage, the same size and the same specification.

1. Remove the integrated key from the vehicle key.
2. Position the integrated key under the battery compartment lid, arrow 1, and pry off the lid with a lever movement of the integrated key, arrow 2.

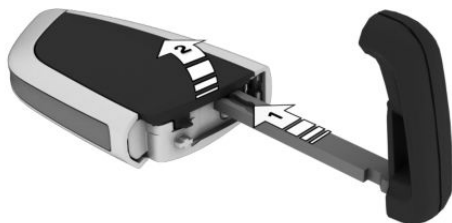

3. Use a pointed object to press the battery in the direction of the arrow and lift it out.

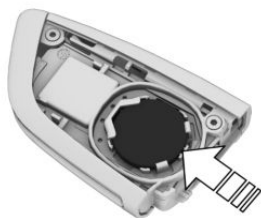

4. Insert a type CR 2032 3 V battery with the positive side facing up.

5. Press the cover back into position and close it.
6. Insert the integrated key into the vehicle key until the integrated key engages.



Dispose of old batteries at a Service Partner of the manufacturer or another qualified Service Partner or a specialist workshop or hand them in to an authorised collecting point.

Integrated key

General

With the integrated key, the driver's door can be unlocked without the vehicle key.

Depending on the national-market version, the integrated key fits the glove compartment.

Depending on the model and equipment, the key switch for the front passenger airbag can be operated with the integrated key.

Safety note

WARNING

On some national-market versions, unlocking from the inside is only possible with special knowledge.

There is a risk of injury or danger to life if persons remain in the vehicle for extended periods and are exposed to extreme temperatures as a result. Do not lock the vehicle from the outside when there is someone inside it.

Removing the integrated key

1. Press the button, arrow 1, and pull out the integrated key, arrow 2.



2. Pull off frame from integrated key.

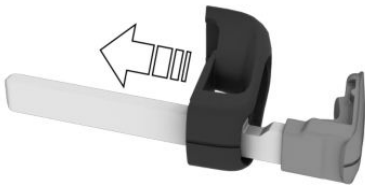

Unlocking via the door lock

1. Pull the door handle outwards with one hand and hold it.

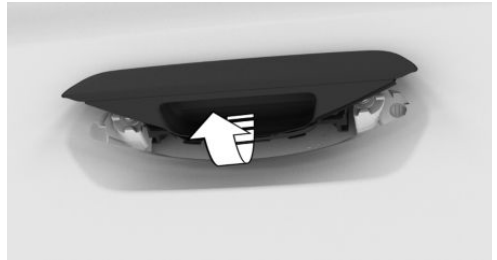

2. Unlock the door lock by turning it anti-clockwise using the integrated key.



The other doors must be unlocked using the central locking system button or manually from the inside.

Locking the vehicle from the interior

General

The vehicle can be locked manually from the inside.

To avoid locking the vehicle key in the vehicle, do not place the vehicle key into the vehicle.

Overview

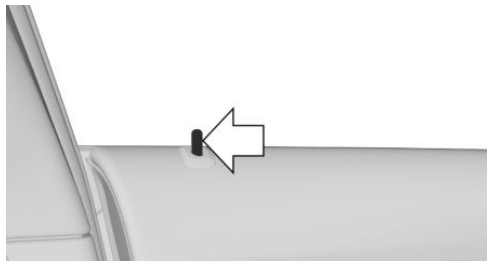

Door pin for manual locking of the driver's door.

Locking the vehicle

1. Close the driver's door.
2. Press the door pin in the driver's door down from the inside.
3. Lock rear doors from the inside.
4. Open the front passenger door and lock it manually.
5. Close the front passenger door from the outside.

Alarm system

The activated alarm system is triggered when the door is opened after being unlocked via the door lock.

The alarm system is not switched on if the vehicle is locked with the integrated key.

Emergency detection of the vehicle key

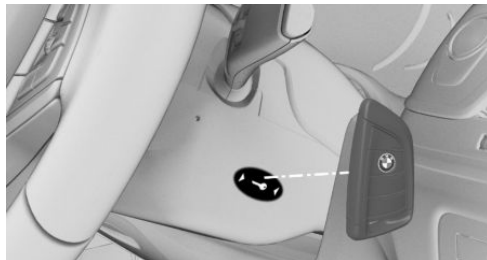

Drive-ready state cannot be switched on if the vehicle key has not been detected.

If this happens, proceed as follows:

1. Hold the rear side of the vehicle key against the mark on the steering column. Pay attention to the display in the instrument cluster.
2. ▷ If the vehicle key is detected:
Switch on drive-ready state within 10 seconds.
- ▷ If the vehicle key is not detected:
Slightly change the position of the vehicle key and repeat the procedure.

Malfunction

A Check Control message is shown where applicable.

It may be difficult for the vehicle to detect the vehicle key in some conditions, including the following:

- ▷ The battery of the vehicle key is discharged.
- ▷ Disruption of the radio link by transmission masts or other equipment transmitting powerful signals.
- ▷ Shielding of the vehicle key by metallic objects.

Do not transport the vehicle key together with metallic objects.

- ▷ Disruption of the radio link by mobile phones or other electronic devices in the immediate vicinity of the vehicle key.

Do not transport the vehicle key together with electronic devices.

- ▷ Interference with the radio transmission caused by the charging process of mobile devices, for example a mobile phone.
- ▷ The vehicle key is located in the immediate vicinity of the wireless charging tray.

Place the vehicle key somewhere else.

- ▷ Radio link fault while the vehicle is charging.

If there is a malfunction, the vehicle can be unlocked and locked from the outside with the integrated key. Use the emergency detection of the vehicle key to turn on the drive-ready state.

Access to vehicle interior

Safety notes

WARNING

Persons remaining in the vehicle or pets left inside can lock the doors from the inside and lock themselves in. In this case, the vehicle cannot be opened from the outside. There is a danger of injury. Carry the vehicle key with you so that you can open the vehicle from the outside.

WARNING

On some national-market versions, unlocking from the inside is only possible with special knowledge.

There is a risk of injury or danger to life if persons remain in the vehicle for extended periods and are exposed to extreme temperatures as a result. Do not lock the vehicle from the outside when there is someone inside it.

WARNING

Unsupervised children or pets in the vehicle can set the vehicle in motion and endanger themselves or other road users, for example by the following actions:

- ▷ Pressing the Start/Stop button.
- ▷ Releasing the parking brake.
- ▷ Opening and closing doors or windows.
- ▷ Engaging selector lever position N.
- ▷ Operating vehicle equipment.

There is a risk of accident or injury. Do not leave children or pets unsupervised in the vehicle. When leaving the vehicle, take the vehicle key with you and lock the vehicle.

Actions during unlocking

The behaviour of the vehicle during unlocking depends on the following settings:

- ▷ Only the driver's door and the charging socket flap will be unlocked or all access to the vehicle will be unlocked.
- ▷ The unlocking of the vehicle can be confirmed with a light signal or a sound signal.
- ▷ The welcome light can be turned on when the vehicle is being unlocked.
- ▷ After opening a vehicle door, the window can be lowered more to make it easier to enter the vehicle.

The following functions are also carried out:

- ▷ If a BMW ID or driver profile was assigned to the vehicle key, this BMW ID or driver profile will be activated.
- ▷ The interior lights are switched on unless they were switched off manually.
- ▷ Depending on the equipment, folded exterior mirrors are folded out.
If the exterior mirrors were folded in using the button inside the vehicle, they are not folded out when the vehicle is unlocked.
- ▷ The anti-theft security system is switched off.
- ▷ The alarm system is switched off.

For further information:

- ▷ For settings, see page 100.
- ▷ Welcome light, see page 179.
- ▷ BMW ID/driver profiles, see page 71.

Actions during locking

The behaviour of the vehicle during locking depends on the following settings:

- ▷ The locking of the vehicle can be confirmed with a light signal or a sound signal.
- ▷ Depending on the equipment, the exterior mirrors can be folded in automatically during locking. If the hazard warning lights are

switched on, the exterior mirrors are not folded in.

- ▶ Home lights can be activated during locking.

The following functions are carried out:

- ▶ All the doors, the tailgate and the charging socket flap are locked.
- ▶ The anti-theft security system is switched on. This prevents the doors from being unlocked using the locking buttons or the door handles.
- ▶ The alarm system is switched on.

If drive-ready state is still switched on when locking, the vehicle horn sounds twice. If this happens, switch off drive-ready state using Start/Stop button.

For further information:

For settings, see page 100.

With the vehicle key

Unlocking the vehicle



Press the button on the vehicle key.

If only the driver's door and the charging socket flap have been unlocked in accordance with the settings, press the button on the vehicle key again to unlock the other vehicle access points.

The vehicle is operational after one of the front doors is opened.

The lighting functions may depend on the ambient brightness.

Comfort entry



Press the button on the vehicle key twice in immediate succession to activate comfort entry.

Depending on the settings, the window is lowered further when a door is opened.

Locking the vehicle

1. Close the driver's door.



2. Press the button on the vehicle key.

On the outside door handle

Principle

This feature allows you to access the vehicle without having to use the vehicle key.

The vehicle key is automatically detected near the vehicle.

General

The function is available with Comfort Access.

Operating requirements

- ▶ Carry the vehicle key with you, for example, in your pants pocket.
- ▶ To lock the vehicle, the vehicle key must be located outside the vehicle in the vicinity of the doors.
- ▶ After locking, approx. 2 seconds must elapse before unlocking is possible.

Unlocking the vehicle

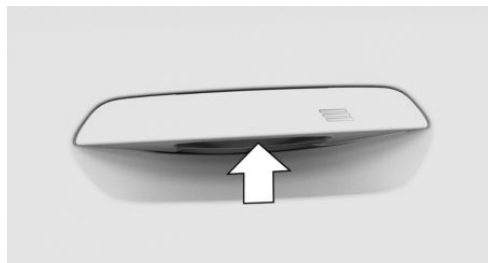

Reach into the handle recess of a vehicle door.

Locking the vehicle

1. Close the driver's door.
2. Touch the grooved surface on the outside door handle of a closed front door with your

finger for approx. 1 second without reaching into the handle recess.

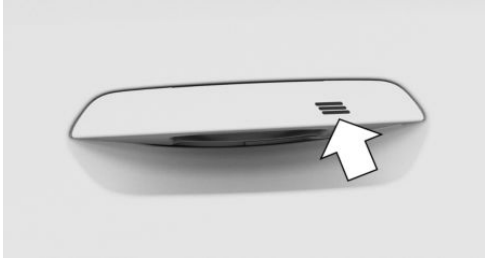

Malfunction

Wet or snowy conditions may disrupt the locking request detection on the outside door handles.

If a fault occurs, unlock and lock the vehicle with the buttons on the vehicle key or with the integrated key.

Touchless unlocking/locking of the vehicle

Principle

The vehicle is unlocked when the driver approaches the locked vehicle with the vehicle key. If the driver moves away from the unlocked vehicle with the vehicle key, the vehicle is locked.

General

The function is available with Comfort Access.

The vehicle is unlocked when an authorised vehicle key is detected in the unlocking zone.

The unlocking zone is located within a radius of approx. 1 m, 3 ft around the side and rear of the vehicle.

The vehicle is locked when the vehicle key leaves the locking zone.

The locking zone is located within a radius of approx. 2 m, 6 ft around the side and rear of the vehicle.

If the vehicle key remains within the unlocking zone without moving for a prolonged period of time, the vehicle is locked automatically.

If a person is detected on the front passenger seat during locking and if the front passenger's seat belt is in the seat belt buckle during locking:

- ▶ The vehicle is locked, but not protected against theft.
- ▶ The charging socket flap remains unlocked.

Actions during unlocking

If the settings specify that only the driver's door and the charging socket flap will be unlocked, note the following:

The driver's door and the charging socket flap will only be unlocked when the driver approaches the vehicle on the driver's side.

For further information:

For settings, see page 100.

Operating requirements

- ▶ Carry the vehicle key with you, for example, in your pants pocket.
- ▶ Automatic unlocking and locking must be activated in the settings.
- ▶ Drive-ready state must be switched off.
- ▶ To lock the vehicle contactlessly, there must not be a second vehicle key within a radius of six metres of the vehicle.
- ▶ If the vehicle has been in rest state for several days, contactless unlocking/locking is not possible until the vehicle has been driven.

For further information:

For settings, see page 100.

With the Key Card

Principle

The Key Card is a chip card on which a digital key is installed. It can be used to unlock and lock the vehicle.

For further information:

Key Card, see page 95.

General

The Key Card is available with Comfort Access.

Locking/unlocking the vehicle

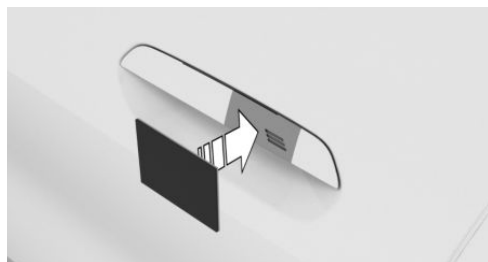

Hold the activated Key Card directly and centrally up against the outside door handle on the driver's door.

When locking the vehicle with the Key Card, make sure that all doors and the luggage compartment are closed.

If the Key Card is not detected, slightly change the position of the Key Card and repeat the procedure.

With the BMW Digital Key

Principle

Depending on the national-market version and equipment, a digital key can be installed on a compatible smartphone and used to unlock and lock the vehicle.

For further information:

BMW Digital Key, see page 96.

Locking/unlocking the vehicle

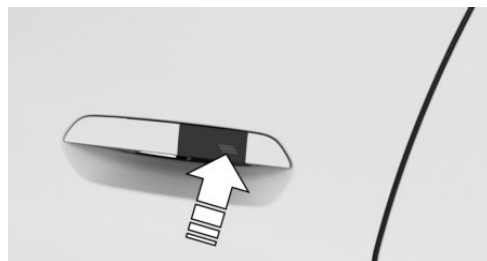

Hold the NFC antenna on the smartphone directly and centrally up against the outside door handle on the driver's door. The position of the NFC antenna will depend on the smartphone model.

When locking the vehicle with the smartphone, make sure that all doors and the luggage compartment are closed.

Frequently Asked Questions

What measures can be taken to enable a vehicle to be opened if the vehicle key has accidentally been locked inside the vehicle?

- ▶ The Remote Services of the BMW app can be used to lock and unlock a vehicle. This requires an active BMW ConnectedDrive contract and the BMW app must be installed on a smartphone.
- ▶ Unlocking of the vehicle can be requested via the BMW ConnectedDrive call centre. This requires an active BMW ConnectedDrive contract.

Access to the luggage compartment

General

The luggage compartment will be opened to the configured opening height.

Safety notes

WARNING

Parts of the body can become trapped when the tailgate is operated. There is a danger of injury. When opening and closing, make sure that the area of movement of the tailgate is kept clear.

WARNING

The tailgate swings outwards when opened. There is a risk of injury or material damage. When opening and closing, make sure that the area of movement of the tailgate is kept clear.

NOTE

Pointed or angular objects can strike the windows and the heating conductors during the journey. There is a risk of material damage. Cover edges and make sure that pointed objects cannot strike the windows.

With the vehicle key

General

To prevent the vehicle key from being locked in, do not place it in the luggage compartment.

Depending on the equipment and national-market versions, it is possible to select whether the doors are also unlocked when unlocking with the vehicle key.

Functional prerequisites

To open the luggage compartment with the vehicle key, the trailer socket must not be occupied.

Selector lever position P must be engaged to open the luggage compartment with the vehicle key.

Opening the luggage compartment



Press the button on the vehicle key for approximately 1 second.

Closing the luggage compartment



Hold down the button on the vehicle key until luggage compartment is closed.

Releasing the button stops the movement.

If the doors were not unlocked, the luggage compartment is locked again as soon as it closes.

On the luggage compartment

General

With Comfort Access, the luggage compartment can be accessed without activating the vehicle key.

Simply having the vehicle key with you, for example in your trouser pocket, is sufficient.

The key is automatically detected near the vehicle.

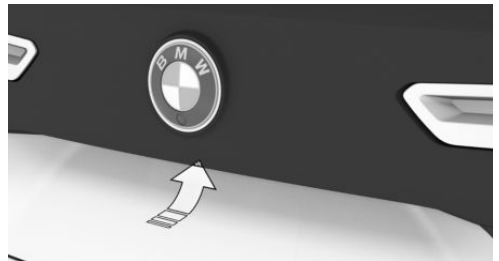

Opening the luggage compartment



- ▶ Unlock the vehicle and then press the button on the luggage compartment.
- ▶ With Comfort Access: carry the vehicle key with you and press the button on the luggage compartment.
Locked doors are not unlocked.

Closing the luggage compartment



- ▶  Press the button on the luggage compartment.
- ▶  Press the button on the luggage compartment.
The vehicle is locked after the luggage compartment has been closed. For this to happen, the driver's door must be closed and the vehicle key must be outside the vehicle in the vicinity of the luggage compartment.

In the interior

Operating requirements

In order to be able to open the luggage compartment with the button in the vehicle interior, the trailer socket must not be occupied.

Opening the luggage compartment

- ▶  Press the button in the driver's door storage compartment.

Closing the luggage compartment

- ▶  Pull and hold the button in the driver's door storage compartment.

The vehicle key or the digital key must be located in the vehicle interior for this function.

Cancelling the opening procedure

The opening procedure is interrupted in the following situations:

- ▶ If the vehicle begins to move.
- ▶ By pressing the button on the outside of the luggage compartment. Pressing it again closes the luggage compartment again.
- ▶ By pressing the button on the inside of the luggage compartment. Pressing it again closes the luggage compartment again.
- ▶ By pressing the button on the vehicle key. Pressing again resumes the opening procedure.
Pressing and holding the button will close the luggage compartment again.
- ▶ By pressing or pulling the button in the driver's door. Pressing again resumes the opening procedure.

Cancelling the closing operation

The closing operation is interrupted in the following situations:

- ▶ When driving off suddenly.
- ▶ By pressing the button on the outside of the luggage compartment. Pressing it again opens the luggage compartment again.
- ▶ By pressing the button on the inside of the luggage compartment. Pressing it again opens the luggage compartment again.
- ▶ By releasing the button in the driver's door. Pulling and holding the button again resumes the closing operation.
- ▶ By releasing the button on the vehicle key. Pressing and holding it again resumes the closing operation.

Touchless opening and closing of the luggage compartment

Principle

Touchless opening and closing of the luggage compartment is possible when carrying the vehicle key on your person.

Two sensors detect a forward-directed foot movement in the central rear area and the luggage compartment is opened and closed.

General

The function is available with Comfort Access. If the vehicle key is within the sensor range, the luggage compartment may open or close inadvertently if you unintentionally move your foot or if a foot movement is detected.

The sensor range extends to approximately 1.50 m, 5 ft behind the rear area.

If you open the luggage compartment with no-touch activation, locked doors will not be unlocked.

Safety notes

WARNING

Parts of the body can become trapped when the tailgate is operated. There is a danger of injury. When opening and closing, make sure that the area of movement of the tailgate is kept clear.

WARNING

The tailgate swings outwards when opened. There is a risk of injury or material damage. When opening and closing, make sure that the area of movement of the tailgate is kept clear.

NOTE

Pointed or angular objects can strike the windows and the heating conductors during the journey. There is a risk of material damage. Cover edges and make sure that pointed objects cannot strike the windows.

Operating requirements

- ▶ To enable the touchless opening of the luggage compartment, the trailer socket must not be occupied.
- ▶ Selector lever position P must be engaged for touchless opening of the luggage compartment.
- ▶ Contactless opening and closing of the luggage compartment must be activated in the settings.

For further information:

For settings, see page 100.

Opening the luggage compartment

1. Stand in the centre behind the vehicle, approximately an arm's length away from the rear of the vehicle.
2. Kick your foot as far as possible underneath the vehicle and immediately pull it back. Your leg must move across the ranges of both sensors.



Before the luggage compartment opens, the hazard warning lights will flash.

Moving the foot again will stop the opening procedure. The subsequent foot movement will close the luggage compartment again.

Closing the luggage compartment

Perform the foot movement for opening the luggage compartment.

The hazard warning lights flash and an acoustic signal sounds.

Moving the foot again will stop the closing operation. The subsequent foot movement will open the luggage compartment again.

System limits

Detection of foot movement may be restricted by the following external circumstances:

- Ice, snow or slush on the rear of the vehicle.
- Dirt or road salt on the rear of the vehicle.

Movement in the vicinity of the sensors may cause the luggage compartment to open unintentionally, for example if water flows underneath the vehicle during cleaning or in heavy rain. To prevent the luggage compartment from opening unintentionally, make sure that the vehicle key is far enough away from the rear of the vehicle.

Malfunction

In the event of an electrical fault, operate the unlocked luggage compartment manually with a slow and smooth motion.

Luggage compartment emergency release



Pull the handle in the luggage compartment. The luggage compartment is unlocked.

Key Card

Principle

The Key Card can be used to lock, unlock and start the vehicle.

General

The Key Card is available with Comfort Access. Depending on the national-market version, the Key Card may not be available.

A digital key that has already been paired with the vehicle is installed on the Key Card. The digital key must be activated via iDrive.

When you exit the vehicle, deactivate the Key Card or take the Key Card with you, as it can be used to start the vehicle when activated. Always take the vehicle key with you to a service appointment.

Safety note

NOTE

If the Key Card and a mobile device are in the wireless charging tray at the same time, the Key Card could become damaged. There is a risk of material damage. Do not place the Key Card in the wireless charging tray at the same time as a mobile device.

Activating/deactivating the Key Card in the vehicle

General

To activate the Key Card, it must be in the smartphone tray and there must be a vehicle key in the vehicle.

To deactivate the Key Card, there must be a vehicle key in the vehicle.

If BMW Digital Key is activated for the vehicle, a digital key can be used instead of the vehicle key.

A deactivated Key Card will remain in the list of registered digital keys.

Activating the Key Card



1. Open the cover of the smartphone tray.
2. Place the Key Card in the middle of the smartphone tray.
3. Follow instructions on the control display.

Deactivating the Key Card

1. "MENU"
2. "Vehicle apps"
3. "Doors and windows"
4. "Key Card"
5. "Deactivate Key Card"

A deactivated Key Card will remain in the list of registered digital keys.

Unlocking and locking the vehicle

The vehicle can be unlocked and locked with the activated Key Card.

For further information:

Access to the vehicle interior, see page 88.

Switching on drive-ready state



1. Open the cover of the smartphone tray.
2. Place the activated Key Card in the middle of the smartphone tray.
3. Press the Start/Stop button.

After turning on the drive-ready state, the Key Card can be taken out of the storage tray.

Malfuction

Objects between the sensors and the Key Card, for example a purse or wallet, may prevent the vehicle from detecting the Key Card.

BMW Digital Key

Principle

BMW Digital Key allows you to use a compatible smartphone to lock, unlock and start the vehicle.

General

Availability and range of functions of the BMW Digital Key depend on the equipment and national-market version.

BMW Digital Key can be used with a compatible smartphone or other compatible end devices.

To unlock and start a vehicle with a compatible smartphone, this function must be offered by the smartphone manufacturer. The BMW app provides a check to determine if the smartphone and the vehicle are compatible and which functions are supported.

A BMW ID or a driver profile with individual settings can be assigned to a digital key.

When using a smartphone as a digital key, always carry a vehicle key or the activated Key Card with you too. This will mean that you can still access the vehicle even if the smartphone is not working. It is also useful to have the vehicle key or Key Card about your person if the vehicle has to be handed over to another person. The vehicle key or Key Card can then be handed over, instead of the smartphone. Always take the vehicle key with you to a service appointment.

For further information:

- ▶ BMW ID/driver profiles, see page 71.
- ▶ www.bmw.com/digitalkey.

Operating requirements

- ▶ The smartphone is compatible with BMW Digital Key.
- ▶ The vehicle is linked with the ConnectedDrive account of the registered keeper.
- ▶ The smartphone battery is sufficiently charged. The minimum battery charge required depends on the smartphone in question.

Enabling the main digital key

The registered keeper's smartphone is enabled as the main digital key in the vehicle. To do so, the registered keeper must provide proof of authorisation for their vehicle.

Proof of authorisation can be started via the BMW app or the activation code in the corresponding smartphone function, for example in the Wallet app. Both vehicle keys must be in the vehicle during enabling.

Follow the enabling instructions in the Digital Key menu within the BMW app or on the control display.

Sharing digital keys

General

Digital Key enables digital keys to be shared with other people. This option is provided via the smartphone enabled as the main digital key.

Passing on authorisation

To share the digital key, select the corresponding function on the smartphone, for example in the Wallet app.

As soon as a digital key is shared with a person, this person receives an invitation. If the invitation is accepted, the digital key is activated on the recipient's smartphone.

Limiting the range of functions

Certain functions of the digital key can be limited before handing it over. For example, if the digital key is handed over to a novice driver, the switch-off of driving stability control systems may be excluded. For more information, refer to the ConnectedDrive portal and the BMW app.

Authentication

Depending on the recipient's smartphone model, authentication may be required for security reasons.

An authorised vehicle key, the main digital key or another method can be used to perform the authentication. Corresponding information is displayed for your attention on the smartphone or control display.

Deleting digital keys

General

Deleted digital keys are removed from the list of enabled digital keys.

Deleted digital keys cannot be restored.

Deleting the digital master key

The digital master key can be deleted from the smartphone or via iDrive.

The deletion of the digital master key is completed immediately.

Deleting a shared key

Shared keys can be deleted via the smartphone associated with the main digital key, via the smartphone associated with a shared key or in iDrive.

A shared key will only be deleted via the smartphone associated with the main digital key if the vehicle is being used with a key other than the one that is to be deleted.

If the smartphone associated with a shared key or iDrive is used to delete a shared key, it will be deleted immediately.

Deletion in iDrive

To enable a digital key to be deleted in iDrive, there must be an authorised vehicle key in the vehicle or the main key must be in the smartphone tray.

1. "MENU"
2. "Vehicle apps"
3. "Doors and windows"
4. "Digital Key"
5. Select a digital key as necessary.
6. Delete the Digital Key.

Resetting the function

To reset BMW Digital Key function, there must be an authorised vehicle key in the vehicle.

All digital keys, including the main key, are deleted when the BMW Digital Key function is reset.

Following the reset, it will no longer be possible to lock, unlock or start the vehicle with a digital key.

The main digital key must be enabled again in order to be able to use BMW Digital Key again.

1. "MENU"
2. "Vehicle apps"
3. "Doors and windows"
4. "Digital Key"
5. "Reset function"

Unlocking and locking the vehicle

The vehicle can be unlocked and locked using the outside door handle.

For further information:

Access to the vehicle interior, see page 88.

Switching on drive-ready state

Using the smartphone tray

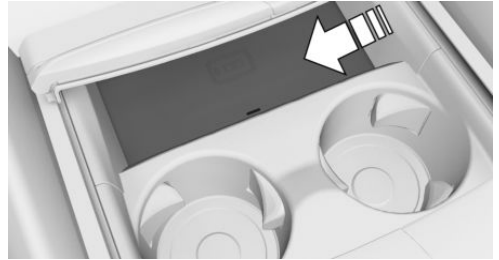

1. Open the cover of the smartphone tray.
2. Place the smartphone in the middle of the smartphone tray.
Make sure that the display is pointing upwards.
3. Close the cover of the smartphone tray.
4. Press the Start/Stop button to turn on the drive-ready state.

Selling the smartphone

Delete all digital keys from the smartphone before selling it. This ensures that the smartphone can no longer be used for the vehicle.

Selling the vehicle

Before selling a vehicle, reset the digital key function or remove the vehicle from the ConnectedDrive account of the current registered keeper.

If the vehicle is removed from the ConnectedDrive account, all digital keys for the vehicle are deleted.

Malfunction

It may be difficult for the vehicle to detect the digital key in some circumstances, including the following:

- ▶ The smartphone is shielded from the sensors in the vehicle by an unsuitable smartphone cover.
- ▶ There are objects between the smartphone and its cover, for example a card with a chip or the Key Card.
- ▶ Fault of the connection from transmission towers or other equipment with high transmitting power.
- ▶ Shielding of the smartphone due to buildings or metal objects.

Central locking buttons

General

The vehicle is automatically locked when moving off.

If an accident of appropriate severity occurs, the vehicle is automatically unlocked. The hazard warning lights and interior lights are switched on.

Overview



Central locking buttons.

Locking the vehicle



Press the button with the front doors closed.

Locking does not activate the vehicle's anti-theft protection system.

Unlocking the vehicle



Press the button.

To open the door

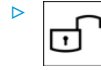

Press the button to unlock all the doors together.

Pull the door handle above the armrest.

- ▶ Pull the door handle on the door being opened. The other doors remain locked.

Parking service mode

Principle

The control display is disabled in parking service mode.

This mode can be used, for example, if the vehicle is to be handed over to a parking service.

General

Depending on the national-market version, the parking service mode may not be available.

In parking service mode, the vehicle settings cannot be changed via iDrive. Settings stored in a BMW ID or a guest profile cannot be changed. Personal data cannot be displayed.

In addition, the following actions are performed:

- ▶ The volume of the audio system is limited.
- ▶ The integrated universal remote control is deactivated.
- ▶ The Dynamic Stability Control cannot be turned off.
- ▶ The availability of certain settings of the drive modes is restricted.

For further information:

BMW ID/driver profiles, see page 71.

Operating requirements

The driver has registered in the vehicle with a BMW ID.

Activating parking service mode

1. "MENU"
2. "Vehicle apps"
3. "System settings"
4. "Valet parking mode"
5. If necessary, "PIN"

If the active BMW ID does not have an assigned PIN, enter this PIN now. The PIN is needed to deactivate the parking service mode.

6. If necessary, enter the PIN.
7. "Activate valet parking mode"

Deactivating parking service mode

1. Select the desired BMW ID on the lock screen.
2. ▶ Enter the assigned PIN for the BMW ID.
If PIN was forgotten: enter access data for the BMW ID.
▶ If the selected BMW ID does not have an assigned PIN: enter access data for the BMW ID.

Settings

General

Various settings are possible for opening and closing, depending on the equipment and the national-market version.

Unlocking and locking

Doors

1. "MENU"
2. "Vehicle apps"

3. "Doors and windows"
4. "Lock/unlock"
5. "Unlock"
6. Select the desired setting:
 - ▶ "Driver's door only"
Only the driver's door and charging socket flap are unlocked. Pressing again unlocks the entire vehicle.
 - ▶ "All doors"
The entire vehicle is unlocked.
 - ▶ "Lower window"
The entire vehicle is unlocked.
Pressing the button on the vehicle key twice in immediate succession causes the window to be lowered further when the door is subsequently opened.

Touchless unlocking/locking

1. "MENU"
2. "Vehicle apps"
3. "Doors and windows"
4. "Comfort access"
5. Select the desired setting:
 - ▶ "Unlock when approaching"
 - ▶ "Lock when walking away"

Automatic unlocking

1. "MENU"
2. "Vehicle apps"
3. "Doors and windows"
4. "Lock/unlock"
5. Select the desired setting:
 - ▶ "Unlock doors at end of journey"
 - ▶ "Unlock doors when in Park"

After drive-ready state has been switched off by pressing the Start/Stop button or by engaging the selector lever position P, the locked vehicle is automatically unlocked.

Automatic locking

1. "MENU"
2. "Vehicle apps"
3. "Doors and windows"
4. "Lock/unlock"
5. "Lock after a short time"

The vehicle is automatically locked again after a short while if no doors are opened after unlocking.

Vehicle acknowledgement signals

1. "MENU"
2. "Vehicle apps"
3. "Doors and windows"
4. "Lock/unlock"
5. To deactivate or activate desired acknowledgement signals:
 - ▷ "Flash on lock/unlock"

Unlocking is acknowledged by two flashes, locking by one flash.
 - ▷ With alarm system:

"Sound on lock/unlock"

Unlocking is acknowledged by two acoustic signals, locking by one acoustic signal.

Automatic folding of the mirrors

1. "MENU"
2. "Vehicle apps"
3. "Doors and windows"
4. "Lock/unlock"
5. "Fold mirrors on lock/unlock"

Luggage compartment

Luggage compartment and doors

You can set up if only the luggage compartment will be unlocked or if the doors will also be un-

locked when the luggage compartment is unlocked.

1. "MENU"
2. "Vehicle apps"
3. "Doors and windows"
4. "Tailgate"
5. Select the desired setting:
 - ▷ "Tailgate"

Depending on the equipment, the luggage compartment will be unlocked or opened.
 - ▷ "Tailgate and door(s)"

Depending on the equipment, the luggage compartment will be unlocked or opened and the doors are unlocked.
 - ▷ "Tailgate will only open if vehicle is already unlocked"

The vehicle must be unlocked before the tailgate can be operated with the vehicle key.
 - ▷ "Lock tailgate button"

Operation of the tailgate with the vehicle key is disabled.

Adjusting the opening height

It is possible to specify how far the tailgate should open.

When setting the opening height, make sure that there is a clearance of at least 10 cm, 4 in above the tailgate.

1. "MENU"
2. "Vehicle apps"
3. "Doors and windows"
4. "Tailgate"
5. "Opening height"
6. Watch the tailgate and set the desired opening height.

Opening/closing the luggage compartment with no-touch activation

1. "MENU"
2. "Vehicle apps"
3. "Doors and windows"
4. "Tailgate"
5. Select the desired setting:
 - ▷ "Open with foot movement"
 - ▷ "Close with foot movement"

Alarm system

Principle

The alarm system visually and acoustically signals when someone attempts to open the locked vehicle.

General

The alarm system responds to the following changes in a locked vehicle:

- ▷ Opening a door, the bonnet or the luggage compartment.
- ▷ Movements inside the vehicle interior.
- ▷ A change in the vehicle's angle of inclination, for instance if an attempt is made to jack it up and steal the wheels or to raise it prior to towing away.
- ▷ An interruption in the battery voltage.
- ▷ Improper use of the OBD diagnostic socket.
- ▷ Locking of the vehicle while a device is connected to the OBD diagnostic socket.

The alarm system indicates these changes visually and audibly:

- ▷ Acoustic alarm:

Depending on local regulations, the acoustic alarm may be suppressed.
- ▷ Optical alarm:

By flashing of the hazard warning lights and, if applicable, the headlights.

To safeguard operation of the alarm system, do not modify the system.

Turning the alarm system on/off

The alarm system is turned off or on as soon as the vehicle is unlocked or locked.

Opening the doors when the alarm system is switched on

The alarm system is triggered when a door is opened if it has been unlocked via the door lock using the integrated key.

Opening the luggage compartment with the alarm system turned on

The luggage compartment can be opened even when the alarm system is turned on.

After closing the luggage compartment, the luggage compartment will be locked and monitored again. The hazard warning lights flash once during closing.

Indicator light on the interior mirror



- ▷ Indicator light flashes every 2 seconds:

The alarm system is switched on.
- ▷ Indicator light flashes for approximately 10 seconds then switches to flashing every 2 seconds:

The interior movement detector and tilt alarm sensor are not active because the doors, bonnet or tailgate are not closed correctly. Correctly closed access points are secured.

Once the remaining open access points have been closed, the interior movement detector and tilt alarm sensor are switched on.

- ▶ The indicator light extinguishes after the vehicle has been unlocked:

This means that the vehicle is not being tampered with.

- ▶ The indicator light flashes after unlocking until drive-ready state is switched on, but for no longer than approximately 5 minutes:

The alarm has been triggered.

Tilt alarm sensor

The vehicle's angle of inclination is monitored.

The alarm system responds, for example when there is an attempt to steal a wheel or tow the vehicle away.

Interior movement detector

The vehicle interior is monitored.

The alarm system responds when movement is detected in the vehicle interior.

To ensure perfect functioning, the windows must be closed.

Avoiding false warnings

General

The tilt alarm sensor and the interior movement detector may trigger an alarm even though no unauthorised activity is taking place.

Situations where false warnings may occur:

- ▶ In washing bays or car washes.
- ▶ In two-level garages.
- ▶ When transporting the vehicle via motorail, car ferry or trailer.
- ▶ When there are pets in the vehicle.

The tilt alarm sensor and interior movement detector can be switched off for such situations.

Switching off the tilt alarm sensor and interior movement detector



Within 10 seconds of locking the vehicle, press the button on the vehicle key.

The indicator light illuminates for approximately 2 seconds and then flashes again.

The tilt alarm sensor and the interior movement detector are switched off until the next time the vehicle is locked.

Ending the alarm

Unlock the vehicle.

If the vehicle is unlocked with the integrated key, the drive-ready state must subsequently be turned on via the emergency detection of the vehicle key.

Window

General

If a window is often opened at the same place, this task can be carried out by the BMW Intelligent Personal Assistant. For example, if you often use the same multi-storey car park.

For further information:

BMW Intelligent Personal Assistant, see page 61.

Safety note

WARNING

Parts of the body can become trapped when the windows are operated. There is a risk of injury or material damage. When opening and closing, make sure that the area of movement of the windows is kept clear.

With the vehicle key

Opening windows



Keep the button on the vehicle key pressed after unlocking.

The windows open for as long as the button on the vehicle key remains pressed.

Close windows



Keep the button on the vehicle key pressed after locking.

The windows close for as long as the button on the vehicle key remains pressed.

Depending on the equipment, the exterior mirrors are folded in provided that they were not folded in when the vehicle was locked. If the hazard warning lights are switched on, the exterior mirrors are not folded in.

On the outside door handle

Principle

The windows can be closed via the outside door handle without operating the vehicle key.

The vehicle key is automatically detected near the vehicle.

General

The function is available with Comfort Access.

Functional prerequisite

Carry the vehicle key with you, for example, in your trouser pocket.

Close windows

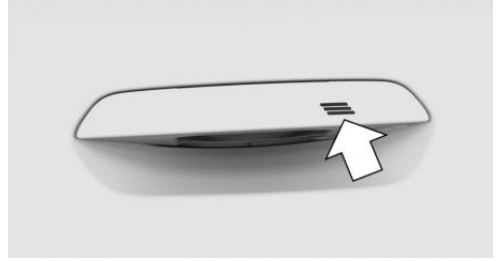

Touch the grooved surface on the outside door handle of a closed vehicle door with your finger and hold it there without grasping the handle recess.

In addition to locking, the windows and the glass sunroof with sun protection are closed.

Depending on the equipment, the exterior mirrors are folded in provided that they were not folded in when the vehicle was locked. If the hazard warning lights are switched on, the exterior mirrors are not folded in.

In the interior

Overview



Electric windows



Operating requirements

The windows can be operated under the following conditions.



- ▶ Standby state is switched on.
- ▶ Drive-ready state is switched on.
- ▶ For a short while after rest state has been established.

The vehicle key or a digital key must be inside of the vehicle.

Opening windows

- ▶  Press the switch as far as the resistance point.
The window opens for as long as the switch is held.
- ▶  Press the switch past the resistance point.
The window is opened automatically.
Pressing the switch again stops the movement.

Close windows

- ▶  Pull the switch as far as the resistance point.
The window closes for as long as the switch is held.
- ▶  Pull the switch past the resistance point.
The window closes automatically.
Pulling the switch again stops the movement.

Anti-trap mechanism

Principle

The anti-trap mechanism prevents objects or parts of the body from becoming trapped between the door frame and window while a window is being closed.

General

If resistance or an obstruction is detected while a window is being closed, the closing operation is interrupted.



Safety note

WARNING

Accessories on the windows, for example aerials, can impair the anti-trap mechanism. There is a danger of injury. Do not attach any accessories within the area of movement of the windows.

Closing with no anti-trap mechanism

If an external hazard or ice prevents you from closing the windows normally, proceed as follows:

1.  Pull the switch past the resistance point and hold it in this position.
The window is closed but with restricted anti-trap mechanism. If the closing force exceeds a certain level, the closing operation is interrupted.
2.  Pull the switch past the resistance point again within approximately 4 seconds and hold it in this position.
The window is closed with no anti-trap mechanism.

Safety switch

Principle

The safety switch can be used to prevent children from opening and closing the rear windows with the switches in the rear, for example.

If an accident of appropriate severity occurs, the safety function is automatically switched off.

Overview



Safety switch

Turning the safety functions on/off



Press the button.

The LED is illuminated when the safety function is switched on.

Glass sunroof

Safety note

WARNING

Parts of the body may become trapped when the glass sunroof is operated. There is a danger of injury. When opening and closing, make sure that the area of movement of the glass sunroof is kept clear.

With the vehicle key

Opening the glass sunroof



Keep the button on the vehicle key pressed after unlocking.

The electric glass sunroof with sun protection is opened for as long as the button on the vehicle key is pressed.

Closing the glass sunroof



Keep the button on the vehicle key pressed after locking.

The electric glass sunroof with sun protection is closed for as long as the button on the vehicle key is pressed.

Depending on the equipment, the exterior mirrors are folded in provided that they were not folded in when the vehicle was locked. If the hazard warning lights are switched on, the exterior mirrors are not folded in.

Via the outside door handle

Principle

The glass sunroof can be closed with the outside door handle without operating the vehicle key.

The vehicle key is automatically detected near the vehicle.

General

The function is available with Comfort Access.

Functional prerequisite

Carry the vehicle key with you, for example, in your trouser pocket.

Closing the glass sunroof

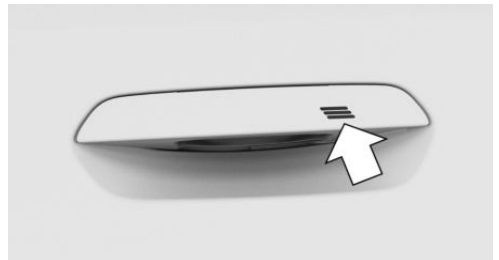

Touch the grooved surface on the handle of a closed vehicle door with your finger and hold it there without grasping the handle recess.

In addition to locking, the windows and the glass sunroof with sun protection are closed.

Depending on the equipment, the exterior mirrors are folded in provided that they were not folded in when the vehicle was locked. If the hazard warning lights are switched on, the exterior mirrors are not folded in.

In the interior

General

The glass sunroof and the sun protection are operated using the same switch.

Overview

Button in the vehicle

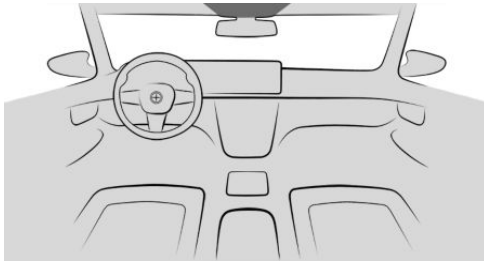

To open/close the glass sunroof/sun protection.

Operating requirements

The glass sunroof can be operated under the following conditions.

- ▶ Standby state is switched on.
- ▶ Drive-ready state is switched on.
- ▶ For a short while after rest state has been established.

The vehicle key must be in the vehicle interior.

Raising/closing the glass sunroof



Press the switch briefly up.

- ▶ The closed glass sunroof is raised and the sun protection opens slightly.
- ▶ The opened glass sunroof closes to the raised position. The sun protection does not move.

- ▶ The raised glass sunroof is closed.

Opening/closing the glass sunroof and sun protection separately

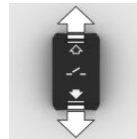

- ▶ Slide the switch backwards as far as the resistance point and hold.

The sun protection opens for as long as the switch is pressed. If the sun protection is already fully open, the glass sunroof is opened.

- ▶ Slide the switch forwards as far as the resistance point and hold.

The glass sunroof closes for as long as the switch is held. If the glass sunroof is already closed or is in the raised position, the sun protection is closed.

- ▶ Slide the switch backwards beyond the resistance point.

The sun protection is opened automatically. If the sun protection is already fully open, the glass sunroof is opened automatically.

Pressing the switch again stops the movement.

- ▶ Slide the switch forwards beyond the resistance point.

The glass sunroof is closed automatically. If the glass sunroof is already closed or is in the raised position, the sun protection is closed automatically.

Pressing the switch again stops the movement.

Opening/closing the glass sunroof and sun protection together

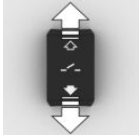

- ▶ Slide the switch back beyond the resistance point twice in quick succession.

The glass sunroof and the sun protection open together.

Pressing the switch again stops the movement.

- ▶ Slide the switch forwards beyond the resistance point twice in quick succession.

The glass sunroof and the sun protection close together.

Pressing the switch again stops the movement.

Comfort position

In some models, wind noise levels inside the vehicle are lowest when the glass sunroof is not fully open. On these models, the automatic function initially only opens the glass sunroof as far as this comfort position.

Pressing the switch again in the interior opens the electric glass sunroof fully.

Closing the glass sunroof automatically

Principle

An open electric glass sunroof is automatically moved to the raised position when it starts to rain or six hours after the vehicle was locked.

Operating requirements

- ▶ Rain must be able to reach the sensor field in the area of the interior mirror. The sensor

field may be obscured by a car port or bridge, for example.

- ▶ Vehicle must be in rest state.
- ▶ The function must be activated in the settings.

For settings, see page 100.

Malfuctions

The open glass sunroof is not moved to the raised position under the following circumstances:

- ▶ The glass sunroof is blocked.
- ▶ The anti-trap mechanism cannot be guaranteed.
- ▶ There is a system error, for example due to a temporary open circuit. In this case, initialising the glass sunroof can help.

An error message is shown on the control display. No further closure is attempted.

If rain detection is not possible due to the system, the open glass sunroof is immediately moved to the raised position. An error message is shown on the control display.

Anti-trap mechanism

Principle

The anti-trap mechanism prevents objects or parts of the body from becoming trapped between the roof frame and glass sunroof while the glass sunroof is being closed.

General

If resistance or an obstruction is detected while the glass sunroof is being closed, the closing operation is interrupted once the roof reaches the half-open position or when closing from the raised position.

Closing with no anti-trap mechanism from an open position

If an external hazard or ice prevents you from closing the windows normally, proceed as follows:

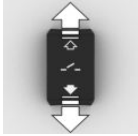

1. Close all doors.
2. Slide the switch forwards beyond the resistance point and hold it in this position.

The glass sunroof is closed with restricted anti-trap mechanism. If the closing force exceeds a certain level, the closing operation is interrupted.

3. Slide the switch forwards once again beyond the resistance point and hold until the glass sunroof closes with no anti-trap mechanism. Ensure that the closing range is clear.

Closing with no anti-trap mechanism from a raised position

If an external hazard or ice prevents you from closing the windows normally, proceed as follows:

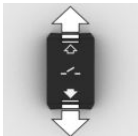

1. Close all doors.
2. Slide the switch forwards beyond the resistance point and hold it in this position.

Initialising after an open circuit

General

If an open circuit occurs while the glass sunroof is opening or closing, it may only have restricted functionality afterwards. In this case, initialising the system can help.

The system can be initialised if the following conditions are met:

- ▷ The vehicle is parked on level ground.
- ▷ The vehicle does not move until initialisation is complete.
- ▷ Drive-ready state is activated.
- ▷ The outside temperature is above 5 °C/41 °F.

During initialisation, the glass sunroof closes with no anti-trap mechanism.

Ensure that the closing range is clear.

Initialising the system



Press the switch up and hold until initialisation is complete:

Initialisation begins within 15 seconds.

- ▷ If the glass sunroof is closed, it opens, then closes again.
- ▷ If the glass sunroof is open, it first closes, then opens and closes again.

Initialisation is complete once the glass sunroof and sun protection have opened then closed again.

Seats, mirrors and steering wheel

Vehicle equipment

This chapter describes equipment, systems and functions which are offered or will be offered on a model-specific basis, even if they are not included in the vehicle in question.

For further information:

Vehicle equipment, see page 7.

Safe seating position

A seat position that suitably meets the needs of the occupants is essential for relaxed driving with minimum fatigue.

In an accident, the correct seat position plays an important role. Pay attention to the notes in the following chapters.

For further information:

- ▶ Seats, see page 110.
- ▶ Seat belts, see page 113.
- ▶ Head restraints, see page 116.
- ▶ Airbags, see page 186.

Seats

Safety notes

⚠ WARNING

Adjusting the seat during a journey could cause the seat to move unexpectedly. You could lose control of the vehicle. There is a risk of accident. Only adjust the seat on the driver's side when at a standstill.

⚠ WARNING

If the backrest is angled too far back, the protective function of the seat belt will no longer be guaranteed. There is a risk of sliding under the seat belt in the event of an accident. There is a risk of injury or even death. Adjust the seat before starting the journey. Adjust the backrest to the most upright position possible, and do not change it during the journey.

⚠ WARNING

There is a risk of entrapment when the seats are moved. There is a risk of injury or material damage. Before making any adjustment, make sure that the area of movement of the seat is clear.

Manually adjustable seats

Overview



The levers for the seat settings are located at the front seats.

Adjusting the forward/back position

⚠ WARNING

If the seat is not locked, it could move unexpectedly during a journey. You could lose control of the vehicle. There is a risk of accident. After making an adjustment, move the seat forwards and backwards slightly to ensure that it is properly engaged.



Pull the lever and slide the seat in the desired direction.

Adjusting the seat angle

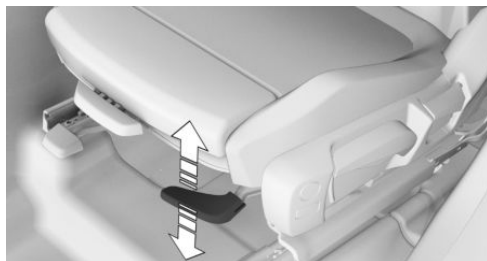

Pull the lever up or press the lever down repeatedly until the seat reaches the desired angle.

Adjusting the height

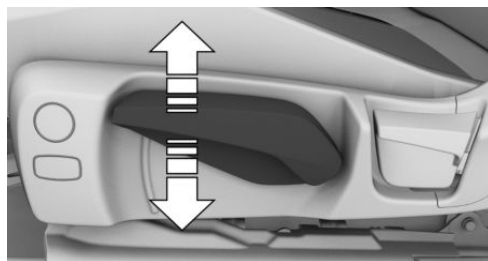

Pull the lever up or press the lever down repeatedly until the seat reaches the desired height.

Adjusting the backrest angle

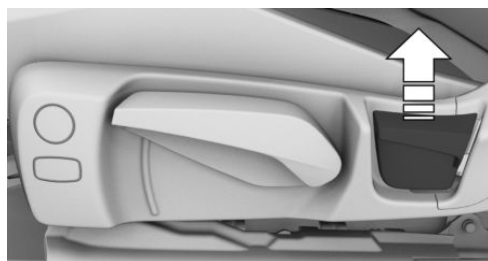

Pull the lever and add or remove pressure on the backrest as required.

Electrically adjustable seats

General

The seat setting for the driver's seat is stored in the active BMW ID or in the active driver profile. If the BMW ID or the driver profile is reactivated at a later time, the stored position is called up automatically.

The current seat position can be saved using the memory function.

Overview



The switches for the seat settings are located at the front seats.

Adjusting the seat angle

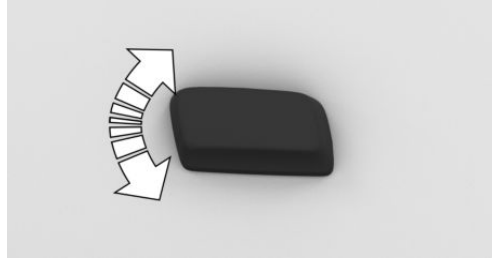

Tilt the switch up or down.

Adjusting the forward/back position

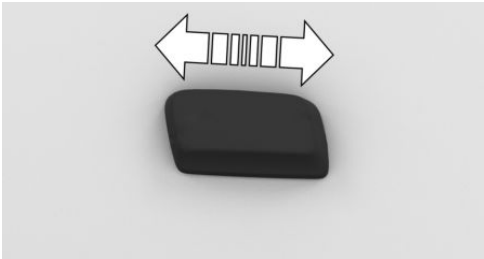

Press the switch forwards or backwards.

Adjusting the backrest angle

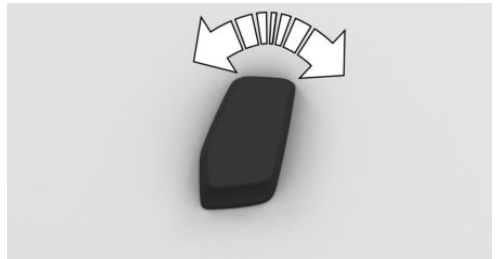

Tilt the switch forwards or backwards.

Adjusting the height

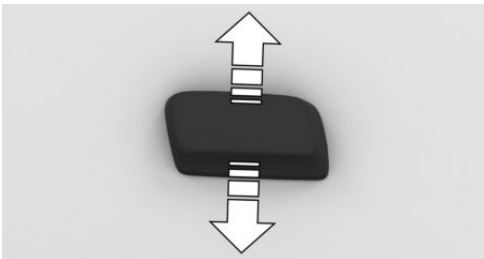

Press the switch up or down.

Thigh support

Sport seat

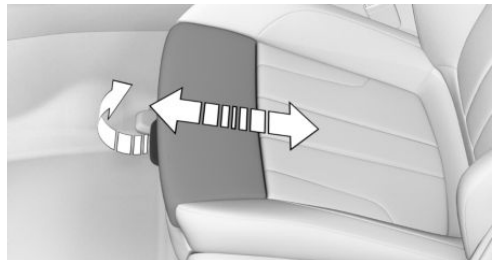

Pull the lever on the front of the seat and adjust the thigh support forwards or backwards.

Lumbar support

Principle

The curvature of the backrest can be changed to provide support for the lumbar region, or lordosis. The upper edge of the pelvis and the spinal column are supported to encourage an upright sitting posture.

Adjusting the lumbar support



- ▶ Press the button at the front/rear:
The curvature is increased/decreased.

- ▶ Press the button at the top/bottom:
The curvature is shifted upwards/downwards.

Backrest width

Principle

The backrest width can be adjusted to improve lateral support when cornering.

General

The backrest width is changed by adjusting the side sections of the backrest.

Adjusting the backrest width



- ▶ Press the button at the front:
Backrest width is reduced.
- ▶ Press the button at the rear:
Backrest width is increased.

Seat belts

General

For the safety of the vehicle occupants, the vehicle is equipped with five seat belts. However, they can only provide protective effect when worn correctly.

Before each journey, always make sure that all occupants have fastened their seat belts. The airbags supplement the seat belts as an additional safety device. The airbags are not a substitute for the seat belts.

All belt fastening points are designed to achieve the best possible protective effect of the seat belts with proper use of the seat belts and correct seat setting.

The two outer seat belt buckles on the rear seats are intended for those sitting on the left and right.

The inner seat belt buckle on the rear seats is intended for the person sitting in the middle.

For further information:

Notes on sitting safely, see page 110.

Safety notes

WARNING

If a seat belt is used by more than one person at the same time, the protective function of the seat belt is no longer guaranteed. There is a risk of injury or even death. Only one person should use each seat belt at any one time. Do not allow infants and children to travel on the lap of another occupant. Instead, secure the infant or child in a child restraint system intended for this purpose.

WARNING

The protective function of the seat belts may be limited or may even fail completely if the seat belts are worn incorrectly. If a seat belt is not worn correctly, additional injuries can be caused, for example in the event of an accident, braking or evasive action. There is a risk of injury or even death. Make sure that all vehicle occupants have fastened their seat belts correctly.

⚠ WARNING

Seat belts are designed to bear upon the bony structure of the body and should be worn low across the front of the pelvis, or the pelvis, chest and shoulders, as applicable. Wearing the lap section of the belt across the abdominal area must be avoided.

Seat belts should be adjusted as firmly as possible, consistent with comfort, to provide the protection for which they have been designed. A slack seat belt will greatly reduce the protection afforded to the wearer.

Care should be taken to avoid contamination of the webbing by polishes, oils and chemicals and particularly battery acid. Cleaning may safely be carried out using a mild soap and water solution. The seat belt should be replaced if the seat belt strap becomes frayed, contaminated or damaged. Seat belts should not be worn with straps twisted. Each seat belt assembly must only be used by one occupant; it is forbidden to put a belt around a child being carried on the occupant's lap.

It is essential to replace the entire assembly after it has been worn in a severe impact even if damage to the assembly is not obvious.

⚠ WARNING

No modifications or additions should be made by the user that will either prevent the seat belt adjusting devices from operating to remove slack, or prevent the seat belt assembly from being adjusted to remove slack.

⚠ WARNING

If the rear seat backrest is not locked, the protective effect of the middle seat belt is not ensured. There is a risk of injury or even death. Lock the wider rear seat backrest when using the middle seat belt.

⚠ WARNING

The protective effect of the seat belts may be restricted or may even fail completely in the following situations:

- ▷ If the seat belts or seat belt buckles are damaged, dirty or have been modified in another way.
- ▷ The seat belt tensioners or belt retractors have been modified.

Seat belts can be damaged in an accident without the damage necessarily being apparent. There is a danger of injury or danger to life. Do not modify seat belts, seat belt buckles, seat belt tensioners, belt retractors and belt anchor points and ensure that they are kept clean. After an accident, have the seat belts inspected at a Service Partner of the manufacturer or another qualified Service Partner or a specialist workshop.

Correct seat belt use

- ▷ Place the seat belt tightly over the pelvis and shoulder, close to the body and without twisting.
- ▷ Make sure that the seat belt is positioned low at the hips in the area of the pelvis. The seat belt must not press on the abdomen.
- ▷ The seat belt must not be allowed to rub against sharp edges, be routed over solid or breakable objects or be trapped.
- ▷ Avoid wearing bulky clothing.
- ▷ Keep the seat belt taut by occasionally pulling upwards on the upper body area.
- ▷ Centre seat belt in the rear: after buckling the seat belt, pull the seat belt buckle to the resistance out of the mount.

Setting for automatic retracting seat belts

- ▶ Draw the seat belt tongue attached to the seat belt across the body and press it into the seat belt buckle until a 'click' is heard.
- ▶ Adjustment of the belt length is very important. To adjust the lap belt and check whether the seat belt buckle has locked correctly, pull upwards on the shoulder strap until the lap belt fits tightly.
- ▶ The length of the diagonal shoulder strap adjusts itself automatically to allow freedom of movement.
- ▶ To release the seat belt, press the button on the seat belt buckle.

Fastening the seat belt

1. When fastening the seat belt, guide it slowly over the shoulder and pelvis.
2. Insert the seat belt tongue in the seat belt buckle. The seat belt buckle must be heard to engage.

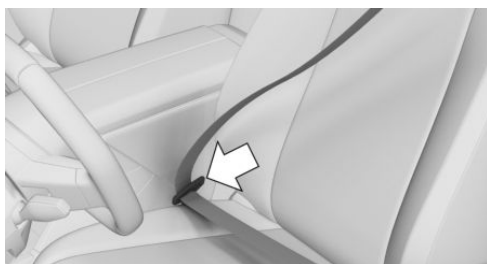

If fastened, the driver's and front passenger's seat belt strap is automatically tensioned once when driving off.

Unfastening the seat belt

1. Hold the seat belt firmly.
2. Press the red button on the seat belt buckle.
3. Guide the seat belt back up to the automatic reel.

Acoustic seat belt warning

General

Check whether the seat belts are fastened correctly.

The seat belt reminder becomes active in the following situations:





- ▶ When the seat belt on the driver's side or on the passenger's side is not fastened.
- ▶ When the seat belt is unfastened while driving.
- ▶ When objects are present on the front passenger seat.

Display in the instrument cluster

The indicator light in the instrument cluster illuminates after turning on the drive-ready state and the seat belt reminder is active.

A Check Control message is shown where applicable. Check whether the seat belt has been fastened correctly.

The displays may vary depending on the equipment and national-market version.

Icon	Meaning
	Seat belt is not buckled.
	Seat belt is only buckled on the corresponding seat.
	Seat belt on the corresponding seat is not buckled.
	This seat is not affected by the seat belt reminder.

Safety function

In critical driving situations, for example full braking, the front seat belts are tensioned automatically.

If the driving situation passes without an accident, the belt tension is slackened again.

If the belt tension does not loosen automatically, stop the vehicle and unfasten the seat belt by pressing the red button in the seat belt buckle. Fasten the seat belt again before continuing driving.

Front head restraints

Safety notes

WARNING

If the head restraints are removed or incorrectly adjusted, they cannot provide protection as intended and head and neck injuries may result. There is a danger of injury.

- ▷ Before a journey, re-install any removed head restraints on all occupied seats.
- ▷ Adjust the head restraint so that its centre supports the back of the head at eye level where possible.
- ▷ Adjust the distance so that the head restraint is as close as possible to the back of the head. If necessary, adjust the distance by adjusting the backrest angle.

WARNING

Parts of the body can become trapped when the head restraints are moved. There is a danger of injury. When moving the head restraint, make sure that the area of movement is kept clear.

WARNING

Objects on the head restraint impair the protective function of the head restraint in the head and neck area. There is a danger of injury.

- ▷ Do not fit any covers on the seats or head restraints.
- ▷ Do not hang objects such as coat hangers directly on the head restraint.
- ▷ Only use accessories that have been classified as safe for attaching to the head restraint.
- ▷ Do not use any accessories, for example cushions, during the journey.

Adjusting the height

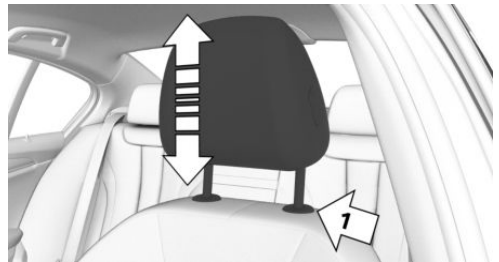

- ▷ Down: press the button, arrow 1, and slide the head restraint downwards.
- ▷ Up: push the head restraint upwards.

After adjusting the height, make sure that the head restraint engages correctly.

Adjusting the height: M sports seat

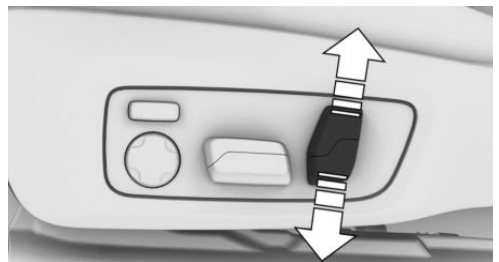

Press the switch up or down.

Adjusting the distance



- ▷ Back: press the button and push back the head restraint.
- ▷ Forward: pull the head restraint forwards.

After adjusting the distance, make sure that the head restraint engages correctly.

Adjusting the distance: M sports seat

The distance from the back of the head is adjusted by the seat backrest angle.

Adjust the distance so that the head restraint is as close as possible to the back of the head.

Removing the head restraints

Only remove the head restraint if no-one is intending to sit in the seat in question.

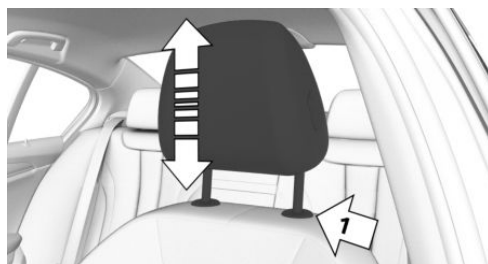

1. Push the head restraint up until resistance is felt.
2. Press the button, arrow 1, and pull the head restraint fully out.

Installing head restraints

Proceed in the reverse order to install the head restraint.

Rear head restraints

Safety notes

⚠ WARNING

If the head restraints are removed or incorrectly adjusted, they cannot provide protection as intended and head and neck injuries may result. There is a danger of injury.

- ▷ Before a journey, re-install any removed head restraints on all occupied seats.
- ▷ Adjust the head restraint so that its centre supports the back of the head at eye level where possible.
- ▷ Adjust the distance so that the head restraint is as close as possible to the back of the head. If necessary, adjust the distance by adjusting the backrest angle.

⚠ WARNING

Parts of the body can become trapped when the head restraints are moved. There is a danger of injury. When moving the head restraint, make sure that the area of movement is kept clear.

⚠ WARNING

Objects on the head restraint impair the protective function of the head restraint in the head and neck area. There is a danger of injury.

- ▷ Do not fit any covers on the seats or head restraints.
- ▷ Do not hang objects such as coat hangers directly on the head restraint.
- ▷ Only use accessories that have been classified as safe for attaching to the head restraint.
- ▷ Do not use any accessories, for example cushions, during the journey.

Folding down the head restraints

General

Head restraints can be folded back to improve rear visibility. Only fold back the head restraint if no one is sitting on the seat in question.

Folding down the head restraints

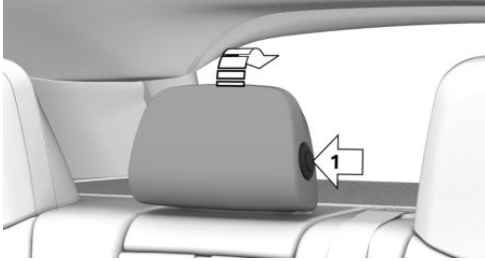

- ▶ Backwards: press the button, arrow 1, and fold back the head restraint.
- ▶ Forwards: fold the head restraint forwards as far as it will go. Ensure that the head restraint engages correctly.

Removing the outer head restraint

Only remove the head restraint if no-one is intending to sit in the seat in question.

1. Fold down the respective rear seat backrest.
To enlarge the luggage compartment, see page 294.
2. Insert the integrated key.

Integrated key, see page 84.

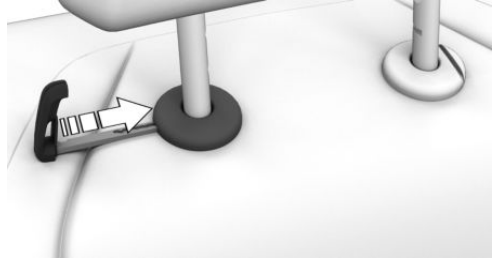

3. Press and hold the integrated key and the button simultaneously, arrows 1, and pull the head restraint fully out.

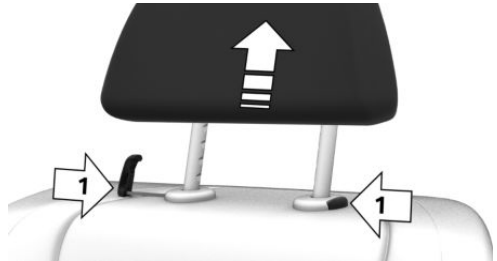

Removing the middle head restraint

Only remove the head restraint if no one is sitting on the middle seat.

1. Push the head restraint up until resistance is felt.
2. Press the buttons, arrows 1, and pull the head restraint fully out.

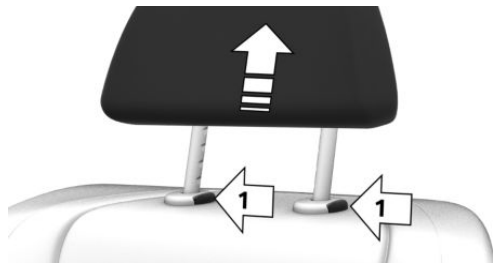

Installing head restraints

To install, insert the head restraint into the mount and push down until resistance is felt.

After installation, make sure that the head restraint engages correctly.

Exterior mirrors

General

The exterior mirror adjustment is stored in the active BMW ID or in the active driver profile. If the BMW ID or the driver profile is reactivated at a later time, the stored position is called up automatically.

The current exterior mirror adjustment can be stored using the memory function.



Safety note

WARNING

Objects reflected in the mirror are closer than they appear. The distance from road users behind the vehicle could be incorrectly estimated, for example when changing lane. There is a risk of accident. Look over your shoulder to estimate the distance from following traffic.

Overview



Icon	Meaning
	Fold the exterior mirror in and out.
	Adjust the exterior mirrors.
	Select mirror, automatic parking function.

Adjusting the exterior mirrors

-  Press the button.
- The selected exterior mirror moves along with the button movement.

Selecting the exterior mirror

-  To switch to the other mirror:
Push the switch.

Malfunction

In case of an electrical failure, adjust the exterior mirror by pressing on the edges of the mirror glass.

Folding in/folding out the exterior mirror

NOTE

Because of its width, the vehicle could sustain damage in car washes. There is a risk of material damage. Before washing, fold the mirrors in manually or with the button.

-  Press the button.

The mirrors can be folded in at vehicle speeds up to approx. 20 km/h/15 mph.

Folding the exterior mirrors in and out is helpful in the following situations:

- ▷ In car washes.
- ▷ In narrow streets.

Mirrors which are folded in automatically fold out when the vehicle reaches a speed of approximately 40 km/h/25 mph.

Automatic heating

When required, both exterior mirrors are automatically heated when drive-ready state is switched on.

Automatic dimming

The exterior mirror on the driver's side is dimmed automatically. Photocells in the interior mirror are used to control this function.

Automatic parking function

Principle

When reverse gear is engaged, the mirror glass on the passenger's side is tilted downwards. When parking, for example, this gives the driver a better view of the kerb or other objects near the ground.

Activating the automatic parking function

1. Push the switch to the driver's side exterior mirror position.



2. Engage selector lever position R.

The automatic parking function is deactivated when the trailer socket is occupied.

Deactivating the automatic parking function

Push the switch to the front passenger's side exterior mirror position.

Interior mirror, manual dim

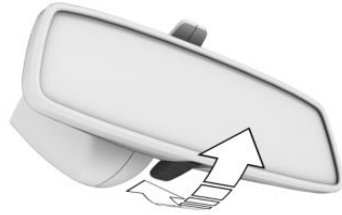

Reduce dazzling effect from the interior mirror by tilting the lever forward.

Rear-view mirror with automatic anti-dazzle function

General

The interior mirror is dimmed automatically. The function is controlled by photocells:

- ▷ In the mirror glass.
- ▷ On the back of the mirror.

Overview



Operating requirements

- ▷ Keep the photocells clean.
- ▷ Do not obstruct the zone between the interior mirror and the windscreen.

Steering wheel

Safety note

⚠ WARNING

Adjusting the steering wheel while driving may cause the steering wheel to move unexpectedly. You could lose control of the vehicle. There is a risk of accident. Only adjust the steering wheel when the vehicle is at a standstill.

Manual steering wheel adjustment

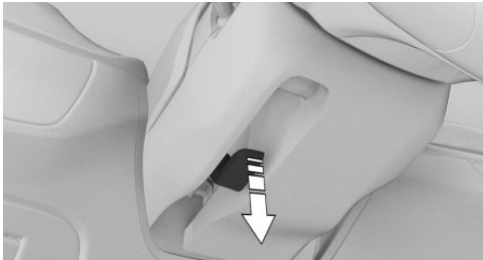

1. Fold the lever down fully.
2. Grip the steering wheel with both hands and adjust it in the longitudinal direction and height of the seat position.
3. Fold the lever back up.

Steering wheel heating

Overview



Button for steering wheel heating

Turning the steering wheel heating on/off

ⓘ Press the button.

A Check Control message is shown.

If a journey is resumed within about 15 minutes after a temporary stop, steering wheel heating switches on automatically provided that the function had been active at the end of the previous journey.

Memory function

Principle

The memory function enables the following settings to be stored and retrieved when required:

- ▷ Seat position.
- ▷ Exterior mirror adjustment.
- ▷ Depending on the equipment: height of the Head-up display.

General

For each driver profile, two memory slots can be assigned with different settings.

The following settings are not saved:

- ▷ Backrest width.
- ▷ Lumbar support.

Safety notes

⚠ WARNING

Using the memory function while driving may cause the seat or steering wheel to move unexpectedly. You could lose control of the vehicle. There is a risk of accident. Only call up the memory function when the vehicle is at standstill.

⚠ WARNING

There is a risk of entrapment when the seats are moved. There is a risk of injury or material damage. Before making any adjustment, make sure that the area of movement of the seat is clear.

Overview

The memory buttons are on the front doors.

Storing settings

1. Set the desired position.

2.  Press the button. The LED is illuminated.
3. Press the desired button 1 or 2 while the LED is illuminated. A signal sounds.

Go to Settings

Press the desired button 1 or 2.

The saved position is retrieved.

The operation is halted when you press a seat setting switch or press one of the memory buttons again.

The adjustment of the seat position on the driver's side is interrupted after a short time while driving.

Seat heating**General**

If a journey is resumed within about 15 minutes after a temporary stop, the functions are automatically switched on at the last temperature setting.

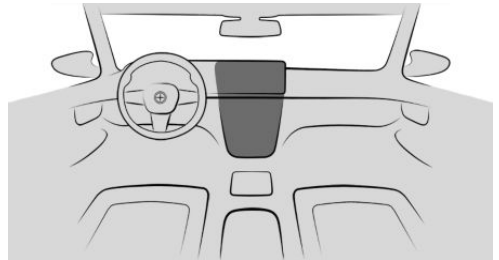
Automatic air conditioning**Overview****Turning the seat heating on/off**

1. "CLIMATE MENU" tap in the centre of the air conditioning bar.
2.  Seat heating.
3. Select the desired setting.

If ECO PRO is activated, the heater output is reduced.

For further information:

ECO PRO, see page 310.

Automatic rear air-conditioning system

Overview

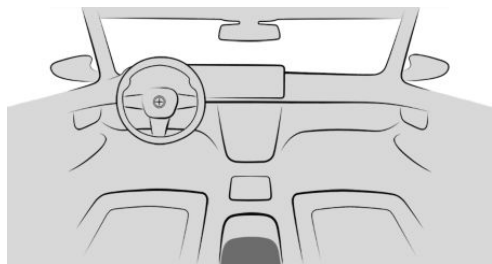

Turning on the seat heating



Press the button once for each temperature stage.

The highest temperature if the three LEDs are illuminated.

Turning off the seat heating



Press and hold the button until the LEDs are extinguished.

Active seat ventilation

Principle

Fans integrated into the seat cushion and backrest ensure a pleasant seating climate.

Turning active seat ventilation on/off

1. "CLIMATE MENU" tap in the centre of the air conditioning bar.
2.  Seat ventilation.
3. Select the desired setting.

Carrying children safely

Vehicle equipment

This chapter describes equipment, systems and functions which are offered or will be offered on a model-specific basis, even if they are not included in the vehicle in question.

For further information:

Vehicle equipment, see page 7.

Important considerations

Safety notes

WARNING

Unsupervised children or pets in the vehicle can set the vehicle in motion and endanger themselves or other road users, for example by the following actions:

- ▷ Pressing the Start/Stop button.
- ▷ Releasing the parking brake.
- ▷ Opening and closing doors or windows.
- ▷ Engaging selector lever position N.
- ▷ Operating vehicle equipment.

There is a risk of accident or injury. Do not leave children or pets unsupervised in the vehicle. When leaving the vehicle, take the vehicle key with you and lock the vehicle.

WARNING

Hot vehicles can have fatal consequences, in particular for children or pets. There is a risk of injury or even death. Do not leave anyone unsupervised in the vehicle, especially children or pets.

WARNING

Child restraint systems and their parts can get very hot when exposed to direct sunlight. Contact with hot parts can cause burns. There is a danger of injury. Do not expose the child restraint system to direct sunlight; cover the child restraint system if necessary. If necessary, allow the child restraint system to cool down before transporting a child. Do not leave children unsupervised in the vehicle.

Children on the rear seat

General

Accident research has shown that the safest place for children is on the rear seat.

Wherever possible, children younger than 12 years old or shorter than 150 cm, 5 ft should be transported only on the rear seats in child restraint systems appropriate for their age, weight and stature. Children aged 12 years and older must be secured with a seat belt once a suitable child restraint system is no longer an option due to their age, weight or stature.

Safety note

WARNING

Children shorter than 150 cm, 5 ft cannot wear the seat belt correctly without using additional child restraint systems. The protective effect of the seat belts may be restricted or may even fail completely if the seat belts are worn incorrectly. If a seat belt is not worn correctly, additional injuries can be caused, for example in the event of an accident, braking or avoidance manoeuvre. There is a danger of injury or danger

to life. Children shorter than 150 cm, 5 ft must be secured in suitable child restraint systems.

Not for Australia: Children on the front passenger seat

General

When using a child restraint system on the front passenger seat, make sure that the front and side airbags on the front passenger's side are deactivated. Airbags on the front passenger side can only be deactivated with the key switch for front passenger airbags.

If the front passenger airbags cannot be deactivated, do not carry children on the front passenger seat, even in suitable child restraint systems.

For further information:

Key switch for front passenger airbags, see page 188.

Safety note

WARNING

Active front passenger airbags can injure a child in a child restraint system when they deploy. There is a danger of injury. Make sure that the front passenger airbags are deactivated and the PASSENGER AIRBAG OFF indicator lamp is illuminated.

Fitting child restraint systems

General

Please comply with the operating and safety instructions provided by the child restraint system manufacturer when selecting, attaching and using child restraint systems.

Safety notes

WARNING

If child restraint systems and their attachment systems have been damaged or subjected to stresses in an accident, their protective function may be limited or may fail completely. A child might not be adequately restrained, for example in the event of an accident, braking or evasive action. There is a risk of injury or even death.

Do not continue to use child restraints which are damaged or have been subjected to stresses in an accident.

If attachment systems have been damaged or subjected to stresses in an accident, have them checked and replaced by a Service Partner of the manufacturer, another qualified Service Partner or a specialist workshop.

WARNING

If the seat is not set properly or the child seat has been installed incorrectly, the child restraint system may have restricted or no stability at all. There is a danger of injury or danger to life. Make sure that the child restraint system rests firmly against the seat backrest. Wherever possible, adapt the backrest angle of all relevant seat backrests and adjust the seats correctly. Make sure that the seats and their backrests are correctly engaged or locked. If necessary, adjust the height of the head restraints, or remove them.

For Australia: installation of child restraint systems

Please note the following warning because your vehicle has been equipped with a front airbag for the front passenger seat that cannot be deactivated:



It is recommended not to use any kind of child restraint system on the front passenger seat.

Extreme hazard

Do not use a rearward-facing child restraint on a seat protected by an airbag in front of it.

Not for Australia: On the front passenger seat

Deactivating airbags

WARNING

Active front passenger airbags can injure a child in a child restraint system when they deploy. There is a danger of injury. Make sure that the front passenger airbags are deactivated and the PASSENGER AIRBAG OFF indicator lamp is illuminated.

Before fitting a child restraint system on the front passenger seat, make sure that the front and side airbags on the front passenger's side are disabled. If the airbag cannot be deactivated, do not fit child restraint systems.

For further information:

Key switch for front passenger airbags, see page 188.

Rearward-facing child restraint systems

DANGER

If triggered, active front passenger airbags can fatally injure a child in a child restraint system which is mounted facing backwards. There is a danger of injury or danger to life. Make sure that the front passenger airbags are deactivated and the PASSENGER AIRBAG OFF indicator light is illuminated.



Follow the note on the sun visor on the passenger's side.

Never use a rearward-facing child restraint on a seat protected by an active front airbag, as death or serious injury to the child can occur.

Seat position and height

After installing a universal child restraint system, move the front passenger seat as far back as it will go and adjust it to the highest position. This seat position and height provides the best possible belt routing and protection in the event of an accident.

If the upper attachment point of the seat belt is in front of the child seat's seat belt guide, carefully move the front passenger seat forwards until the best possible seat belt guide is achieved.

Backrest width

With adjustable backrest width: before fitting a child restraint system on the front passenger seat, fully open the backrest width. Do not change the backrest width from this point on and do not retrieve a seat position from the memory.

ISOFIX or i-Size child safety seat fasteners

General

Please comply with the operating and safety instructions provided by the, child restraint system manufacturer when selecting, attaching and using ISOFIX or i-Size child restraint systems.



i-Size child restraint systems

General

i-Size is a legal regulation for child restraint systems which is used for the approval of child restraint systems.

The system represents a further development of the ISOFIX child safety seat fasteners.

ISOFIX child restraint systems can also be attached to anchors with i-Size markings.

Icon	Meaning
	If this icon is seen in the vehicle, the vehicle has also been approved in accordance with i-Size. The icon shows the mounts for the system's lower anchors. The lower anchors meet the European i-Size requirements.
	The corresponding icon shows the top tether eyelet.

Suitable ISOFIX or i-Size child restraint systems

Only certain ISOFIX or i-Size child restraint systems are permitted to be used on the designated seats. The associated size class and size category are denoted by a letter or ISO reference on a plate on the child seat.

For further information:

Suitable seats for child restraint systems, see page 129.

Fixtures for lower anchors

General

Observe the following when attaching child restraint systems with an integrated strap to the attachments for the lower anchors:

The total weight of the child and child restraint system must not exceed 33 kg, 73 lbs.

Safety notes

WARNING

If the child restraint system lower anchors are not engaged correctly, the protective effect of the child restraint system will be restricted. There is a danger of injury or danger to life. Make sure the lower anchor points have engaged correctly and the child restraint system rests firmly against the backrest.

WARNING

The mounts for the lower anchors and the attachment points for child restraint systems are intended for attaching child restraint systems only. The mounts or attachment points can be damaged if other objects are attached. There is a danger of injury or material damage. Only attach child restraint systems to the corresponding mounts for the lower anchors or the attachment points.

Position

Icon	Meaning
	The corresponding icon shows the fixtures for the lower ISOFIX anchors or i-Size mounting.

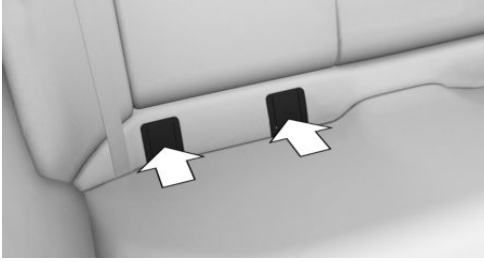

The fixtures for the lower ISOFIX anchors are located behind the marked covers.

Before fitting child restraint systems

Pull the seat belt away from the area of the child seat mountings.

Fitting child restraint systems

1. Install child restraint system, see the manufacturer's instructions.
2. Make sure that the child restraint system attachment correctly engages in the lower anchor on both sides.

Child restraint systems with upper restraint strap

Safety notes

WARNING

If the upper retaining strap is used incorrectly on the child restraint system, the protective effect will be reduced. There is a danger of injury. Make sure that the upper retaining strap is not twisted and is not routed to the upper mounting point over sharp edges.



WARNING

If the rear seat backrest is not locked, the protective effect of the child restraint system will be limited or lost. The rear seat backrest can fold forward in certain situations, for example when braking or in the event of an accident. There is a risk of injury or even death. Make sure that the rear seat backrests are locked.

WARNING

The mounts for the lower anchors and the attachment points for child restraint systems are intended for attaching child restraint systems only. The mounts or attachment points can be damaged if other objects are attached. There is a danger of injury or material damage. Only attach child restraint systems to the corresponding mounts for the lower anchors or the attachment points.

Attachment points for upper retaining strap

Icon	Meaning
 	The corresponding icon shows the top tether eyelet.



Depending on the equipment, there are two or three attachment points for the upper retaining strap of child restraint systems.

Attaching the upper retaining strap to the attachment point

1. Guide the upper retaining strap between or along both sides of the head restraint mounts to the attachment point.
2. Guide the retaining strap between the seat backrest and the luggage compartment cover.
3. Attach the hook of the retaining strap to the securing eye.
4. Tighten the retaining strap by pulling it firmly down.

Routing the retaining strap

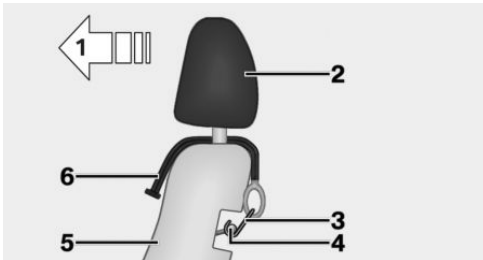

- 1 Direction of travel
- 2 Head restraint
- 3 Hook of the upper retaining strap
- 4 Attachment point
- 5 Seat backrest
- 6 Upper retaining strap

Suitable seats for child restraint systems

General

The legal provisions determining which child seat is permitted for which age and body size may vary from country to country. Please comply with the relevant national legal provisions.

Additional information is available from a Service Partner of the manufacturer or another qualified Service Partner or a specialist workshop.

For detailed information about using child restraint systems:

Seats for child restraint systems, see page [381](#).

Seats and child restraint systems

The following section provides information on which child restraint system is suitable for which seat in the vehicle.

Left-hand drive vehicles, seats:

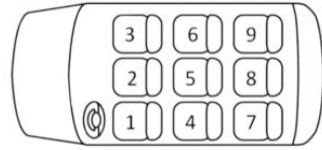









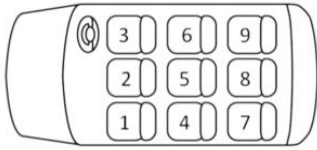

Seat	Airbag, front passenger	Mounting
1		
3 a)	ON	
	OFF	
4, 6 - b)		
5 - c, d)		

e)

- a) Adapt the forward/back position of the front passenger seat and, if necessary, move it to the highest position to achieve the best possible belt routing.
- b) When using child seats on the rear seats, if necessary adjust the forward/back position of the front seat and, if necessary, adjust or remove the head restraint of the rear seat.
- c) Only use the outer seats if the seat belt buckles are easily accessible.
- d) The seat is not suitable for child seats with a support stand.
- e) Depending on the equipment or national-market version.

Right-hand drive vehicle, seats:



Seat	Airbag, front passenger	Mounting			
1 a)	ON				
	OFF				
3					
4, 6 - b)					 e)
5 - c, d)					







a) Adapt the forward/back position of the front passenger seat and, if necessary, move it to the highest position to achieve the best possible belt routing.

b) When using child seats on the rear seats, if necessary adjust the forward/back position of the front seat and, if necessary, adjust or remove the head restraint of the rear seat.

c) Only use the outer seats if the seat belt buckles are easily accessible.

d) The seat is not suitable for child seats with a support stand.

e) Depending on the equipment or national-market version.

Icon	Meaning	Icon	Meaning
	Not suitable for child restraint systems.		Suitable for ISOFIX child restraint systems.
	Suitable for Universal-category child restraint systems approved for use in this weight group.		Suitable for ISOFIX and i-Size child restraint systems.
	Suitable for child restraint systems in the Semi-Universal category if the vehicle and the seat location are listed in the list of vehicle types from the manufacturer of the child restraint system.		Suitable for child restraint systems with an upper retaining strap.

Recommended child seats

Please comply with the operating and safety instructions provided by the child restraint system manufacturer when selecting, attaching and using child restraint systems.

The manufacturer of the vehicle recommends the following child restraint systems:

- ▶ Maxi-Cosi CabrioFix.
- ▶ Maxi-Cosi EasyFix Base.
- ▶ Römer TRIFIX 2.
- ▶ Römer KIDFIX series.

For Australia: Child restraint systems

General

In accordance with ADR 34/03, provisions have been made to allow installation of a child restraint system at each rear seat position.

The anchoring hooks which belong to the upper restraining strap of the child restraint system - AS 1754, can be applied immediately to the relevant mount.

Please refer strictly to the installation instructions supplied with the child restraint system.

Each seat position is fitted with a head restraint.

Safety notes

WARNING

Child restraint anchorages are designed to withstand only those loads imposed by correctly fitted child restraints. Under no circumstances are they to be used for adult seat belts, harnesses or for attaching other items or equipment to the vehicle. After using and removing child restraints, fold away the anchor brackets if necessary.



WARNING

If the rear seat backrest is not locked, the protective effect of the child restraint system will be limited or lost. The rear seat backrest can fold forward in certain situations, for example when braking or in the event of an accident. There is a risk of injury or even death. Make sure that the rear seat backrests are locked.

WARNING

If the upper retaining strap is used incorrectly on the child restraint system, the protective effect will be reduced. There is a danger of injury. Make sure that the upper retaining strap is not twisted and is not routed to the upper mounting point over sharp edges.

Attachment points

Icon	Meaning
 	The corresponding icon shows the top tether eyelet.

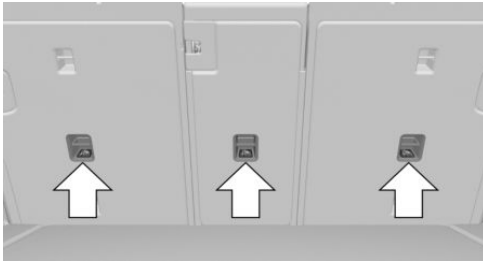

Depending on the equipment, there are two outer attachment points or three other attachment points for child restraint systems with tether straps.

Routing the retaining strap

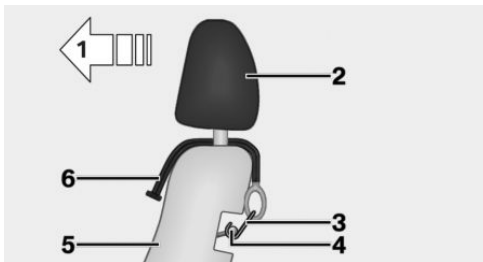

- 1 Direction of travel
- 2 Head restraint
- 3 Hook of the upper retaining strap
- 4 Attachment point
- 5 Seat backrest
- 6 Upper retaining strap

Attaching the upper retaining strap to the attachment point

1. Outer seats: guide the upper retaining strap between or along both sides of the head restraint mounts to the attachment point.

Middle seat: raise the head restraint if necessary by pressing the button on the brackets. Guide the upper retaining strap between or along both sides of the head restraint mounts to the attachment point.

2. Guide the retaining strap between the seat backrest and the luggage compartment cover.
3. Attach the hook of the retaining strap to the securing eye.
4. Tighten the retaining strap by pulling it firmly down.
5. Middle seat: push the head restraint down if necessary and engage it in place.

Securing doors and windows in the rear



General

In certain situations, for example when carrying children, it may be advisable to secure the rear doors and windows.

Doors





Unlock or lock the safety switches on the rear doors with the integrated key.

Icon	Function
	Child locks are unlocked.
	Child locks are locked.

The respective door can now only be opened from the outside.

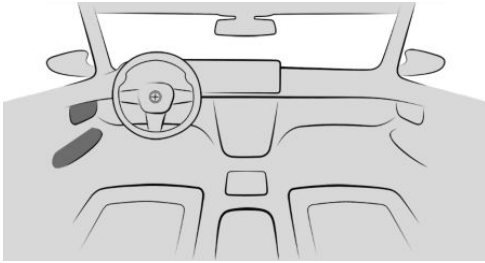
Rear safety switch



-  Press the button on the driver's door. Different functions are locked and cannot be operated in the rear, for example the window lifters.

Driving

Vehicle equipment

This chapter describes equipment, systems and functions which are offered or will be offered on a model-specific basis, even if they are not included in the vehicle in question.

For further information:

Vehicle equipment, see page 7.

BMW eDRIVE

Principle

BMW eDRIVE refers to the electric drive technology. The vehicle is equipped with a high-voltage system consisting of an electric motor on the rear axle and a high-voltage battery. With xDrive, a second electric motor is located on the front axle.

General

The eDRIVE system has the following special features:

- ▶ The vehicle is driven emission-free using its electric drivetrain.
- ▶ The special high-voltage battery supplies the electric motors as well as the comfort functions with power.
- ▶ The high-voltage battery is charged when parked using a charging cable, for example, or when driving by energy recuperation.
- ▶ Charging can be carried out particularly quickly at special charging stations. Charging at domestic electric sockets is also possible.
- ▶ While driving, energy recuperation ensures that as little energy as possible is lost from braking.
- ▶ When the vehicle decelerates, the electric motors act as alternators and convert the ki-

netic energy released into electric energy. The electrical energy partially recharges the high-voltage battery to increase the range.

- ▶ The rear electric motor powers the rear wheels.

With xDrive, the vehicle has an electrical all-wheel drive. The front wheels are powered by the second electric motor.

Overview

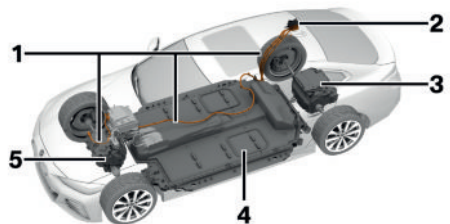

- 1 High-voltage cables, orange
- 2 High-voltage charging socket
- 3 Drive unit, rear
- 4 High-voltage battery
- 5 With xDrive: drive unit, front

Functions

Electric driving: eDRIVE

The vehicle is driven by electric power.

The accelerator pedal can be used not only for accelerating but also for decelerating.

During deceleration, the electric motors act as alternators and charge the high-voltage battery. When an anticipatory driving style is adopted, this function offers very efficient energy recuperation and the comfort and convenience of driving using only the accelerator.

Acoustic pedestrian protection

Depending on the national-market version, the acoustic protection for pedestrians generates a continuous driving noise.

- ▶ With a stationary vehicle and turned on drive-ready state as soon as the selector lever position P is exited.
- ▶ When driving up to 30 km/h/20 mph.

A loudspeaker system plays the noise outside the vehicle.

As a result, other road users, for example pedestrians or cyclists, can detect the vehicle better.

Energy recuperation: CHARGE

When driving, the high-voltage battery is charged by energy recuperation.

The electric motors act as alternators and convert the kinetic energy of the vehicle into electrical energy.

The high-voltage battery can be charged while driving in different situations:

- ▶ The accelerator pedal is only slightly depressed.
- ▶ The accelerator pedal not depressed.
- ▶ The pressure on the accelerator pedal is reduced.

Display

The displays provide information about the drive system's current status and illustrate how it is being used.

For further information:

Displays, see page 153.

Energy-saving driving and maximising range

General

Energy-saving driving is the basic prerequisite for as large a range as possible. eDRIVE provides various functions that assist with an energy-sav-

ing driving style. The eDRIVE functions assist in controlling the range and increase it, if necessary. The following descriptions provide an overview of the functions available and the individual measures that can be taken:

Before a journey

eDRIVE allows pre-conditioning of the vehicle before start of a journey. The pre-conditioning provides greater range than with complete air conditioning while the vehicle is in motion.

Depending on the equipment: pre-temperature setting while charging ensures that the maximum range is available at the start of the journey.

For further information:

Pre-conditioning, see page 280.

Journey planning and special functions of the navigation system

The navigation system offers special functions which take the electric range into account when planning a trip:

- ▶ Range map: displays the operating radius in the navigation map, see integrated Owner's Handbook.
- ▶ Charging station assistant under the Points of Interest in the navigation system helps in finding and, if necessary, scheduling a stop at a public charging station along the desired route, see integrated Owner's Handbook.

When driving

- ▶ "ECO PRO": activate drive mode to increase the range.
ECO PRO, see page 145.
- ▶ Information on the current driving condition. Displays in the Live Vehicle menu, driving condition, see page 173.
- ▶ Follow notes to increase the range.
Increasing the range, see page 309.
- ▶ Follow the notes for optimising driving style.

To use the eDRIVE system efficiently, see page 311.

- ▶ For efficient driving style, activate adaptive recuperation

For adaptive recuperation, recuperation, see page 313.

After driving

- ▶ Charge the vehicle and plan the next trip.
Charging the vehicle, see page 316.
- ▶ Follow preparations for long stationary periods.
Service life of the high-voltage battery, long stationary periods and putting the vehicle out of use, see page 325.

BMW app

The BMW app provides mobility-based services and applications.

Safety of the high-voltage system

Follow the information on the safety of the high-voltage system.

For further information:

Safety of the high-voltage system, see page 21.

Operating noises

Operating noises may arise due to the electrical system. These operating noises can occur in the following situations:

- ▶ When the high-voltage battery is being cooled during the charging process.
- ▶ When the high-voltage battery is being cooled when drive-ready state is switched on.
- ▶ When climate control is being used.

High-voltage battery, long stationary periods

Follow notes on laying up the vehicle and extended stationary phases.

For further information:

Service life of the high-voltage battery, long stationary periods, see page 325.

Start/Stop button

Principle

Drive-ready state is switched on and off by pressing the Start/Stop button.

Drive-ready state is switched on by pressing the Start/Stop button with the brake applied.

Pressing the Start/Stop button again switches drive-ready state off again and standby state is switched on.

Drive-ready state cannot be switched on when the charging cable is connected.

For further information:

- ▶ Drive-ready state, see page 52.
- ▶ Standby state, see page 52.
- ▶ Charging cable, see page 318.

Drive-ready state in detail

Safety note

WARNING

An unsecured vehicle can start moving and rolling away. There is a risk of accident. Before leaving the vehicle, secure it to prevent it from rolling away.

Observe the following to ensure that the vehicle is secured against rolling away:

- ▶ Apply the parking brake.
- ▶ Turn the front wheels towards the kerb on upward or downward gradients.
- ▶ Additionally secure the vehicle on upward or downward gradients, for example with a chock.

Switching on drive-ready state

1. Close the driver's door.
2. Press the brake.
3. Press the Start/Stop button.

An acoustic signal sounds. Drive-ready state is switched on.

Display in the instrument cluster



The READY indicator shows that the vehicle is ready to drive.

Starting to drive

Operating requirements

Driving is possible if the following conditions are met:

- ▶ The high-voltage battery is sufficiently charged.
- ▶ The driver's door is closed.
- ▶ Charging cable is disconnected.

Driving

1. Switch on drive-ready state.
2. Press the brake and engage selector lever position D, B or R.
3. Release the parking brake.
4. Drive away by applying the accelerator pedal.

Charge state with widely fluctuating temperatures

If there are significant temperature fluctuations and the charge level of the high-voltage battery is low, it might no longer be possible to start the vehicle for the next trip. Recharge the vehicle in good time if the charge state is low.

Selector lever positions

Display

The engaged selector lever position is shown in the instrument cluster and on the selector lever.

D drive position

Selector lever position for all normal driving.

When the brake pedal is released, the vehicle drives off slowly.

R reverse gear

Only engage selector lever position R when the vehicle is stationary.

N neutral

In selector lever position N, the vehicle can be pushed or can roll without drivetrain, for example in car washes.

P Park

Selector lever position for parking the vehicle. In selector lever position P, the drivetrain is blocked.

Only engage selector lever position P when the vehicle is stationary.

Selector lever position P is automatically engaged in situations such as the following:

- ▶ After switching off drive-ready state when selector lever position D, R or B is engaged.
- ▶ While drive-ready state is switched on and selector lever position D, R or B is selected, the driver's seat belt is unfastened, the driver's door is opened and neither the brake pedal nor the accelerator pedal is pressed.
- ▶ When standby state is switched off.

Before exiting the vehicle, make sure that selector lever position P is engaged and the parking brake is engaged. The vehicle could otherwise start to move.

For further information:

Parking brake, see page [145](#).

B drive position with highest energy recovery

Principle

Selector lever position B is the drive position with the highest energy recovery.

General

Selector lever position B offers the following characteristic:

- ▶ High level of energy recuperation when the accelerator pedal is released.
- ▶ Major deceleration when releasing the accelerator pedal, if necessary to a standstill of the vehicle.
- ▶ The vehicle does not drive off when the brake pedal is released.

Engaging selector lever positions

General

Keep the brake applied until you are ready to drive off, otherwise the vehicle will move when a drive position is selected.

Operating requirements

- ▶ The selector lever will only move from position P to another selector lever position if drive-ready state is switched on and the brake is pressed.
- ▶ It may not be possible to move out of selector lever position P until all technical conditions are met.
- ▶ Before shifting out of selector lever position P, remove the charging cable from the vehicle; otherwise, the gearshift request will not be executed.

Engaging selector lever position D, N, R

A selector lever lock prevents the following incorrect operation:

- ▶ Inadvertent shifting to selector lever position R.
- ▶ Inadvertent change from selector lever position P to another selector lever position.

1. Fasten the driver's seat belt.
2. Press and hold the button to cancel the selector lever lock.

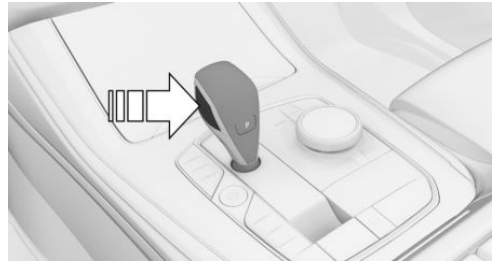

3. Briefly tap the selector lever in the desired direction, beyond a resistance point if required. The selector lever returns to the centre position when released.

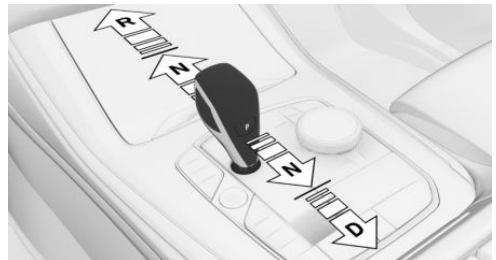

Engaging selector lever position P



Press button P.

Engaging selector lever position B

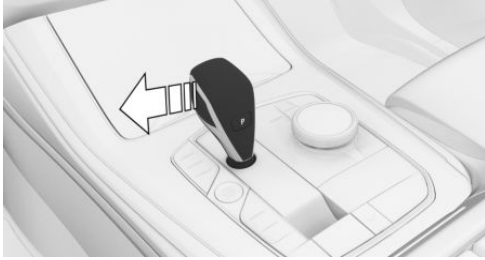

Press the selector lever out of selector lever position D to the left.

When stopping the vehicle

Selector lever position D or R

On uphill gradients, the system prevents the vehicle from rolling against the selected direction of travel and provides assistance when driving off.

Selector lever position B

The system prevents the vehicle from rolling when it has come to a standstill and the accelerator pedal is not pressed.

Automatic parking brake

The parking brake is automatically applied when the vehicle is stationary in the following conditions:

- ▷ Drive-ready state is switched off.
- ▷ The driver's door is opened.

Driving off

Engage a drive position and step on the accelerator pedal to drive off.

The parking brake is automatically released.

Rolling or pushing the vehicle

General

In some situations, the vehicle may need to roll a short distance without drivetrain, for example in a car wash, or when being pushed.

Engaging selector lever position N

NOTE

Selector lever position P is automatically engaged when standby state is switched off. There is a risk of material damage. Do not switch off standby state in car washes.

1. Switch on drive-ready state while pressing the brake.
2. If necessary, release the parking brake.
3. If necessary, switch off Automatic Hold.
4. Press the brake.
5. Operate the selector lever lock and engage selector lever position N.
6. Switch off drive-ready state.

Standby state then remains switched on and a Check Control message is shown.

The vehicle can now roll.

Irrespective of standby state, selector lever position P is engaged automatically after approximately 35 minutes.

If there is a fault, it may not be possible to change the selector lever position.

Unlock the parking lock electronically if necessary.

Unlocking the parking lock electronically

General

Unlock the parking lock electronically to manoeuvre the vehicle out of danger.

Before unlocking the parking lock, secure the vehicle to prevent it from rolling away, for example with a chock.

Engaging selector lever position N

1. Press the Start/Stop button three times; do not press the brake when doing so.
2. Press the brake.
3. Press the button on the selector lever, arrow 1, and press the selector lever to position N.

A corresponding Check Control message is shown.

Position N is displayed on the selector lever.



4. Manoeuvre the vehicle out of danger and then secure it against rolling away.

Switching off drive-ready state

When shutting down the vehicle, electrical system operating noises may be heard, for example if the high-voltage battery is being cooled.

After stopping:

1. Press the brake and engage selector lever position P.
2. Apply the parking brake.
3. Press the Start/Stop button.

The READY display is no longer illuminated and an acoustic signal is heard.

For longer stationary periods, follow the notes in the mobility chapter.

Service life of the high-voltage battery, long stationary periods and putting the vehicle out of use, see page 325.

Driving in detail: eDRIVE

Safety notes

! DANGER

The brake effect of the electric motor may be stronger than the effect in a vehicle with internal combustion engine. A sudden decrease in speed can lead to a hindrance to other road users. There is a risk of accident. Gently release the accelerator pedal. Adapt your driving style to the traffic conditions. Observe the traffic situation and intervene actively if the situation warrants it.

! WARNING

When driving using electric power, pedestrians and other road-users might not become aware of the vehicle as they normally would due to the lack of engine noise. There is a risk of accident. Adapt your driving style to the traffic conditions. Observe the traffic situation and intervene actively if the situation warrants it.

! WARNING

Without energy recuperation, the braking effect of the electric drivetrain is not available. The vehicle may roll further than usual. There is a risk of accident. Adapt your driving style to the traffic conditions. Observe the traffic situation and intervene actively if the situation warrants it.

Accelerator pedal positions, displays

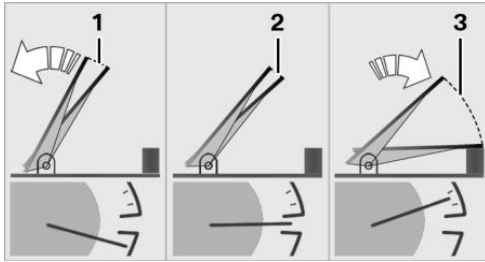

- 1 Deceleration and recuperation, CHARGE
- 2 Rolling
- 3 Acceleration or constant speed: ePOWER

Deceleration and energy recuperation

Deceleration

The intensity of the deceleration depends on the selector lever position, energy recuperation setting and the driving situation.

Depending on the intensity of the deceleration, the brake lights illuminate, without the brake pedal being applied.

Powerful deceleration is achieved in selector lever position B.

During deceleration, the energy is recuperated and the high-voltage battery charged.

Reduced deceleration

WARNING

Without energy recuperation, the braking effect of the electric drivetrain is not available. The vehicle may roll further than usual. There is a risk of accident. Adapt your driving style to the traffic conditions. Observe the traffic situation and intervene actively if the situation warrants it.

If there is a risk, for example, of locking wheels, energy recuperation – and hence deceleration – is reduced to prevent unstable driving conditions.

Energy recuperation: CHARGE

With the CHARGE energy recovery, the electric motors acts as alternators when decelerating and convert the kinetic energy of the vehicle to electrical energy.

Energy recuperation partially re-charges the high-voltage battery.

Energy can be recuperated if the following conditions are met:

- ▶ The vehicle is moving.
- ▶ Selector lever position B, D or R is engaged.
- ▶ The accelerator pedal not depressed or only slightly depressed.

Energy recuperation is shown in the instrument cluster.

For further information:

Power display, see page 163.

Energy cannot be recovered, for example in the following situations:

- ▶ Selector lever position N is engaged.
- ▶ While driving stability control systems are active or controlling the vehicle, even though this is not indicated by an indicator light.
- ▶ The high-voltage battery is completely charged.
- ▶ When the temperature of the high-voltage battery is very low or very high.

In winter, it is possible that energy recuperation is temporarily not available after starting.

Examples of driving situations

If a deceleration process is anticipated while driving, this can be used for energy recuperation.

The following examples of driving situations may be suitable for this:

- ▶ Deceleration on a downhill gradient.
- ▶ Deceleration before a red light.

Avoid late or heavy braking. Instead, decelerate the vehicle by energy recuperation.

Level of energy recuperation

High energy recuperation and powerful deceleration are achieved in selector lever position B.

For driving in selector lever position D, the strength of energy recovery can be adjusted via iDrive.

- ▶ Depending on the equipment, adaptive energy recovery: energy recovery and deceleration are automatically adapted to the respective driving situation.
Adaptive recuperation, recuperation, see page 313.
- ▶ High energy recuperation: the vehicle decelerates powerfully, more energy is fed back into the high-voltage battery.
- ▶ Medium energy recuperation.
- ▶ Low energy recuperation: the vehicle decelerates less powerfully, less energy is fed back into the high-voltage battery.

Setting the strength of energy recovery

1. "MENU"
2. "Vehicle apps"
3. "Driving settings"
4. "Drivetrain and chassis"
5. "Energy recovery in D"
6. Select the desired setting.

Heavily discharged high-voltage battery

If the high-voltage battery is heavily discharged during driving, the drive power and some comfort functions are reduced gradually in order to extend the range.

Overheated high-voltage battery

When the vehicle is stationary

In exceptional cases it is possible that the high-voltage battery overheats significantly when the vehicle is stationary, for example in extreme out-

side temperatures and direct sunlight. If the high-voltage battery overheats, drive-ready state cannot be switched on.

A Check Control message is shown.

A message is also shown when drive-ready state is available again.

While the vehicle is moving

If the high-voltage battery overheats during the journey, the drive power is reduced in steps to cool down the high-voltage battery. The ePOWER power display in the instrument cluster drops. If the temperature continues to rise, stop the vehicle until the high-voltage battery has cooled down. If the power display falls to 0, drive-ready state is switched off and the vehicle comes to a standstill.

i4 M50: Launch Control

Principle

When the ambient conditions are dry, Launch Control permits optimised acceleration on a road surface that offers plenty of grip.

General

Use of Launch Control causes premature component wear, as the function subjects the vehicle to very high stresses and loads.

Do not use Launch Control when running in.

When starting with Launch Control, do not turn the steering wheel.

For further information:

Running in, see page 298.

Driving off with Launch Control

1. Switch on drive-ready state.
2. Activate SPORT BOOST with Driving Experience Control.
3. Press the brake firmly with the left foot.

- Depress the accelerator pedal all the way down and hold it.
A destination flag is shown in the instrument cluster.

- Release the brake within 3 seconds of the destination flag illuminating.

The vehicle accelerates.

Launch Control remains active as long as the destination flag is displayed and the accelerator pedal remains depressed.

Driving Experience Control

Principle

Driving Experience Control influences the driving dynamics characteristics of the vehicle.

Various drive modes allow the vehicle to be adapted to suit the situation.

General

The following systems are influenced, for example:

- ▶ Drivetrain.
- ▶ Suspension.
- ▶ Steering.
- ▶ Display in the instrument cluster.
- ▶ Cruise Control.

Overview

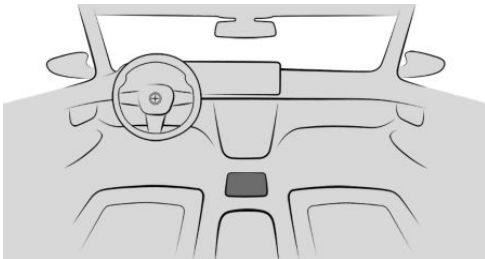

Displays in the instrument cluster



The selected drive mode is shown in the instrument cluster.

Drive modes

Button	Drive mode
SPORT	SPORT
	SPORT INDIVIDUAL
	SPORT BOOST
COMFORT	COMFORT
ECO PRO	ECO PRO
	ECO PRO INDIVIDUAL

Activating/deactivating the drive mode

Press the button of the desired drive mode repeatedly until the desired drive mode is displayed in the instrument cluster.

When the drive mode is changed, the current drive mode is deactivated.

Drive modes in detail

COMFORT

The COMFORT drive mode is a balanced setting between sporty and consumption-optimised driving.

Depending on the equipment: SPORT

The SPORT drive mode is a dynamic setting for greater agility with an optimised suspension.

Depending on the equipment: SPORT BOOST

If available, the electric motor provides additional output in the SPORT BOOST drive mode. Dynamic setting for maximum agility with an adapted drivetrain.

The additional output is accessed via the accelerator pedal while SPORT BOOST is active. A display in the instrument cluster indicates the availability of the BOOST output.

ECO PRO

The ECO PRO drive mode provides a consumption-optimised setting.

INDIVIDUAL configuration

General

The most recent custom configuration is activated when the drive mode is called up again.

Configuring and resetting

For example, ECO INDIVIDUAL drive mode:

1. "MENU"
2. "Vehicle apps"
3. "Driving settings"
4. "Drivetrain and chassis"
5. "ECO PRO INDIVIDUAL"
6. Select the desired setting.

To reset ECO PRO INDIVIDUAL to the default setting:

"Reset to ECO PRO STANDARD"

Activating the drive mode configuration

Press the button of the desired drive mode several times.

Parking brake

Principle

The parking brake is used to prevent the vehicle from rolling when it is parked.

Safety notes

WARNING

An unsecured vehicle can start moving and rolling away. There is a risk of accident. Before leaving the vehicle, secure it to prevent it from rolling away.

Observe the following to ensure that the vehicle is secured against rolling away:

- ▷ Apply the parking brake.
- ▷ Turn the front wheels towards the kerb on upward or downward gradients.
- ▷ Additionally secure the vehicle on upward or downward gradients, for example with a chock.

WARNING

Unsupervised children or pets in the vehicle can set the vehicle in motion and endanger themselves or other road users, for example by the following actions:

- ▷ Pressing the Start/Stop button.
- ▷ Releasing the parking brake.
- ▷ Opening and closing doors or windows.
- ▷ Engaging selector lever position N.
- ▷ Operating vehicle equipment.

There is a risk of accident or injury. Do not leave children or pets unsupervised in the vehicle. When leaving the vehicle, take the vehicle key with you and lock the vehicle.

Overview

Button in the vehicle

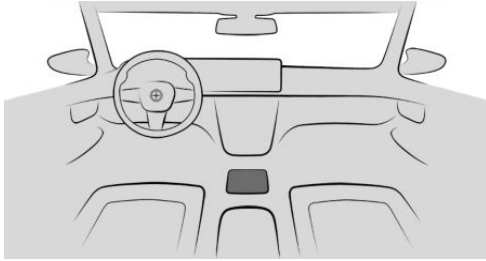

Applying the parking brake

When the vehicle is stationary

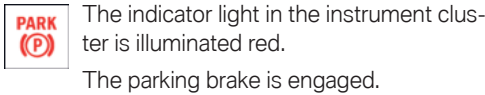
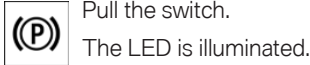

While the vehicle is moving

The parking brake can be used as an emergency braking function while driving:

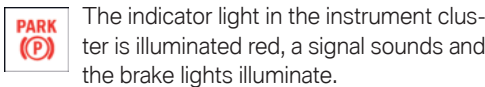
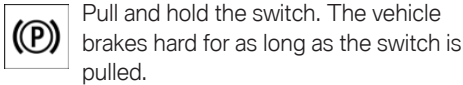

A Check Control message is shown.

Apply the parking brake when the vehicle is stationary.

With Emergency Stop Assistant

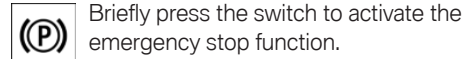

For further information:

Emergency Stop Assistant, see page 210.

Release the parking brake

Releasing the parking brake manually

1. Switch on drive-ready state.

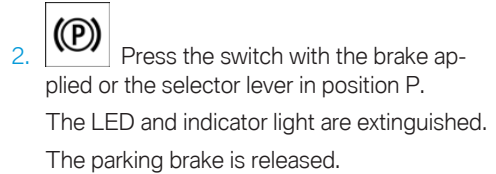

Releasing the parking brake automatically

The parking brake is automatically released on driving off.

The LED and indicator light are extinguished.

Malfunction

If the parking brake has failed or malfunctioned, secure the vehicle to prevent it from rolling away before leaving the vehicle.

A Check Control message is shown.

After getting out, secure the vehicle to prevent it from rolling away, for example with a chock.

After an open circuit

To restore the operability of the parking brake after a power failure, an initialisation may be required.

1. Switch on standby state.

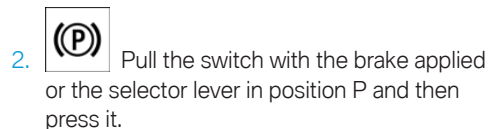

The procedure can take a few seconds. Any sounds that occur are normal.



The indicator light is extinguished once the parking brake is operational again.

Automatic Hold

Principle

Automatic Hold provides assistance by automatically applying and releasing the brake, for example in stop-and-go traffic.

The vehicle is held automatically when at a standstill.

On upward gradients, it prevents the vehicle from rolling back when driving off.

General

The parking brake is automatically applied in the following conditions:

- ▷ Drive-ready state is switched off.
- ▷ When the driver's door is opened while the vehicle is stationary.
- ▷ If the moving vehicle is brought to a standstill with the parking brake.

Safety notes

WARNING

An unsecured vehicle can start moving and rolling away. There is a risk of accident. Before leaving the vehicle, secure it to prevent it from rolling away.

Observe the following to ensure that the vehicle is secured against rolling away:

- ▷ Apply the parking brake.
- ▷ Turn the front wheels towards the kerb on upward or downward gradients.
- ▷ Additionally secure the vehicle on upward or downward gradients, for example with a chock.

WARNING

Unsupervised children or pets in the vehicle can set the vehicle in motion and endanger themselves or other road users, for example by the following actions:

- ▷ Pressing the Start/Stop button.
- ▷ Releasing the parking brake.
- ▷ Opening and closing doors or windows.
- ▷ Engaging selector lever position N.
- ▷ Operating vehicle equipment.

There is a risk of accident or injury. Do not leave children or pets unsupervised in the vehicle. When leaving the vehicle, take the vehicle key with you and lock the vehicle.

NOTE

Automatic Hold applies the parking brake when the vehicle is stationary and will prevent the vehicle from rolling in car washes. There is a risk of material damage. Deactivate Automatic Hold before driving into the car wash.

Overview

Button in the vehicle

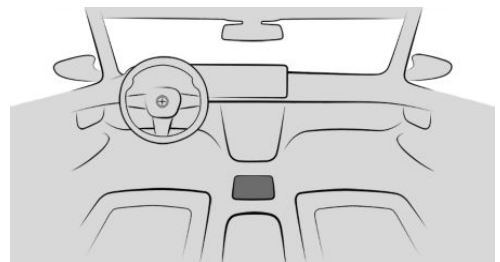

AUTO H

Automatic Hold

Activating the Automatic Hold function

1. Switch on drive-ready state.



2. Press the button.

The LED is illuminated.



The indicator light illuminates green.

Automatic Hold is ready to operate.

When the vehicle is restarted, the last selected setting is retained.

Automatic Hold holds the vehicle

The function is activated and the driver's door is closed.



Once the vehicle has stopped, it is automatically secured from rolling once the indicator light illuminates green.

Driving off

To drive off, press the accelerator pedal.

The brake is released automatically and the parking brake indicator light is extinguished.

Automatic activation of the parking brake

The parking brake is applied automatically if drive-ready state is switched off or the vehicle is exited while Automatic Hold is holding the vehicle.



The indicator light changes from green to red.

The parking brake is not applied automatically if drive-ready state was switched off while the vehicle was rolling to a stop. Automatic Hold is temporarily deactivated in this case.

Deactivating operational readiness



Press the button.

The LED is extinguished.



The indicator light extinguishes.

Automatic Hold is deactivated.

If the vehicle is being held by Automatic Hold, also depress the brake when deactivating.

Turn indicator

Turn indicator in exterior mirror

Do not fold in the exterior mirrors while driving or while operating the turn indicators or hazard warning lights to ensure that the indicator lamps in the exterior mirrors are well recognisable.

Indicating

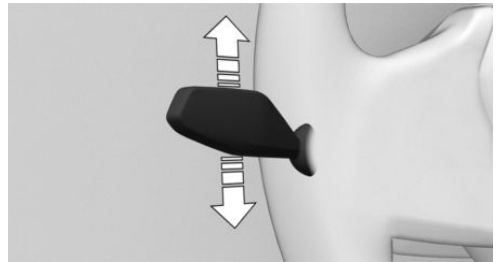

Press the lever beyond the resistance point.

One-touch signalling

Briefly tap the lever up or down.

The duration of the one-touch signalling can be set.

1. "MENU"
2. "Vehicle apps"
3. "Exterior lighting"
4. If necessary, "Additional settings"

5. "One-touch indicator"
6. Select the desired setting.

Indicating a turn briefly

Press the lever as far as the resistance point and hold it there for as long as you wish to indicate a turn.

High-beam headlight, headlight flasher

Press the lever forwards or pull it back.



- ▷ High-beam headlight on, arrow 1.
The high-beam headlight is illuminated when the low-beam headlight is switched on.
- ▷ High-beam headlight off/headlight flasher, arrow 2.



The indicator light in the instrument cluster is illuminated when the high-beam headlight is switched on.

Wiper system

General

Do not use the wipers on a dry windscreen, otherwise the wiper blades will wear or become damaged more quickly.

Safety notes

WARNING

If the wipers start moving when they are folded away from the windscreen, parts of the body may become trapped or the vehicle may be damaged. There is a risk of injury or material damage. Make sure that the vehicle is switched off when the wipers are folded away from the windscreen, and that the wipers are in contact with the windscreen when switching on.

NOTE

If the wipers are frozen to the windscreen, switching them on may cause the wiper blades to tear off and the wiper motor to overheat. There is a risk of material damage. Defrost the windscreen before switching on the wipers.

Switching on the wiper system

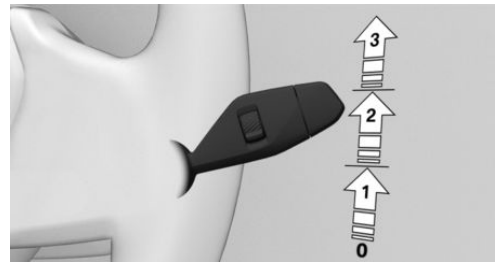

Press the lever upwards to the desired position.

- ▷ Rest position of the wipers, position 0.
- ▷ Rain sensor, position 1.
When the vehicle is at a standstill, the wipers switch to intermittent mode.
- ▷ Normal wiper speed, position 2.
When the vehicle is at a standstill, the wipers switch to normal speed.
- ▷ Fast wiper speed, position 3.
When the vehicle is at a standstill, the wipers switch to normal speed.

If a journey is interrupted with the wiper system switched on: when the journey is resumed, the

wipers continue operating at the previous setting.

Switching off the wiper system and flick wiping

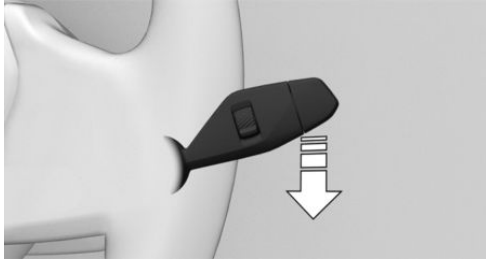

Press the lever down.

- ▶ To switch off: press lever downwards until position 0 is reached.
- ▶ To flick wipe: press the lever downwards from position 0.

The lever returns to position 0 when released.

Rain sensor

Principle

The rain sensor automatically controls the wiper operation depending on the rain intensity.

General

The sensor is mounted on the windscreen, directly in front of the interior mirror.

Safety note

NOTE

In car washes, the wipers may inadvertently start moving if the rain sensor is activated. There is a risk of material damage. Deactivate the rain sensor in car washes.

Activating the rain sensor

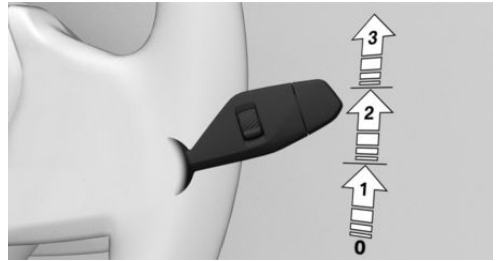

Press the lever upwards once from position 0, arrow 1.

Wiping is started.

The LED in the wiper lever is illuminated.

If there is frost, wiping may not start.

Deactivating the rain sensor

Press the lever back to position 0.

Setting the sensitivity of the rain sensor

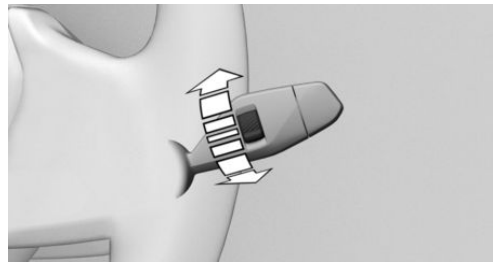

Turn the knurled wheel to set the sensitivity of the rain sensor.

Upwards: high sensitivity of the rain sensor.

Downwards: low sensitivity of the rain sensor.

Window washer system

Safety notes

⚠ WARNING

At low temperatures, the washer fluid can freeze onto the windscreen and restrict visibility. There is a risk of accident. Only use the washer systems if there is no possibility of the washer fluid freezing. Use antifreeze if required.

⚠ NOTE

If the washer fluid reservoir is empty, the washer pump cannot operate as intended. There is a risk of material damage. Do not use the washer system with the washer fluid reservoir empty.

Cleaning the windscreen

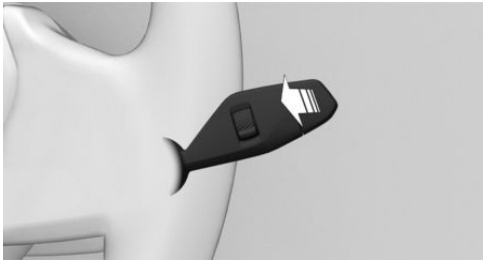

Pull the lever.

Washer fluid is sprayed onto the windscreen directly in front of the wiper blade as the wipers move up.

Fold-out position of the wipers

Principle

The wipers can be folded out from the windscreen in the fold-out position. This is necessary for example when replacing the wiper blades or to keep them away from the windscreen when there is frost.

Safety notes

⚠ WARNING

If the wipers start moving when they are folded away from the windscreen, parts of the body may become trapped or the vehicle may be damaged. There is a risk of injury or material damage. Make sure that the vehicle is switched off when the wipers are folded away from the windscreen, and that the wipers are in contact with the windscreen when switching on.

⚠ NOTE

If the wipers are frozen to the windscreen, switching them on may cause the wiper blades to tear off and the wiper motor to overheat. There is a risk of material damage. Defrost the windscreen before switching on the wipers.

Folding out the wipers

1. Switch on standby state.
2. Press the wiper lever down and hold until the wipers stop in an approximately vertical position.

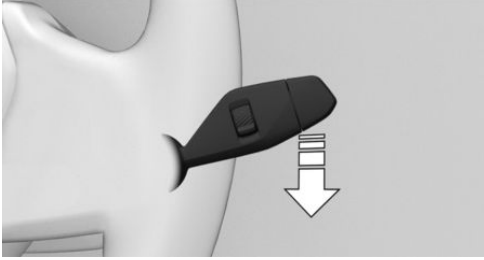

3. Lift the wipers completely away from the windscreen.



Folding in the wipers

1. Fold the wipers fully down onto the windscreen.
2. Switch on standby state and press and hold the wiper lever down again.
The wipers move back to the rest position and are operational once again.

Displays

Vehicle equipment

This chapter describes equipment, systems and functions which are offered or will be offered on a model-specific basis, even if they are not included in the vehicle in question.

For further information:

Vehicle equipment, see page 7.

Instrument cluster

Principle

The instrument cluster is a variable display. The displays and the layout adjust to the respective drive mode.

General

The displays in the instrument cluster can sometimes differ from the illustrations in the Owner's Handbook.

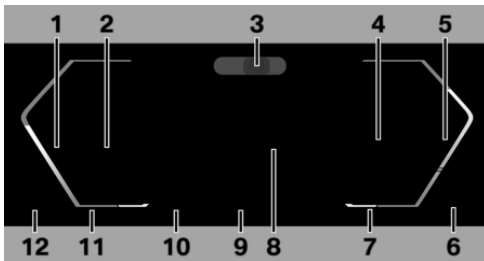

Overview



- 1 Speedometer
- 2 Driver assistance systems [224](#)
- 3 Driver Attention Camera [218](#)
- 4 Selection lists [170](#)
Using eDRIVE efficiently [311](#).
Check Control [156](#)

- 5 Power display [163](#)
- 6 Range [165](#)
- 7 Selector lever position [137](#)
Outside temperature [165](#)
- 8 Central display area, configurable [153](#)
Navigation display
Charge display [155](#)
Digital speed
Trip odometer, see Trip data [171](#)
- 9 Drive mode [144](#)
- 10 Speed Limit Assist [237](#)
Speed Limit Info [167](#)
- 11 Time [165](#)
- 12 Charging status display of the high-voltage battery [163](#)

Operating elements on the steering wheel

Operating element	Function
	Display menu bar in the instrument cluster: press button.
	Selection to the left or right: press the corresponding arrow key.
	Selection up or down: turn knurled wheel. Confirm selection: press knurled wheel.

Configuring the central display area

The contents for the central display area in the instrument cluster can be individually configured

and displayed, for example, the display of trip data.

1.  Press the button on the steering wheel.
A menu bar is displayed in the instrument cluster.
2. "CONTENT"
If applicable, select the menu via the arrow buttons.
3. Using the knurled wheel, select the desired setting:
 - ▷ Reduced display.
 - ▷ Trip data.
 - ▷ Assisted View.
 - ▷ With navigation system: route preview.
 - ▷ With navigation system: map view.
 - ▷ Entertainment.

Some contents for the central display area can also be configured as a view in the Head-up display.

For further information:

Head-up display, see page 174.

Configuring the layout

In COMFORT drive mode, the layout can be individually configured and displayed in the instrument cluster.

1.  Press the button on the steering wheel.
A menu bar is displayed in the instrument cluster.
2. "LAYOUT"
If applicable, select the menu via the arrow buttons.
3. Select the required setting via the knurled wheel.

Settings

Individual displays in the instrument cluster can be adjusted individually via iDrive, for example, a second actual speed.

1. "MENU"
2. "Vehicle apps"
3. "Displays"
4. "Instrument cluster"
5. Select the desired setting.

Assisted View

Principle

Depending on the equipment and if driver assistance is active, information about the driver assistance systems appears in an animated vehicle environment.

General

Depending on the settings, information on active Driver Assistance can be displayed permanently or temporarily in the instrument cluster.

Safety note

WARNING

The system does not relieve you of your personal responsibility to assess the visibility conditions and traffic situation correctly. There is a risk of accident. Adapt your driving style to the traffic conditions. Observe the traffic situation and intervene actively if the situation warrants it.

Permanent display

The information for the driver assistance can be configured permanently in the central display area of the instrument cluster.

For further information:

Configuring the central display area, see page [153](#).

Temporary display

1. "MENU"
2. "Vehicle apps"
3. "Displays"
4. "Instrument cluster"
5. "Display Assisted View when driver assistance is active"

Display

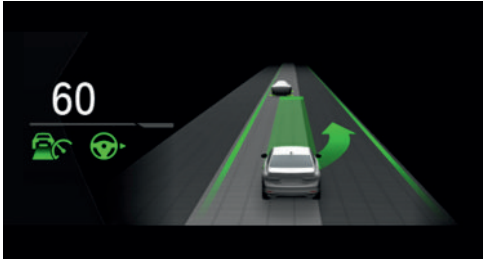

An example with active driver assistance: the indicator and warning lights for the distance control and the Lane Change Assistant indicate a lane change to the next lane. At the same time, the lane change to the next lane is shown with animation in the Assisted View.

System limits

The detection capability of the system is limited. Only objects detected by the system are taken into account.

The system may indicate something wrong.

For further information:

- ▷ Cameras, see page [47](#).
- ▷ Radar sensors, see page [48](#).

Charge display

Principle

The charging screen displays information about the charging process in the instrument cluster.

General

The displays in the instrument cluster can sometimes differ from the illustrations in the Owner's Handbook.

For further information:

Charging the vehicle, see page [316](#).

Overview

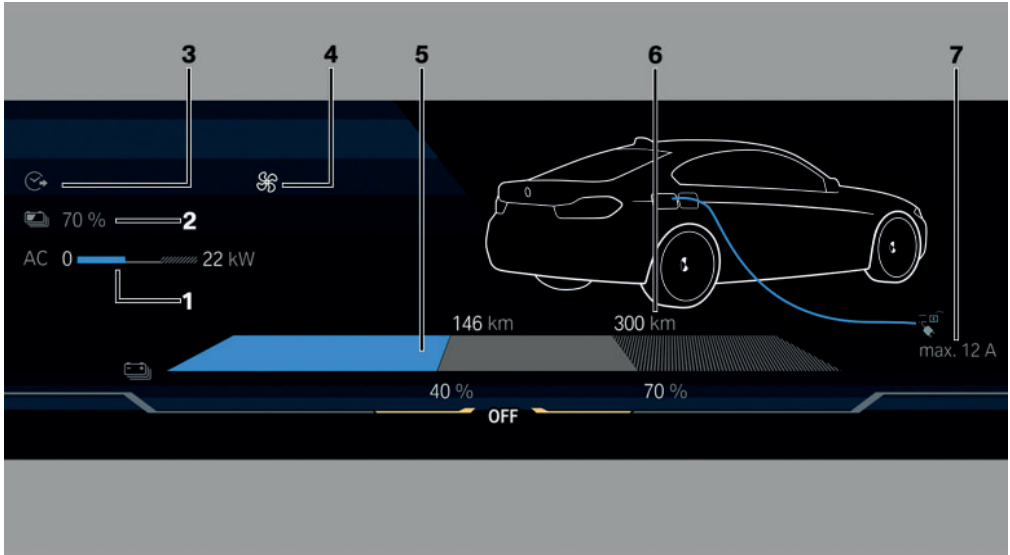

- | | |
|--|--|
| <ul style="list-style-type: none"> 1 Current charging power 324 2 Set target charge 324 3 Set departure time 325
Time for end of charging 324 4 Air conditioning 325 | <ul style="list-style-type: none"> 5 Current range 324
Current state of charge 324 6 Range when reaching the charging destination 324 7 Set or maximum current limitation 316 |
|--|--|

Check Control

Principle

Check Control monitors vehicle functions and alerts you to any faults in the monitored systems.

General

A Check Control message is displayed as a combination of indicator or warning lights and text messages in the instrument cluster and, if applicable, in the Head-up display.

An acoustic signal may also be output and a text message shown on the control display.

Hiding Check Control messages

 To hide Check Control messages, press the left arrow button on the steering wheel.

Continuous display

Some Check Control messages are displayed permanently and remain until the fault has been repaired. If a number of malfunctions have occurred at the same time, the messages are displayed in succession.

The messages can be hidden for approximately 8 seconds. Afterwards they are displayed again automatically.

Temporary display

Some Check Control messages are automatically hidden after approximately 20 seconds. The Check Control messages remain stored and can be displayed again.

Displaying saved Check Control messages

1. "MENU"
2. "Vehicle apps"
3. "Live Vehicle"
4. "Content"
5. "Vehicle status"
6.  "Check Control"
7. Select a text message.

Display

Check Control



At least one Check Control message is displayed or saved.

Text messages

Text messages and an icon in the instrument cluster explain what a Check Control message means and what the indicator and warning lights signify.

Supplementary text messages

Additional information, for example the cause of the fault and any action required, can be called up via Check Control.

With urgent text messages, the added text will be automatically displayed on the control display.

It is possible to select additional assistance depending on the Check Control message.

1. "MENU"
2. "Vehicle apps"
3. "Live Vehicle"
4. "Content"

5. "Vehicle status"
6.  "Check Control"
7. Select the required text message.
8. Select the desired setting.

Messages displayed at the end of the journey

Certain messages displayed when driving are displayed again when drive-ready state is switched off.

Indicator and warning lights

Principle

Indicator and warning lights in the instrument cluster display the status of some functions in the vehicle. Indicator and warning lights indicate faults in monitored systems.

General

Indicator and warning lights can illuminate in a variety of combinations and colours.

When switching on drive-ready state, the functionality of some lights is checked and they illuminate briefly.

Red lights

Acoustic seat belt warning



Seat belt is not buckled.

For further information:

Acoustic seat belt warning, see page 115.

Airbag system



The indicator light illuminates briefly; this indicates that the entire airbag system and seat belt tensioners are operational when the vehicle is switched on.

The indicator light illuminates continuously: there is a malfunction. Have the vehicle checked immediately by a Service Partner of the manufacturer or another qualified Service Partner or a specialist workshop.

For further information:

Airbags, see page [186](#).

Parking brake



The parking brake is engaged.

For further information:

Parking brake, see page [145](#).

Brake system



Fault in the brake system, braking power assistance may be faulty. Continue driving at moderate speed. Avoid abrupt

braking, take longer stopping distance into account.

Have the vehicle checked immediately by a Service Partner of the manufacturer or another qualified Service Partner or a specialist workshop.

Collision Warning with braking function



Indicator light illuminates: advance warning. Brake and increase the distance.

Indicator light flashes and an acoustic signal sounds: acute warning. Brake and take avoidance manoeuvre if necessary.

For further information:

Collision Warning with braking function, see page [195](#).

Crossroads Warning with city braking function



Risk of collision with crossing vehicle from right.



Risk of collision with crossing vehicle from left.



Indicator light illuminates: risk of collision with a vehicle with unidentifiable direction of travel or advance warning of vehicles crossing your own direction of travel.

The driver must intervene personally, for example by braking.

Indicator light flashes and an acoustic signal sounds: acute warning of vehicles crossing your own direction of travel.

Brake and take avoidance manoeuvre if necessary.

For further information:

Crossroads Warning with city braking function, see page [197](#).

Pedestrian Warning with city braking function



Indicator light is illuminated and an acoustic signal sounds: imminent collision with a detected pedestrian or a cyclist.

Take action yourself immediately by braking or swerving.

For further information:

Pedestrian Warning with city braking function, see page [196](#).

Cruise Control with distance control



Indicator light flashes and an acoustic signal sounds: brake and take avoidance manoeuvre, if necessary.

For further information:

Active Cruise Control with distance control, see page [229](#).

Steering and Lane Control Assistant



Indicator light flashes and an acoustic signal sounds: the system is switching off.

For further information:

Steering and Lane Control Assistant, see page [241](#).

Yellow lights

Steering and Lane Control Assistant



Indicator light illuminates and an acoustic signal may sound: a system interruption is imminent.

Indicator light flashing: lane boundary has been driven over.

For further information:

Steering and Lane Control Assistant, see page [241](#).

Anti-lock Braking System ABS



Avoid sudden braking. Bear in mind that stopping distances will be longer.

System failure. Ease of steering is restricted during emergency braking.

Have the vehicle checked immediately by a Service Partner of the manufacturer or another qualified Service Partner or a specialist workshop.

Front-collision warning



Depending on the national-market version: the system is restricted or failed.



Depending on the national-market version: the system is deactivated.

For further information:

Front-collision warning, see page [192](#).

Dynamic Stability Control



Indicator light flashes: Dynamic Stability Control controls the drive and brake forces. The vehicle is being stabilised.

Decrease speed and adjust driving style to the road conditions.

Indicator light is illuminated: Dynamic Stability Control malfunction or initialising. No driving stabilisation.

Have the system checked immediately by a Service Partner of the manufacturer or another qualified Service Partner or a specialist workshop.

For further information:

Dynamic Stability Control, see page [220](#).

Dynamic Stability Control deactivated or Dynamic Traction Control activated



Dynamic Stability Control is deactivated or Dynamic Traction Control is activated.

For further information:

▷ Dynamic Stability Control, see page [220](#).

▷ Dynamic Traction Control, see page [222](#).

Flat tyre monitor (RPA)



Flat tyre monitor (RPA) reports a tyre pressure loss in a tyre.

Reduce your speed and carefully stop the vehicle. Avoid heavy braking and sudden steering manoeuvres.

For further information:

Flat tyre monitor (RPA), see page [345](#).

Tyre Pressure Monitor



Indicator light illuminates: the Tyre Pressure Monitor is reporting a low tyre inflation pressure or a flat tyre. Note the information in the Check Control message.

Indicator light flashes and then illuminates continuously: the system is unable to detect flat tyres or tyre pressure losses.

▷ Fault due to systems or devices with the same radio frequency: the system is auto-

matically reactivated upon leaving the field of interference.

- ▷ For tyres with special approval: the Tyre Pressure Monitor was unable to complete the reset. Reset the system again.
- ▷ A wheel without wheel electronics is mounted: if necessary have it checked by a Service Partner of the manufacturer or another qualified Service Partner or a specialist workshop.
- ▷ Malfunction: have the system checked by a Service Partner of the manufacturer or another qualified Service Partner or a specialist workshop.

For further information:

Tyre Pressure Monitor, see page 338.

Steering system



The steering system may be faulty.

Have the system checked by a Service Partner of the manufacturer or another qualified Service Partner or a specialist workshop.

Lane Departure Warning



Depending on the national-market version: the system is restricted, deactivated or has failed.

For further information:

Lane Departure Warning, see page 199.

Lane Change Warning



Depending on the national-market version: the indicator light illuminates, if applicable, in combination with a Check

Control message: the system is restricted or has failed.



Depending on the national-market version: the system is switched off.

For further information:

Lane Change Warning, see page 202.

Rear fog light



Rear fog light is switched on.

For further information:

Rear fog light, see page 183.

Acoustic pedestrian protection



Acoustic protection for pedestrians has failed. Increased caution when manoeuvring.

In case of repeated malfunctions, have the system checked by a manufacturer Service Partner or another qualified Service Partner or specialist workshop.

For further information:

Acoustic pedestrian protection, see page 136

Charging capacity restricted



For further information:

Charging the vehicle, see page 316.

Green lights

Turn indicators



The turn indicator is switched on.

If the indicator light flashes more rapidly than usual, a turn indicator bulb has failed.

For further information:

Turn indicators, see page 148.

Side lights



The side lights are switched on.

For further information:

Side light, low-beam headlight and parking light, see page 178

Low-beam headlight



The low-beam headlight is switched on.

For further information:

Side light, low-beam headlight and parking light, see page [178](#)

High-beam Assistant



Low-beam headlight is switched on and the High-beam Assistant is activated.

The high-beam headlight is switched on and off automatically according to traffic situation.

For further information:

High-beam Assistant, see page [182](#).

Lane Departure Warning



Depending on the national-market version: indicator light illuminates: a lane boundary has been detected on at least one side of vehicle and warnings can be issued.

Indicator light flashes: the vehicle is going to drive across the lane boundary.

For further information:

Lane Departure Warning, see page [199](#).

Lane Change Warning



Depending on the national-market version: the system is switched on. Warnings and, if necessary, steering interventions can occur within the system limits.

For further information:

Lane Change Warning, see page [202](#).

Automatic Hold



Automatic Hold is ready to operate. The vehicle is held automatically when at a standstill.



The function is activated and the driver's door is closed. The vehicle is automatically secured against rolling after stopping.

For further information:

Automatic Hold, see page [147](#).

Manual Speed Limiter



Indicator light illuminates: the system is switched on.

Indicator light flashes: set speed limit is exceeded.

For further information:

Manual Speed Limiter, see page [224](#).

Cruise Control



The system is active.

For further information:

Cruise Control, see page [226](#).

Cruise Control with distance control



Indicator light illuminates: system has detected a vehicle ahead. The vehicle icon goes out if no vehicle in front is detected.

Indicator light flashes: vehicle in front has driven off.

For further information:

Active Cruise Control with distance control, see page [229](#).

Speed Limit Assist



The detected speed limit can be applied with the SET button. As soon as the speed limit has been adopted, a green tick is displayed.

For further information:

Speed Limit Assist, see page [237](#).

Steering and Lane Control Assistant



The system is activated and assists in keeping the vehicle in the driving lane.

For further information:

Steering and Lane Control Assistant, see page [241](#).

Lane Change Assistant



Green arrow icon for lane-changing: the system is carrying out a lane change.



Grey line for lane marking on the appropriate side: the system has detected the lane change request. Lane change not currently possible.



Depending on the national-market version:

Grey arrow icon for lane-changing: lane change not possible; operating requirements not met.

For further information:

Lane Change Assistant, see page [246](#).

Assisted Driving Plus



The system is active.

For further information:

Assisted Driving Plus, see page [244](#).

Blue lights

High-beam headlight



The high-beam headlight has been switched on.

For further information:

- ▶ High-beam headlight, see page [149](#).
- ▶ High-beam Assistant, see page [182](#).

Grey lights

Cruise Control with distance control



Indicator light flashes: the requirements for operation of the system are no longer being met. The system has been deactivated but will continue to brake until you actively take over by depressing the brake or accelerator pedal.

For further information:

Active Cruise Control with distance control, see page [229](#).

Steering and Lane Control Assistant



System is on standby and does not make any steering wheel movement.

The system activates automatically when all operating requirements are met.

For further information:

Steering and Lane Control Assistant, see page [241](#).

Assisted Driving Plus



The system is interrupted and activates automatically as soon as all functional requirements are met.

For further information:

Assisted Driving Plus, see page [244](#).

White lights

Cruise Control with distance control



No display of distance control as the accelerator pedal is being pressed.

For further information:

Active Cruise Control with distance control, see page [229](#).

Assisted Driving Plus



The system is ready.

For further information:

Assisted Driving Plus, see page [244](#).

Charging status display

Safety note

WARNING

Even when the display shows that the high-voltage battery is discharged, the high-voltage system will still be carrying high-voltage. There is a risk of injury or fire. Do not touch or modify live parts, for example orange high-voltage cables, even if the batteries are empty.

Display



With turned on standby state and drive-ready state, the available battery charge state of the high-voltage battery is continuously displayed in percent in the instrument cluster.

An arrow next to the battery icon indicates the vehicle side on which the charging socket flap is located.

In case of temperature fluctuations, the battery charge state may change.

Power display

Principle

The power display indicates the currently drawn drive power as a percentage of the overall power.

General

The available drive power may be reduced due to the following factors:

- ▶ Heavily discharged high-voltage battery.
- ▶ Extreme outside temperatures.
- ▶ Prolonged or high-power driving, for example, with a sporty driving style or uphill driving.
- ▶ Depending on the equipment and national-market version: drive power limitation is defined with the BMW Digital Key.

The grey ePOWER area is automatically adjusted.

Icons in the power display indicate if the drive power has been reduced.

Example icon	Description
	Reduced drive power due to cold drivetrain.
	Reduced drive power due to increased drive temperature. A Check Control message is shown where applicable.

The intensity of the energy recuperation depends on the energy recuperation settings.

For further information:

- ▶ BMW Digital Key, see page [96](#).
- ▶ Increasing the range, see page [309](#).
- ▶ Driving in detail: eDRIVE, see page [141](#).

Display

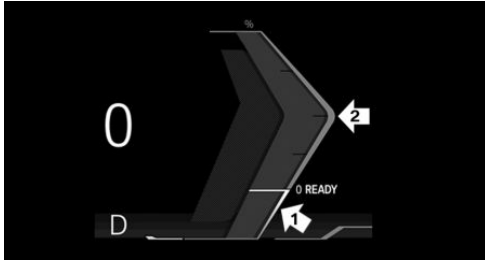

In COMFORT and ECO PRO drive modes:

Pointer in the area of arrow 1: display of the energy recuperation achieved when rolling to a stop or when decelerating.

Pointer in the area of arrow 2: power as a percentage.

Recuperation display

Depending on the setting for the recuperation, the display in the power display will change.

Icon	Meaning
	Low energy recuperation. Selector lever position D is engaged.
	Medium energy recuperation. Selector lever position D is engaged.
	High energy recuperation. Selector lever position D or B is engaged.
	Adaptive recuperation is activated. Adaptive recuperation, see page 313.

SPORT BOOST display



In SPORT BOOST drive mode, increased power can be temporarily accessed, for example for very fast acceleration during overtaking.

The availability of the increased power, Boost, is displayed in the instrument cluster.

Display	Meaning
White	More power is available but has not yet been accessed.
Blue	More power is being accessed. When accessed, the Boost display empties accordingly.
Grey	More power is not available, for example if the drivetrain is cold.

For further information:

Driving Experience Control, see page 144.

Standby state and drive-ready state



OFF in the instrument cluster indicates that drive-ready state is switched off and standby state is switched on.



READY indicates drive-ready state.

For further information:

Vehicle operating condition, see page 51.

Date and time

Various settings can be configured for the display of date and time, for example the date format.

Depending on the equipment and national-market version, the time zone can be set and the automatic time setting can be activated. The automatic time setting automatically updates the time, date and, if necessary, the time zone.

1. "MENU"
2. "Vehicle apps"
3. "System settings"
4. "Date and time"
5. Select the desired settings.

Selecting the units of measurement

Depending on the national-market version, it is possible to select the units of measurement for various values, for example, consumption, distances and temperature.

1. "MENU"
2. "Vehicle apps"
3. "System settings"
4. "Units"
5. Select the desired menu item.
6. Select the desired setting.

Outside temperature

General

If the display drops to +3 °C/+37 °F or lower, a signal sounds.

A Check Control message is shown.

There is an increased risk of black ice.

Safety note

WARNING

Even at temperatures above +3 °C/+37 °F there may be an increased risk of black ice, for example on bridges or on shaded sections of road. There is a risk of accident. At low temperatures, adjust driving style to the weather conditions.

Range

General

The anticipated range for the energy stored in the high-voltage battery is permanently displayed in the instrument cluster.

Always ensure that the range is sufficient for the planned trip. The range is dynamic and may change abruptly.

The range can be reduced or increased based on the following factors:

- ▷ Driving style.
- ▷ Traffic conditions.
- ▷ Driving mode change.
- ▷ Climate and terrain conditions.
- ▷ Settings of the automatic air conditioning.
- ▷ After a route has been calculated by the navigation system, depending on the route profile, the route length and the selected speed.
- ▷ When leaving a route or recalculating a route.

Information about the current range can be displayed in the instrument cluster.

Check Control messages alert you when the range is low.

For further information:

► Increasing the range, see page 309.

Display



The range is continuously displayed in the instrument cluster.

Range with active route guidance

📍 The icon is displayed next to the range when a route guidance was started in the navigation system. Information from the navigation system is taken into account for the calculation of the current range.

Heavily discharged high-voltage battery



High-voltage battery is heavily discharged. The drive power is reduced. Heating and air conditioning functions are disabled.

In this state, an exact calculation of the range is no longer possible. A low range may be available depending on the environmental conditions.

Re-activating the drive-ready state can help to increase the range slightly, for example to move the vehicle from a danger area.

Charge state with widely fluctuating temperatures

If there are significant temperature fluctuations and the charge level of the high-voltage battery is low, it might no longer be possible to start the vehicle for the next trip. Recharge the vehicle in good time if the charge state is low.

Service requirements

Principle

The function shows the current service requirements and related maintenance jobs.

General

The distance or time remaining until the next service is displayed briefly in the instrument cluster after drive-ready state is switched on.

The current service requirements can be read out from the vehicle key by a service advisor.



Display

Detailed information on service requirements

More detailed information on the maintenance work required can be displayed on the control display.

1. "MENU"
2. "Vehicle apps"
3. "Live Vehicle"
4. "Content"
5. "Vehicle status"
6.  "Service requirements"
Maintenance routines and any statutory inspections required are displayed.
7. Select an entry to display more detailed information.

Icons

Icon	Description
	No service is currently needed.
	Maintenance or a statutory inspection is due soon.
	Service interval has been exceeded.

Entering deadlines

Dates for mandatory vehicle inspections can be entered.

Ensure that the date and time are set correctly in the vehicle.

1. "MENU"
2. "Vehicle apps"
3. "Live Vehicle"
4. "Content"
5. "Vehicle status"
6.  "Service requirements"
7. "Vehicle inspection"
8. "Date:"
9. Select the desired setting.

Service history



Principle

Completed maintenance work can be displayed on the control display.



General

Have maintenance work performed by a Service Partner of the manufacturer or another qualified Service Partner or a specialist workshop. The maintenance work carried out is entered in the vehicle data. The function is available as soon as a maintenance visit has been logged in the vehicle data.

Displays

1. "MENU"
2. "Vehicle apps"
3. "Live Vehicle"
4. "Content"
5. "Vehicle status"
6.  "Service requirements"
Essential maintenance routines and any statutory inspections required are displayed.
7.  "Service history"
8. Select an entry to display more detailed information.

Icons

Icon	Description
	Maintenance has been carried out on time.
	Maintenance has been carried out later than scheduled.
	Maintenance has not been carried out.

Speed Limit Display with no-overtaking indicator

Speed Limit Info

Principle

Speed Limit Info shows the currently valid speed limit in the instrument cluster and, if necessary, the Head-up display and possibly supplementary signs.

General

The camera located near the interior mirror detects road signs at the edge of the road as well as variable overhead signs.

Depending on the national-market version, road signs with supplementary signs, for example, for wet road conditions, are considered and compared with the vehicle's onboard data, for example, the windscreen wiper signal. The road sign and associated supplementary signs are then displayed in the instrument cluster and the Head-up display, if applicable, or ignored, depending on the situation. Some supplementary signs are taken into account in the speed limit evaluation, but are not displayed in the instrument cluster.

If a navigation system is installed, the system takes the information saved in the navigation system into account where applicable and also displays the speed limits for sections of road with no road signs.

Speed limits for trailer operation are displayed when the trailer socket is occupied or when the trailer operation has been activated via iDrive.

For further information:

Trailer operation, see page 303.

No-overtaking indicator

Principle

Overtaking restriction signs and end of restriction signs which have been detected by the camera are indicated by corresponding icons in the instrument cluster and, if applicable, the Head-up display.

General

The system considers overtaking restrictions and ends of restrictions that are indicated by means of road signs.

It will not display anything in the following situations:

- ▶ In countries where overtaking restrictions are primarily shown by road markings.
- ▶ On routes without road signs.
- ▶ In the case of railway crossings, lane markings and other situations which indicate an

overtaking restriction but which are not sign-posted to this effect.

Overtaking restrictions for trailer operation are not shown.

Depending on the equipment, an additional icon with distance information may also be displayed to indicate the end of the no-overtaking indicator.

Safety note

WARNING

The system does not relieve you of your personal responsibility to assess the visibility conditions and traffic situation correctly. There is a risk of accident. Adapt your driving style to the traffic conditions. Observe the traffic situation and intervene actively if the situation warrants it.

Sensors

The system is controlled by the camera behind the windscreen.

Displaying Speed Limit Info

General

The Speed Limit Info can be shown or hidden via iDrive in the instrument cluster. Depending on the national-market version, Speed Limit Info is continuously displayed in the instrument cluster.

Displaying Speed Limit Info





1. "MENU"
2. "Vehicle apps"
3. "Driving settings"
4. "Driver assistance"
5. "Driving"
6. "Speed Assistant"
7. "Speed limits"
8. "Show current limit"

Display



General

Depending on the national-market version, supplementary signs and no-overtaking indicators are displayed together with Speed Limit Info.



Speed Limit Info





Icon	Description
	Present speed limit.
	The display may vary depending on the equipment.
	No data for the current speed limit available.
	Speed Limit Info unavailable.

No-overtaking indicator

Icon	Description
	No overtaking.
	End of overtaking restriction.

Supplementary signs

Icon	Description
	Speed limit with time limit.
	Speed limit only applies in wet conditions.
	Speed limit only applies in snowy conditions.

Icon	Description
	Speed limit only applies in foggy conditions.
	Speed limit applies to exit on left.
	Speed limit applies to exit on right.
	Speed limit only applies when towing a trailer.

Speed Limit Display with Anticipatory Indicator

Depending on the equipment and national-market version, an additional icon with distance information may indicate that a change in speed limit is ahead. The Anticipatory Indicator must be activated for Speed Limit Assist.

Temporary speed limits may also be displayed, for example at construction sites. Temporary speed limits can only be displayed if the following services are selected in the data protection menu for the navigation system:

- ▷ "Learning map"
- ▷ "Map update"

For further information:

- ▷ Speed Limit Assist, see page 237.
- ▷ Data protection, see page 70.

Settings

1. "MENU"
2. "Vehicle apps"
3. "Driving settings"
4. "Driver assistance"
5. "Driving"
6. "Speed Assistant"
7. Select the desired setting:
 - ▷ "Warning when speeding": activate or deactivate the flashing of the Speed Limit Info display in the instrument cluster and,

if applicable, the Head-up display when the currently applicable speed limit is exceeded. The warning given when a speed limit is exceeded may depend on the Speed Limit Assist settings.

- ▶ "Show excess speed": the speed limit detected by the Speed Limit Info is indicated by a mark on the speedometer.

System limits

System limits of the sensors

For further information:

- ▶ Camera, see page 47.

Functional limitations

Functionality may be restricted or incorrect information may be displayed in some situations such as:

- ▶ Road signs are fully or partially concealed by objects, stickers or paint.
- ▶ Road signs do not correspond to the standard.
- ▶ In areas not covered by the navigation system.
- ▶ In the case of navigation data that is invalid, outdated or not available.
- ▶ If there are navigation discrepancies, for example due to changes in road layout.
- ▶ If the vehicle is too close to the vehicle ahead.
- ▶ When overtaking buses or trucks with road sign stickers.
- ▶ If there are electronic road signs.
- ▶ If road signs are detected that apply to a parallel road.
- ▶ If the road signs or road layouts are specific to one country.

Selection lists

Principle



The instrument cluster or the Head-up display can show lists for certain functions and can be used for operation where applicable.

- ▶ Entertainment source.
- ▶ Current audio source.
- ▶ Recent calls list.

If applicable, the relevant menu is opened on the control display.

Displaying and using the list

The selection lists can be displayed and operated using the operating elements on the steering wheel.

Operating elements	Function
	To display the entertainment list: turn the knurled wheel. To select up or down in the list: turn the knurled wheel. Confirm selection: press knurled wheel.
	To change the entertainment source: press the corresponding arrow key.
	Display last calls list: press the button.

Display

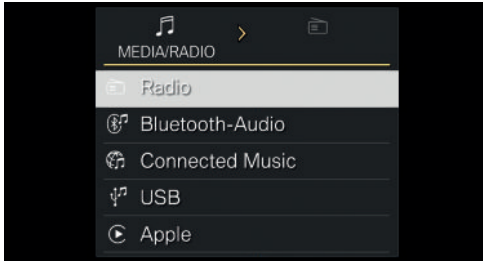

An example:

To change the track or entertainment source after calling up the entertainment list, use the arrow keys on the steering wheel. Press the knurled wheel to confirm the selection.

Turn the knurled wheel up or down to select the desired entry in the list. Press the knurled wheel to confirm the selection.

Depending on the equipment, the list in the instrument cluster may differ from the illustration.

Live Vehicle

Principle

In the Live Vehicle menu, appropriate information is shown on the control display depending on the driving situation and drive mode set.

General

The centre of the display is the virtual picture of your own vehicle, which shows the current state of the vehicle, for example, an open door. Fault statuses are not taken into account.

In the Live Vehicle menu, it is possible to choose between an adaptive display with changing content and static content.

Adaptive content

The following is displayed in alternating order and, if applicable, depending on the selected drive mode:

- ▷ Vehicle status, see page 174.
- ▷ Current driving condition, see page 173.
- ▷ Sport displays, see page 174.
- ▷ Driving style analysis, see page 312.
- ▷ Trip data, see page 171.

Static content

The following content can be displayed continuously on the control display regardless of the driving situation and set drive mode

- ▷ Vehicle status.
- ▷ Trip data.

Configuring the display

1. "MENU"
2. "Vehicle apps"
3. "Live Vehicle"
4. "Content"
5. Select the desired setting.
 - ▷ "Adaptive content": different contents are displayed in varying order.
 - ▷ "Journey data": trip data is permanently displayed.
 - ▷ "Vehicle status": vehicle status is permanently displayed.

Trip data

Principle

Values for the trip, for example, the average consumption or trip distance, are displayed.

General

The trip data can be shown on the control display and in the instrument cluster.

Depending on the setting in the Live Vehicle menu, the trip data is shown dynamically or continuously on the control display.

The values can be displayed and reset depending on different intervals.

Display on the control display

Overview

Depending on the equipment, the following information is shown as a function of the set interval and drive mode:

- ▶ Set interval for displaying the trip data.
- ▶ Average consumption, depending on the set interval.
- ▶ Driving time depending on the configured interval.
- ▶ Route covered, depending on the set interval.
- ▶ Counter for energy recovery depending on the configured interval.

Displaying trip data continuously

1. "MENU"
2. "Vehicle apps"
3. "Live Vehicle"
4. "Content"
5. "Journey data"

Display in the instrument cluster

Information on consumption and distance covered can be displayed in the instrument cluster.

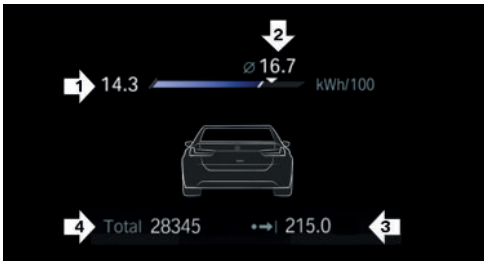

- ▶ Current consumption, arrow 1.
- ▶ Average consumption, arrow 2.

- ▶ Distance covered depending on the configured interval, arrow 3.
- ▶ Total kilometres, arrow 4.

Average consumption

The average consumption is calculated on the basis of various distances.

Current consumption

The current consumption displays the current energy consumption. It is possible to check how efficiently the vehicle is being driven.

Configuring the trip data display

The intervals for displaying the trip data in the instrument cluster and on the control display can be configured.

Use the key on the left steering column lever:

1. Press the key.
The trip data is displayed.

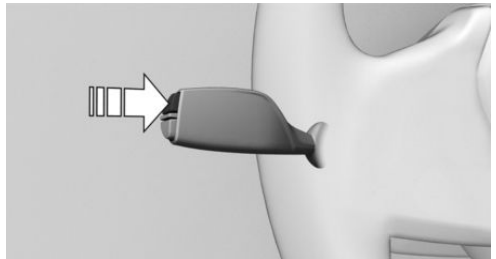

2. Press the key repeatedly until the desired setting is displayed.

Via iDrive:

1. "MENU"
2. "Vehicle apps"
3. "System settings"
4. "Time period for journey data"
5. "Values"
6. Select the desired setting:

- ▷ "Since start of journey ()": the values are reset automatically if the vehicle is at a standstill for approximately four hours.
- ▷ "Since last charge ()": the values are automatically reset after charging.
- ▷ "Since factory": the values since leaving the factory are displayed.
- ▷ "Since Individual ()": the values since the last manual reset are displayed. The values can be reset at any time.

Resetting average values manually

The following interval can be reset manually at any time: "Since Individual ()".

Use the key on the left steering column lever:

1. Press the key.
The trip data is displayed.

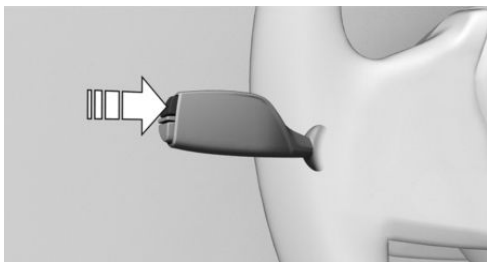

2. Press and hold the key to reset the average values.

Via iDrive:

1. "MENU"
2. "Vehicle apps"
3. "System settings"
4. "Time period for journey data"
5. "Reset Individual"

The average values and counters are reset. Once the average values and counters have been reset, the following interval is automatically activated: "Since Individual ()".

Current driving condition

General

The current driving condition is displayed dynamically while driving in the Live Vehicle menu on the control display.

The following conditions are displayed:

- ▷ Driving.
- ▷ Efficient rolling.
- ▷ Battery is charging.
- ▷ Adaptive recuperation is active.

For further information:

Adaptive recuperation, see page [313](#).

Operating requirements

- ▷ COMFORT or ECO PRO drive mode must be selected.
- ▷ The following settings must be selected for Live Vehicle: "Adaptive content"

Display

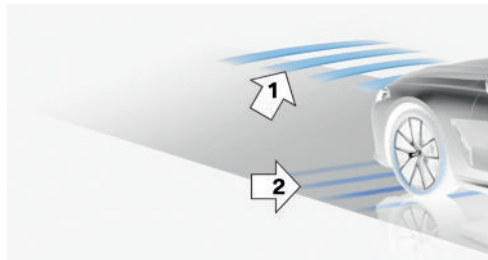

An example:

The adaptive recuperation is active, arrow 1.

The high-voltage battery is charged when the vehicle is decelerating, arrow 2.

Sport displays

Principle

The sport displays primarily assist a sporty driving style.

Operating requirements

- ▷ Drive mode SPORT must be selected.
- ▷ The following settings must be selected for Live Vehicle: "Adaptive content"

Display

The sport displays are displayed in the Live Vehicle menu on the control display.

The following information is displayed:

- ▷ Torque.
- ▷ Power.
- ▷ Electric motor rotational speed.
- ▷ Electric motor temperature.

Vehicle status

General





The status can be displayed and actions performed for several systems, such as for Check Control.

Depending on the setting in the Live Vehicle menu, the vehicle status is shown dynamically or continuously on the control display.

Displaying the vehicle status continuously

1. "MENU"
2. "Vehicle apps"
3. "Live Vehicle"
4. "Content"
5. "Vehicle status"

Overview

Icon	Description
	"Flat Tyre Monitor": status of the flat tyre monitor RPA, see page 345.
	"Tyre Pressure Monitor": status of the Tyre Pressure Monitor, see page 338.
	"Check Control": to display saved Check Control messages, see page 156.
	"Service requirements": to display service requirements, see page 166.

Head-up display

Principle

The driver is able to read and understand this information without having to divert attention from the road.

The Head-up display projects important information in the driver's field of view, for example the speed.

General

Follow the instructions on cleaning the head-up display in the Care chapter.

Overview

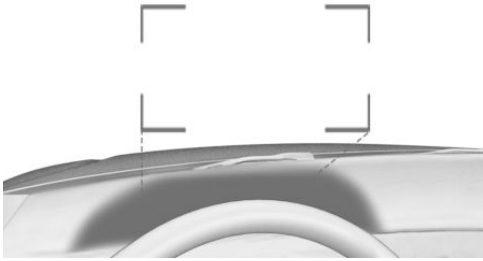

The protective glass of the head-up display is located between the steering wheel and the windscreen.

Configuring a view

Regardless of the display in the instrument cluster, different views can be set up for the Head-up display, for instance a reduced view.

1.  Press the button on the steering wheel.
A menu bar is displayed in the instrument cluster.
2. "HEAD-UP"
If applicable, select the menu via the arrow buttons.
3. Select the required setting via the knurled wheel.

Display

Turning the Head-up display on/off

1. "MENU"
2. "Vehicle apps"
3. "Displays"
4. "Head-up display"
5. "Head-up display"

Overview

The following information is displayed in the Head-up display:

- ▷ Speed.
- ▷ Navigation instructions.
- ▷ Check Control messages.
- ▷ Lists and messages.
- ▷ Driver assistance systems.

Some of this information is only shown briefly when needed.

Visibility of the display

The visibility of the information shown on the Head-up display can be affected by the following:

- ▷ Seat position.
- ▷ Objects on the protective glass of the head-up display.
- ▷ Dust or dirt on the protective glass of the head-up display.
- ▷ Dirt on the inside or outside of the windscreen.
- ▷ Sunglasses with certain polarisation filters.
- ▷ Wet roads.
- ▷ Adverse lighting conditions.

If the image is distorted, have the default settings checked by a Service Partner of the manufacturer or another qualified Service Partner or a specialist workshop.

Settings

Individual settings can be entered for the Head-up display, for example for the height, brightness or illustration. In addition, individual displays in the Head-up display can be set up separately, for instance information on driver assistance.

1. "MENU"
2. "Vehicle apps"
3. "Displays"

4. "Head-up display"
5. Select the desired setting.

Special windscreen

The windscreen is an integral part of the system.

The shape of the windscreen enables a sharp image to be projected.

A foil in the windscreen prevents the projection of double images.

Therefore if the special windscreen needs to be replaced, it is strongly recommended that this be carried out by a Service Partner of the manufacturer or another qualified Service Partner or a specialist workshop.

Lights

Vehicle equipment

This chapter describes equipment, systems and functions which are offered or will be offered on a model-specific basis, even if they are not included in the vehicle in question.

For further information:





Vehicle equipment, see page 7.

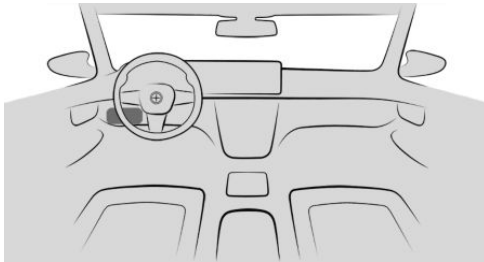

Lights and lighting

Overview



Buttons in the vehicle



Icon	Function
	Rear fog light.
	Lights off. Daytime driving lights.
	Side lights.
	Automatic driving lights control. Adaptive lighting functions.
	Low-beam headlight.

Icon	Function
	Instrument lighting.
	Parking light, right.
	Parking light, left.

Buttons on the vehicle key

Icon	Function
	Interior lighting. Parts of the exterior lights.
	Home lights.

Automatic driving lights control

Principle

Depending on ambient brightness, the system switches the low-beam headlight on or off automatically, for example in a tunnel, at twilight and in rain or snow.

General

The headlights may also come on when the sun is low against a blue sky.

If the low-beam headlights are switched on manually, the automatic driving lights control is deactivated.

Activating the automatic driving lights control

AUTO

Press the button on the light switch element.

The LED in the button illuminates.



The indicator light in the instrument cluster is illuminated when the low-beam headlight is switched on.

System limits

The automatic driving lights control is no substitute for using your own judgement to assess the light conditions.

The sensors are unable to recognise fog or hazy weather, for example. In such situations, switch on the lights manually.

Side lights, low-beam headlights and parking lights

General

If the driver's door is opened when drive-ready state is switched off, the exterior lights are switched off automatically after a given time.

Side lights

General

The side lights can only be switched on in the low speed range.

Switching on the side lights



Press the button on the light switch element.



The indicator light in the instrument cluster is illuminated.

The vehicle is illuminated all round.

Do not leave the side lights on for extended periods of time, as this could drain the vehicle battery and it may no longer be possible to switch on drive-ready state.

Switching off the side lights

The side lights can be switched off as follows:

OFF

▶ Press the button on the light switch element.

▶ Switch on drive-ready state.

After switching on drive-ready state, the automatic driving lights control is activated.

Low-beam headlight

Switching on the low-beam headlight



Press the button on the light switch element.

The low-beam headlight illuminates if drive-ready state is switched on.



The indicator light in the instrument cluster is illuminated.

To switch on the low-beam headlight as soon as the standby state is switched on, press the button again.

Switching off the low-beam headlight



Depending on the national-market version, the low-beam headlight may be switched off in the low speed range:

OFF

▶ Press the button on the light switch element.

Parking light

When parking the vehicle, it is possible to switch on a parking light on one side.

Button	Function
	Parking light, right on.
	Parking light, left on.

To switch off parking light:

 Press the button on the light switch element or switch on drive-ready state.

Welcome light

Principle

The exterior lights are turned on automatically for a limited period of time when approaching or unlocking the vehicle.

General

Depending on the equipment, the exterior lights of the vehicle can be individually adjusted.

Activating/deactivating welcome light

1. "MENU"
2. "Vehicle apps"
3. "Exterior lighting"
4. If necessary, "Additional settings"
5. Depending on the equipment, select the desired setting:
 - ▷ "Welcome and goodbye"

When unlocking the vehicle, individual lighting functions are turned on.

Turning on the welcome light

- ▷ Automatically on approach.
- ▷ During unlocking.

- ▷  With the vehicle locked, press the button on the vehicle key.

Depending on the settings, the interior lighting and parts of the exterior lighting will be turned on.

The function is not available for the first 10 seconds after locking.

Welcome Light Carpet

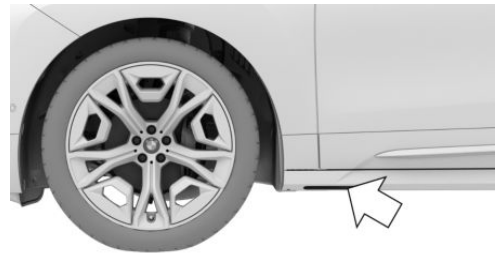

The light source is located in the position indicated.

Keep the light source clean and unobstructed.

Home lights

Principle

The exterior lights can be switched on for a certain period of time to illuminate the surroundings after exiting the vehicle.

Switching on the home lights

- ▷ After switching off drive-ready state, press the turn indicator lever forwards briefly.

- ▷  Press and hold the button on the vehicle key for approximately 1 second.

Activate the home lights function for the button of the vehicle key:

1. "MENU"
2. "Vehicle apps"
3. "Doors and windows"
4. "Vehicle key"
5. Select the desired setting.

Setting the duration

1. "MENU"
2. "Vehicle apps"
3. "Exterior lighting"
4. If necessary, "Additional settings"
5. "Home lights"
6. Select the desired setting.

Daytime running lights

General

The daytime running lights illuminate when drive-ready state is switched on.



The indicator light in the instrument cluster is illuminated when the rear daytime running lights are switched on.

Activating/deactivating daytime driving lights

In some countries, daytime driving lights are compulsory, in which case the daytime driving lights cannot be deactivated.

1. "MENU"
2. "Vehicle apps"
3. "Exterior lighting"
4. If necessary, "Additional settings"
5. Depending on national-market version: "Daytime driving lights" or "Rear daytime driving lights"

Dynamic ECO lighting function

General

The brightness of the low-beam headlight is reduced, depending on the speed and distance from the vehicle in front.

Activating the dynamic ECO light function

1.  If necessary, press the button on the light switch element to activate driving lights automatic.
The LED in the button illuminates.
2. Activate ECO PRO drive mode.
ECO PRO, see page 145.

Adaptive lighting functions

Principle

Adaptive lighting functions makes it possible to illuminate the road responsively.

General

The adaptive lighting functions consist of one system or multiple systems, depending on the equipment:

- ▶ Adaptive Headlights.
- ▶ Variable light distribution.
- ▶ Cornering light.
- ▶ Roundabout light.

Activating the adaptive light functions

1.  Press the button on the light switch element.

The LED in the button illuminates.

The adaptive lighting functions are active when drive-ready state is switched on.

Adaptive Headlights

General

The headlight beams follow the road ahead in response to the steering wheel angle and other parameters.

To prevent dazzling oncoming vehicles, the Adaptive Headlights do not swivel to the opposite side of the road when the vehicle is at standstill.

Depending on the equipment: if the headlights are converted, the availability of the Adaptive Headlights may be limited.

For further information:

Left-hand/right-hand traffic, see page 184.

Anticipatory Adaptive Headlights

The beams are adapted to the direction of travel ahead even before entering or leaving a bend.

S-bend lights

The beams are kept as straight as possible when driving around S-bends.

Hairpin lights

The cornering light is also switched on before entering hairpin bends.

Variable light distribution

Principle

The variable light distribution enables better illumination of the road.

General

The light distribution is adjusted automatically depending on speed and navigation data, if necessary.

Urban lights

The light beam from the low-beam headlight is extended at the sides.

Motorway beam pattern

The range of the low-beam headlight is increased.

Cornering light

Principle

When turning off or on tight bends, for example hairpin bends, up to a certain speed, a cornering light is added to illuminate the inside area of the bend.

General

The cornering light is switched on automatically depending on the steering wheel angle or, where applicable, activation of the turn indicators.

When reversing, the cornering light is activated automatically as appropriate, irrespective of the steering wheel angle.

Roundabout light

Shortly before driving onto a roundabout, the cornering light is activated on both sides. The edge of the road is illuminated more effectively. Shortly before leaving a roundabout, the cornering light is switched off again on both sides.

Adaptive headlight range control

Adaptive headlight range control compensates for acceleration and braking manoeuvres and vehicle load conditions to prevent oncoming vehicles from being dazzled.

High-beam Assistant

Principle

High-beam Assistant detects other road users in good time and activates or deactivates the high beam according to traffic situation.

General

High beam assistant ensures that the high-beam headlights are switched on when the traffic situation allows. The system does not switch on the high-beam headlights at low speeds.

The system responds to the lights from oncoming traffic and traffic driving ahead of you, and to ambient lighting, for example in built-up areas.

The high-beam headlights can be switched on and off manually at any time.

If Selective Beam is installed, the high-beam headlights are not switched off for oncoming vehicles or vehicles driving ahead of you. Instead, the system masks only those areas of the beam which would otherwise dazzle oncoming traffic or traffic driving ahead. In this case, the blue indicator lamp continues to illuminate.

Depending on the equipment: if the headlights have been converted, High-beam Assistant may only function to a limited extent.

For further information:

Left-hand/right-hand traffic, see page 184.

Operating requirements

- ▷ Automatic driving lights control is activated.
- ▷ Low-beam headlight is switched on.

Activating High-beam Assistant

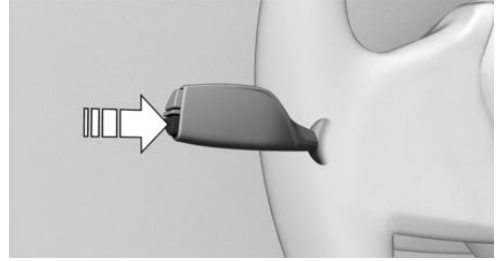

Press the button on the turn indicator lever.



The indicator light in the instrument cluster is illuminated when the low-beam headlight is switched on.

The system will switch automatically between low-beam headlight and high-beam headlight.



The blue indicator light in the instrument cluster illuminates if the high-beam headlight is switched on by the system.

If a journey is interrupted with High-beam Assistant activated: when the journey is resumed, High-beam Assistant remains activated.

The High-beam Assistant is deactivated by switching the high beams on and off manually.

To reactivate High-beam Assistant, press the button on the turn indicator lever.

Deactivating High-beam Assistant

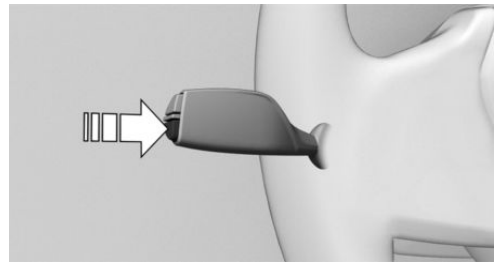

Press the button on the turn indicator lever.

System limits

High beam assistant cannot replace the driver's own judgement as to when to use the high-beam headlights. Therefore activate the dipped headlights manually if the situation requires it.

In the following situations, the system will not operate or its operation will be impaired and your intervention may be required:

- ▶ In extremely adverse weather conditions such as fog or heavy precipitation.
- ▶ When detecting poorly lit road users such as pedestrians, cyclists, horse riders or carriages and when trains or ships are close to the road, or when animals are crossing the road.
- ▶ On tight bends, on steep brows or hollows of hills, when there is crossing traffic or if the view of oncoming vehicles on a motorway is partly obstructed.
- ▶ In poorly lit towns or where there are highly reflective signs.
- ▶ If the area of windscreen in front of the interior mirror is covered with condensation, dirt, stickers, labels, etc.

Laser high-beam headlight

Principle

The headlight range of the high-beam headlight is increased and provides better illumination of the road.

General

The high-beam laser light is integrated into the headlight and is emitted there.

When the high-beam headlight is switched on, the laser high-beam headlight is switched on automatically in addition to LED high-beam headlight from a speed of approximately 60 km/h, 37 mph.

Depending on the national-market version, additional information may be found on the laser sign on the headlight.

Safety notes

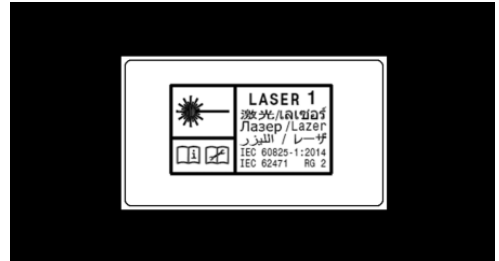

Laser class 1.

The sign is located in or on the headlight and is visible from the outside or when the bonnet is open.

Fog lights

Rear fog light

Operating requirements

The low-beam headlight must be switched on before the rear fog light can be activated.

Switching the rear fog light on/off



Press the button.



The yellow indicator lamp in the instrument cluster illuminates when the rear fog light is switched on.

If automatic driving lights control has been activated, the low-beam headlights switch on automatically when the rear fog light is switched on.

Bad weather light

Principle

The bad weather light provides optimised illumination of the road when visibility conditions are poor, for example in fog or rain. The light distribu-

tion from the low-beam headlight is adapted to the visibility conditions.

Activating/deactivating the bad weather light

The bad weather light is activated when the automatic driving light system or the rear fog light is switched on.

Left-hand/right-hand traffic

General

When driving in countries where vehicles drive on the opposite side of the road to your vehicle's country of registration, you will need to prevent your headlights from dazzling oncoming vehicles.

Converting the headlights

1. "MENU"
2. "Vehicle apps"
3. "Exterior lighting"
4. If necessary, "Additional settings"
5. "Right/left-hand traffic"
6. Select the desired setting.

Depending on the national-market version, the parking brake must be applied.

System limits

High-beam Assistant may only function to a restricted extent.

The availability of the adaptive lighting functions might be restricted.

Instrument lighting

Operating requirements

The brightness can only be adjusted when the side lights or low-beam headlight are switched on.

Adjusting the brightness



The brightness can be adjusted using the knurled wheel.

Interior lighting

General

Depending on the equipment, the interior lights, the footwell lights, door entry lighting, ambient lighting and loudspeaker lighting are controlled automatically.

Overview

Buttons in the vehicle

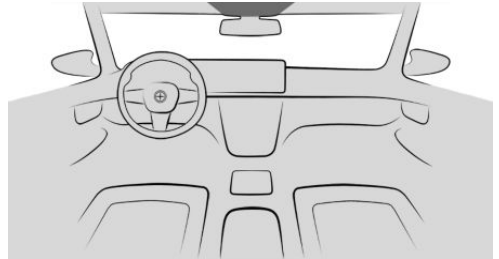

Reading lights



Interior lights



Press the button.

Turning interior lights on/off

To switch off permanently: press and hold the button for approximately 3 seconds.

The interior lights in the rear can be switched on and off independently. The button is located on the headliner in the rear.

Turning reading lights on/off



Press the button.

Depending on the equipment, there are reading lights located at the front and in the rear beside the interior lights.

Ambient lighting

General

Depending on the equipment, the lighting for some of the interior lights can be adjusted.

Activating/deactivating ambient light

1. "MENU"
2. "Vehicle apps"
3. "Interior lighting"
4. If necessary, "Ambience"
5. "Ambient lighting"

Turning ambient lighting on/off

The ambient lighting is switched on when the vehicle is unlocked and switched off when the vehicle is locked.

If the ambient lighting was deactivated using iDrive, it is not switched on when the vehicle is unlocked.

Selecting the colour

1. "MENU"
2. "Vehicle apps"
3. "Interior lighting"
4. If necessary, "Ambience"
5. "Colour"
6. Select the desired setting.

Adjusting the brightness

1. "MENU"
2. "Vehicle apps"
3. "Interior lighting"
4. If necessary, "Ambience"
5. "Brightness"
6. Select the desired setting.

Dynamic light

Individual actions, for example incoming calls or open doors, are indicated by light effects.

1. "MENU"
2. "Vehicle apps"
3. "Interior lighting"
4. If necessary, "Ambience"
5. "Dynamic light"
6. Select the desired setting.

Reduced for journey at night

Some lights of the interior lighting are reduced when the vehicle is driven in the dark.

1. "MENU"
2. "Vehicle apps"
3. "Interior lighting"
4. If necessary, "Ambience"
5. "Reduced for night driving"

Safety

Vehicle equipment

This chapter describes equipment, systems and functions which are offered or will be offered on

a model-specific basis, even if they are not included in the vehicle in question.

For further information:

Vehicle equipment, see page 7.

Airbags

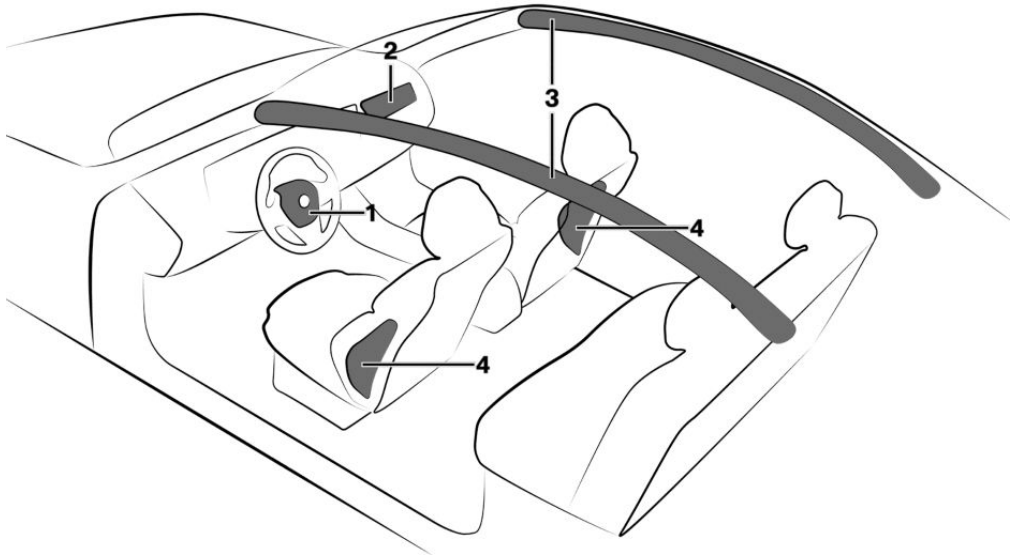

1 Front airbag, driver

2 Front airbag, front passenger

3 Head airbag

4 Side airbag

Front airbags

Front airbags protect the driver and front passenger in the event of a head-on collision where the protection of the seat belts alone would no longer be sufficient.

Head airbag

The head airbag protects the head in the event of a side-on crash.

Side airbag

In a side-on crash, the side airbag protects the side of the body in the chest and pelvic area.

Protective effect

General

Airbags are not activated in every collision situation, for example, in minor accidents.

Information for optimum airbag protective effect

WARNING

If the seat position is incorrect or the deployment area of the airbag is restricted, the airbag system cannot provide the intended level of protection or may cause additional injuries when it deploys. There is a risk of injury or even death. Observe the following to achieve optimum protective function.

- ▶ Keep a distance from the airbags.
- ▶ Always grip the steering wheel at the steering wheel rim. Place your hands in the 3 o'clock and 9 o'clock positions to minimise the risk of injury to hands or arms when the airbag deploys.
- ▶ Adjust the seat and steering wheel so the driver can reach over the steering wheel diagonally. Select the settings so that, when reaching over, the shoulders stay in contact with the backrest and the upper body stays as far away from the steering wheel as possible.
- ▶ Make sure that the front passenger is sitting correctly, i.e. with their feet and legs in the footwell, not resting on the dashboard.
- ▶ Make sure that vehicle occupants keep their head away from the side airbag.
- ▶ Do not place any other persons, pets or objects between the airbags and occupants.
- ▶ Keep the dashboard and windscreen area on the passenger's side clear, for example do not attach adhesive foil or covers and do not fit brackets for navigation device or mobile phone, for example.
- ▶ Do not glue the airbag covers and do not cover or modify them in any way.
- ▶ Do not use the front airbag cover on the passenger's side as a tray.
- ▶ Do not attach slip covers, seat cushions or other objects to the front seats that are not

specifically suited for seats with integrated airbag versions.

- ▶ Do not hang items of clothing, for example coats or jackets, over the backrests.
- ▶ Do not modify individual components of the system or its wiring. This also applies to the covers of the steering wheel, the dashboard and seats.
- ▶ Do not dismantle the airbag system.

Even if all this information is observed, injuries resulting from contact with the airbag cannot be entirely ruled out in every situation.

The noise caused by the deployment of an airbag may lead to temporary hearing loss in vehicle occupants sensitive to noise.

Operational readiness of the airbag system

Safety notes

WARNING

Individual components of the airbag system may be hot after airbag deployment. There is a danger of injury. Do not touch individual components.

WARNING

Work carried out incorrectly can cause the airbag system to fail, malfunction or deploy accidentally. If there is a malfunction, the airbag system might not deploy as intended in an accident, even if the impact is of the appropriate severity. There is a risk of injury or even death. Have the airbag system tested, repaired or removed and disposed of by a Service Partner of the manufacturer or another qualified Service Partner or a specialist workshop.

Display in the instrument cluster



When drive-ready state is switched on, the warning light in the instrument cluster illuminates briefly to indicate that the entire airbag system and the seat belt tensioners are operational.

Malfunction



- ▶ The warning light does not illuminate after drive-ready state is switched on.
- ▶ The warning light is permanently illuminated.

Have the system checked.

Setting the front seat positions

General

In order to maintain the accuracy of the seat position permanently, calibrate the front seats as soon as a corresponding message is displayed on the control display.

Calibrating the front seats

WARNING

There is a risk of entrapment when the seats are moved. There is a risk of injury or material damage. Before making any adjustment, make sure that the area of movement of the seat is clear.

A corresponding message is displayed on the control display.

1. Press switch and move seat forwards until it stops.
2. Press switch forwards again. Seat moves a bit further forwards.
3. Readjust the desired seat position.

The calibration is concluded when the message on the control display disappears.

If the message is still displayed, repeat the calibration.

If the message still does not go out after repeated calibration, have the system checked as soon as possible.

Key switch for front passenger airbags

Principle

When a child restraint system is used on the front passenger seat, the front and side airbags on the passenger's side can be deactivated using the key switch for front passenger airbags.

General

The front and side airbags for the front passenger can be deactivated and reactivated using the integrated key from the vehicle key.

Overview

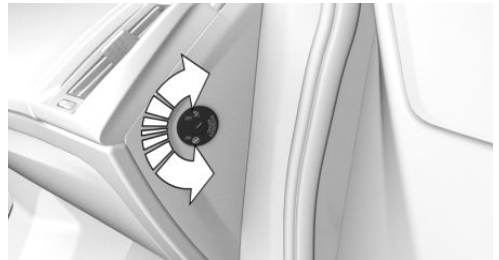

The key switch for front passenger airbags is located on the outside of the dashboard.

Deactivating the front passenger airbags



1. Insert the key and press inwards where necessary.
2. With the key pressed inwards, turn the switch to the OFF position as far as it will go. Once the stop position has been reached, remove the key.
3. Make sure that the key switch is in the end position so that the airbags are deactivated.

The front passenger airbags are deactivated. The driver's airbags remain active.

If a child restraint system is removed from the front passenger seat, reactivate the front passenger airbags so that they can deploy as intended in the event of an accident.

The airbag status is shown by the indicator light on the headliner.

the stop position has been reached, remove the key.



3. Make sure that the key switch is in the end position so that the airbags are activated.

The front passenger airbags are reactivated and can deploy correctly when required to do so.

Indicator light for front passenger airbags

The indicator light for the front passenger airbags in the headliner shows the operating status of the front passenger airbags.

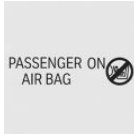
After switching on drive-ready state, the light illuminates briefly and then shows whether the airbags are activated or deactivated.

Display	Function
	If the front passenger airbags are activated, the indicator light illuminates for a short period and then extinguishes.
	When the front passenger airbags are deactivated, the indicator light remains illuminated.

Activating the front passenger airbags



1. Insert the key and press inwards where necessary.
2. With the key pressed inwards, turn the switch to the ON position as far as it will go. Once

Active pedestrian protection

Principle

The active pedestrian protection raises the bonnet if the front of the vehicle collides with a pedestrian.

General

When triggered, the pedestrian protection system creates deformation space underneath the front flap in readiness for the subsequent head impact. Sensors underneath the bumper are used for detection.

Safety notes

WARNING

The system may trigger inadvertently if contact is made with individual components of the hinges and front flap locks. There is a risk of injury or material damage. Do not touch individual components of the hinges and front flap locks.

WARNING

Modifications to the pedestrian protection system can lead to a failure, a malfunction or accidental triggering of the pedestrian protection system. There is a risk of injury or even death. Do not modify the pedestrian protection system, its individual components or its wiring. Do not dismantle the system.

WARNING

Work carried out incorrectly can lead to a failure, malfunction or accidental triggering of the system. If there is a malfunction, the system might not trigger as intended in an accident, even if the impact is of the appropriate severity. There is a risk of injury or even death. Have the system tested, repaired or removed and disposed of by a Service Partner of the manufacturer or another qualified Service Partner or a specialist workshop.

WARNING

If the system has been deployed or is damaged, its functionality will be limited or it may no longer work at all. There is a risk of injury or even death.

If the system has been triggered or is damaged, have it checked and renewed at a Service Partner of the manufacturer or another qualified Service Partner or a specialist workshop.

NOTE

Opening the front flap when the pedestrian protection system has triggered may damage the front flap or the pedestrian protection system. There is a risk of material damage. Do not open the front flap after the Check Control message is displayed. Have checks performed by a Service Partner of the manufacturer or another qualified Service Partner or a specialist workshop.

System limits

The active pedestrian protection system is only triggered at speeds between approximately 30 km/h, 18 mph and 55 km/h, 34 mph.

For safety reasons, the system may also trigger in rare instances where impact with a pedestrian cannot be excluded beyond all doubt, for example in the following situations:

- ▶ Collision with objects such as a skip or a boundary post.
- ▶ Collision with animals.
- ▶ Stone impact.
- ▶ Driving into a snow drift.

Malfuction



A Check Control message is shown.

The system has been triggered or is faulty.

Immediately drive at moderate speed to a Service Partner of the manufacturer or another qualified Service Partner or a specialist workshop to have the system checked and repaired.

Collision warning systems

General

Depending on the equipment, the vehicle has different systems that can help prevent an imminent collision.

- ▶ Front-collision warning, see page 192.
- ▶ Lane Departure Warning, see page 199.
- ▶ Lane Change Warning, see page 202.
- ▶ Side collision warning, see page 205.
- ▶ Road Priority Warning, see page 207.
- ▶ Wrong-way Warning, see page 209.
- ▶ Rear Collision Prevention, see page 206.
- ▶ Emergency Stop Assistant, see page 210.

Safety notes

WARNING

The system does not relieve you of your personal responsibility to assess the visibility conditions and traffic situation correctly. There is a risk of accident. Adapt your driving style to the traffic conditions. Observe the traffic situation and intervene actively if the situation warrants it.

WARNING

Displays and warnings do not relieve you of your personal responsibility. System limitations can mean that warnings or system responses are not issued or are issued too late, incorrectly or without justification. There is a risk of accident. Adapt your driving style to the traffic conditions. Observe the traffic situation and intervene actively if the situation warrants it.

Turning on/turning off collision warning systems

Depending on the national-market version, some of the systems are automatically active after every driving off.

The following functions are adjustable.

1. "MENU"
2. "Vehicle apps"
3. "Driving settings"
4. "Driver assistance"
5. "Safety and warnings"
6. Select the desired settings.

Resetting settings

The settings of the collision warning systems can be reset to the default settings for vehicle delivery.

1. "MENU"
2. "Vehicle apps"
3. "Driving settings"
4. "Driver assistance"
5. "Safety and warnings"
6. "Reset to recommended settings"

System limits

Safety note

WARNING

The system may not respond at all, or may respond too late, incorrectly or without justification due to system limitations. There is a risk of accident or material damage. Observe the information on the system limits and intervene actively if necessary.

Detection capability

The detection capability of the system is limited.

Only objects within the detection range of the installed sensors and that are detected by the system are taken into account.

Depending on the equipment, the area is monitored by cameras or radar sensors.

For this reason, the system may fail to respond or only respond after a delay.

System limits of the sensors

For further information:

Sensors in the vehicle, see page 47.

Front-collision warning

Principle

The front-collision warning can help prevent accidents. If an accident cannot be avoided, the system may help reduce the severity of the accident.

The system can issue a warning of a possible risk of collision and may activate the brakes independently.

General

Depending on the equipment version, the front-collision warning includes the following functions:

- ▶ Collision Warning with braking function, see page 195.
- ▶ Pedestrian Warning with city braking function, see page 196.
- ▶ Crossroads Warning with city braking function, see page 197.
- ▶ Evasion Assistant, see page 198.

Speed range

The system issues a warning of a possible risk of collision at speeds above approx. 5 km/h/3 mph.

The system is temporarily disabled at speeds over approx. 250 km/h, 155 mph.

Some functions are deactivated earlier.

As soon as the speed drops below these values again, the system will respond again according to its settings.

Safety notes

WARNING

The system does not relieve you of your personal responsibility to assess the visibility conditions and traffic situation correctly. There is a risk of accident. Adapt your driving style to the traffic conditions. Observe the traffic situation and intervene actively if the situation warrants it.

WARNING

Displays and warnings do not relieve you of your personal responsibility. System limitations can mean that warnings or system responses are not issued or are issued too late, incorrectly or without justification. There is a risk of accident. Adapt your driving style to the traffic conditions. Observe the traffic situation and intervene actively if the situation warrants it.

WARNING

Due to system limits, individual functions can malfunction during tow-starting/tow-away when the front-collision warning is activated. There is a risk of accident. Turn the front-collision warning off prior to tow-starting/towing.

Sensors

Depending on the equipment, the system is controlled by the following sensors:

- ▶ Camera behind the windscreen.
- ▶ Front radar sensor.
- ▶ Side radar sensors, front.

Turning the front-collision warning on/off

Turning on the system automatically

Depending on the national-market version, the system is automatically active after every driving off.

Turning the system on manually

The system is activated when the warning time is set.

For further information:

Setting the warning time, see page 193.

Turning the system off manually

Depending on the national-market version, the adjustment can only be made at a vehicle standstill or in the very low speed range.

1. "MENU"
2. "Vehicle apps"
3. "Driving settings"
4. "Driver assistance"
5. "Safety and warnings"
6. "Front collision warning"
7. "Off"

Setting the warning time

1. "MENU"
2. "Vehicle apps"
3. "Driving settings"
4. "Driver assistance"
5. "Safety and warnings"
6. "Front collision warning"
7. Select the desired setting.
 - ▷ "Early"
 - ▷ "Medium"
 - ▷ "Late": only acute warnings are displayed.







The higher the sensitivity of the warning time settings the more warnings are displayed. As a

result, there may also be an increased number of premature or unjustified warnings and responses.

The system checks for visual impairments. Depending on equipment, the Driver Attention Camera in the instrument cluster monitors the driver's gaze behaviour. Visibility conditions and field of vision also affect the timing of the warnings.

Display in the instrument cluster

Depending on the equipment, the following icons are displayed in the instrument cluster and Head-up display:

Icon	Meaning
	Depending on the national-market version: System is restricted or has failed.
	Depending on the national-market version: System is deactivated.
	Risk of collision, for example, with a pedestrian.
	Risk of collision, for example, with a vehicle driving in front.
	Risk of collision, for example, with a crossing vehicle.
	General risk of collision.

The image of the respective icon may vary, because the system may detect multiple objects.

Warning function

The front-collision warning warns on different warning levels, depending on the respective hazardous situation.

In the event of a system warning, the driver must intervene immediately and in accordance with the situation.

- ▷ A red icon illuminates:
 - A hazardous situation has been detected. Increased awareness is required.
- ▷ A red icon flashes:
 - There is a risk of collision. Intervene yourself immediately.
- ▷ A warning signal sounds:
 - There is a risk of collision. Intervene yourself immediately.
- ▷ Automatic brake intervention:
 - Depending on the equipment and situation in case of an imminent danger of collision, the system can also intervene with an automatic brake intervention and automatically decelerate the vehicle, if necessary, to a complete stop.

When the brake is operated during a warning, the maximum necessary brake force is applied. This requires the brake pedal to be pressed sufficiently quickly and firmly.

Automatic brake intervention

In case of a risk of collision, the system can assist with an automatic brake intervention, if necessary.

At low speeds, the vehicle can be braked to a stop.

A brake intervention can be cancelled by stepping on the accelerator pedal, releasing the brake pedal or with an active steering movement.

Depending on the equipment and situation, the brake intervention can occur at speeds of up to approx. 250 km/h/155 mph.

At speeds above approx. 210 km/h/130 mph, only a brief brake intervention will occur.

System limits

Safety note

WARNING

The system may not respond at all, or may respond too late, incorrectly or without justification due to system limitations. There is a risk of accident or material damage. Observe the information on the system limits and intervene actively if necessary.

Detection capability

The detection capability of the system is limited. Only objects within the detection range of the installed sensors and that are detected by the system are taken into account.

Depending on the equipment, the area is monitored by cameras or radar sensors.

For this reason, the system may fail to respond or only respond after a delay.

System limits of the sensors

For further information:

Sensors in the vehicle, see page 47.

Functional limitations

The system may have restricted functionality in situations such as the following:

- ▷ On sharp bends.
- ▷ With restriction of the driving stability control systems.
- ▷ Up to 10 seconds after switching on drive-ready state using the Start/Stop button

Malfunction

In the event of a system fault, a Check Control message or indicator/warning lights will generally be displayed.

A system fault can be triggered by the failure of individual components, for example:

- ▶ Sensors, for example camera.
- ▶ Control units, for instance for the Dynamic Stability Control.

Collision Warning with braking function

Principle

The Collision Warning with braking function warns of a possible risk of collision and may brake independently.

If an accident cannot be avoided, the system helps to reduce the collision speed.

General

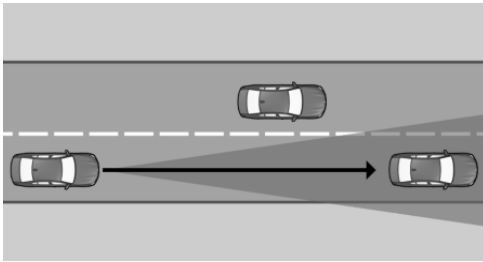

Sensors record the traffic situation.

The system issues a warning of a possible risk of collision with vehicles at speeds above approx. 5 km/h/3 mph. The timing of these warnings may vary depending on the current driving situation.



When deliberately moving closer to a vehicle, the Collision Warning and brake intervention are activated later to avoid unwarranted system responses.

Safety notes

Follow the Safety Information in Chapter “Front-collision warning”.

Display in the instrument cluster

A warning symbol is displayed when a collision with a detected vehicle is imminent.

Icon	Meaning
	Collision Warning with a detected vehicle.
	General risk of collision.

Warning function

The warning prompts the driver to intervene personally.

For further information:

Front-collision warning, see page 192.

System limits

General

Follow the limits of the system in the chapter “Front-collision warning”.

Detection range

The following situations may not be detected, or only detected with a delay, for instance:

- ▶ Slow-moving vehicle when approaching it at high speed.
- ▶ Vehicles suddenly cutting in or decelerating heavily.
- ▶ Vehicles with an unusual rear appearance.
- ▶ Two-wheeled vehicles ahead.

Upper speed limit

The system is temporarily disabled at speeds over approx. 250 km/h, 155 mph. Once the speed drops back below this threshold, the system becomes responsive again according to its settings.

Pedestrian Warning with city braking function

Principle

In the urban speed range, the Pedestrian Warning with city braking function warns of a possible risk of collision with pedestrians and bicycle riders, and may brake independently.

If an accident cannot be avoided, the system helps to reduce the collision speed.

General

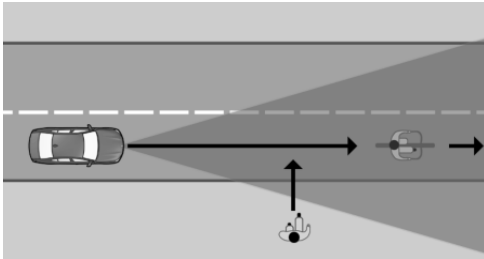

Sensors record the traffic situation.

Persons within the detection range who are detected by the system are taken into account.

The system issues a warning of a possible risk of collision with pedestrians at speeds above approx. 5 km/h/3 mph.

Safety notes

Follow the Safety Information in Chapter “Front-collision warning”.

Display in the instrument cluster

A warning symbol is displayed when a collision with a detected pedestrian is imminent.

Icon	Meaning
	General risk of collision.
	Risk of collision with a pedestrian.



Risk of collision with a pedestrian.



General risk of collision.

Warning function

The warning prompts the driver to intervene personally.

For further information:

Front-collision warning, see page 192.

System limits

General

Follow the limits of the system in the chapter “Front-collision warning”.

Detection range

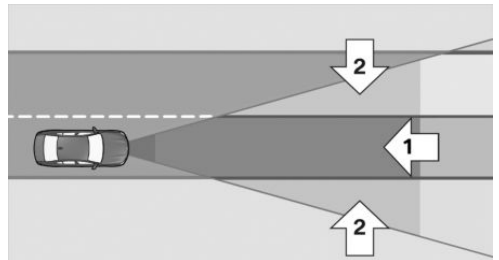

The detection range in front of the vehicle consists of two parts:

- ▶ Central zone, arrow 1, directly in front of the vehicle.
- ▶ Extended zone, arrows 2, to the right and left of the central area.

There is a risk of collision if persons are in the central zone. A warning is only given if persons in the extended zone are moving towards the central zone.

For example the following might not be detected:

- ▶ Partially covered pedestrians or bikes.
- ▶ Pedestrians that are not detected as such because of their contour or posture.
- ▶ Pedestrians with insufficient height.

Upper speed limit

Depending on the equipment, the system reacts to pedestrians when your own speed is up to 80 km/h, approx. 50 mph.

Crossroads Warning with city braking function

Principle

In the urban speed range, the Crossroads Warning with city braking function can warn of possible risk of collision with crossing traffic at road junctions and crossroads, and may brake independently.

If an accident cannot be avoided, the system helps to reduce the collision speed.

General

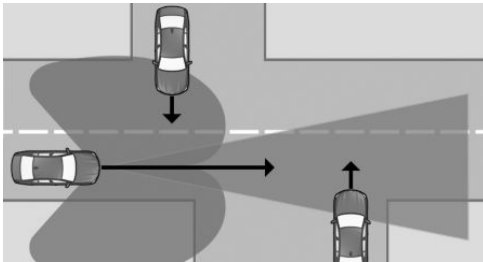

Sensors record the traffic situation.

Vehicles that cross the vehicle's direction of travel can be detected by the system as soon as these vehicles enter the detection range of the system.

A warning is given at road junctions and crossroads if there is a risk of collision with crossing traffic.

From speeds of approximately 10 km/h, approx. 6 mph, the system provides a warning of possible risk of collision with vehicles.

The timing of these warnings may vary depending on the current driving situation.

Safety notes

Follow the Safety Information in Chapter "Front-collision warning".

Display in the instrument cluster

A warning symbol is displayed when a collision with a detected vehicle is imminent.

Icon	Meaning
	Risk of collision with crossing vehicle from right.
	Risk of collision with crossing vehicle from left.
	General risk of collision.

Warning function

The warning prompts the driver to intervene personally.

For further information:

Front-collision warning, see page 192.

System limits

General

Follow the limits of the system in the chapter "Front-collision warning".

Detection range

For example the following might not be detected:

- ▶ Crossing vehicles concealed by buildings, for example.
- ▶ Vehicles with an unusual side appearance.

- ▷ Vehicles in highly dynamic driving situations.
- ▷ Vehicles suddenly cutting in or decelerating heavily.
- ▷ Crossing two-wheeled vehicles.

Upper speed limit

The system responds to crossing vehicles when your own speed is below approx. 80 km/h, approx. 50 mph.

Evasion Assistant

Principle

The Evasion Assistant can support the driver in making evasive manoeuvres in certain situations, for example, when obstacles or persons suddenly appear.

General

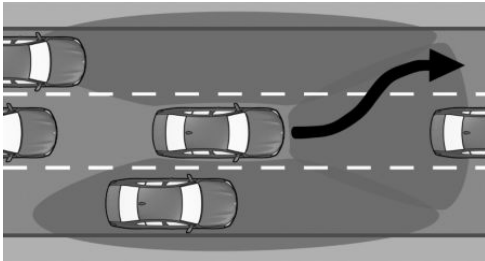

The system issues warnings and intervenes to provide support if there is a possibility to take an avoidance manoeuvre to the side.

Sensors monitor and detect the clearance in front of the vehicle. Depending on the equipment, the areas next to the vehicle are also monitored.

The system then utilises the detected free space to take the avoidance manoeuvre by steering the vehicle safely and precisely in the direction specified by the driver by means of supporting steering wheel movements.

Safety notes



Follow the Safety Information in Chapter “Front-collision warning”.

Operating requirements

- ▷ Front-collision warning is active.
- ▷ Sensors detect adequate space around the vehicle.

Display in the instrument cluster

A warning symbol is displayed when a collision with a detected vehicle or a detected pedestrian is imminent.

Icon	Meaning
	Warning when a vehicle is detected.
	Warning when a pedestrian is detected.
	Warning for unknown obstacles.

Warning function with evasion support

A warning is displayed when the vehicle is approaching another object at a high differential speed and there is an immediate risk of collision. Intervene in case of a warning.

The system provides support for the driver's avoidance manoeuvres if there is a risk of collision.

System limits

General

Follow the limits of the system in the chapter “Front-collision warning”.

Detection range

For example the following might not be detected:

- ▶ Slow-moving vehicle when approaching it at high speed.
- ▶ Vehicles suddenly cutting in or decelerating heavily.
- ▶ Vehicles with an unusual rear appearance.
- ▶ Two-wheeled vehicles ahead.
- ▶ Partially covered pedestrians or bikes.
- ▶ Pedestrians that are not detected as such because of their contour or posture.
- ▶ Pedestrians with insufficient height.

Lane Departure Warning

Principle

The Lane Departure Warning issues a warning if the vehicle leaves the road or its driving lane.

General

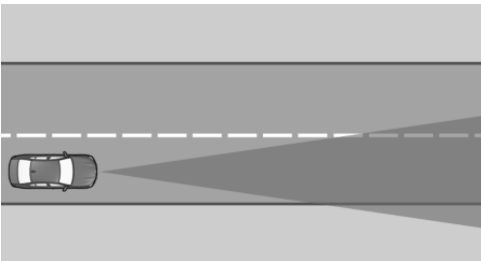

Sensors record the traffic situation.

The system issues a warning starting at a minimum speed. The minimum speed is country-specific and displayed on the control display.

Warnings are displayed in the instrument cluster. In addition, the steering wheel is vibrating. The strength of the steering wheel vibration can be adjusted.

The system does not issue a warning if the driver indicates in the corresponding direction before leaving the driving lane.

Safety notes

WARNING

The system does not relieve you of your personal responsibility to assess the layout of the road and the traffic situation. There is a risk of accident. Adapt your driving style to the traffic conditions. Observe the traffic situation and intervene actively if the situation warrants it. In the event of a warning, do not move the steering wheel unnecessarily abruptly.

WARNING

Displays and warnings do not relieve you of your personal responsibility. System limitations can mean that warnings or system responses are not issued or are issued too late, incorrectly or without justification. There is a risk of accident. Adapt your driving style to the traffic conditions. Observe the traffic situation and intervene actively if the situation warrants it.

Operating requirements

The lane marking must be detected by the camera in order for the Lane Departure Warning to be active.

Sensors

The system is controlled by the camera behind the windscreen.

Turning the Lane Departure Warning on/off

Turning on the system automatically

Depending on the national-market version, the system is automatically active after every driving off.

Turning the system on manually

The system is activated when the warning time is set.

For further information:

Setting the warning time, see page [200](#).

Turning the system off manually

1. "MENU"
2. "Vehicle apps"
3. "Driving settings"
4. "Driver assistance"
5. "Safety and warnings"
6. "Lane departure warning"
7. "Off"

Setting the Lane Departure Warning

Setting the warning time

1. "MENU"
2. "Vehicle apps"
3. "Driving settings"
4. "Driver assistance"
5. "Safety and warnings"
6. "Lane departure warning"
7. Select the desired setting.
 - ▷ "Early"
 - ▷ "Medium"
 - ▷ "Reduced"

Some warnings are suppressed depending on the situation, for instance, when purposely driving over driving lane lines in bends or with dynamic overtaking without turn indicator.

Adjusting the strength of the steering wheel vibration

1. "MENU"
2. "Vehicle apps"
3. "Driving settings"



4. "Driver assistance"
5. "Feedback via steering wheel"
6. "Vibration intensity"
7. Select the desired setting.

The setting is applied to all collision warning systems.

Depending on the national-market version: turn steering intervention on/off

1. "MENU"
2. "Vehicle apps"
3. "Driving settings"
4. "Driver assistance"
5. "Safety and warnings"
6. "Lane departure warning"
7. "Steering intervention"

Display in the instrument cluster

Icon	Meaning
	Depending on the national-market version: Icon illuminates green: a lane boundary was detected on at least one side of the vehicle and warnings can be issued. The system can perform steering interventions.
	Icon flashes green: the vehicle is going to drive across the lane boundary.
	Depending on the national-market version: Icon is illuminated yellow: the system is restricted, deactivated or has failed.

Warning function

When leaving the driving lane

If the vehicle leaves the driving lane and a lane marking is detected, the steering wheel vibrates depending on the steering wheel vibration setting.



In addition, the icon starts to flash.

If the turn indicator is switched on in the corresponding direction before changing lanes, no warning is issued.

Steering intervention

Depending on the national-market version: if a lane boundary is crossed in the speed range up to 210 km/h/130 mph, the system may respond with an active steering intervention in addition to the steering wheel vibration. The system thereby helps to keep the vehicle in driving lane. Steering intervention can be felt at the steering wheel, and can be overridden manually at any time.

For example, steering intervention is suppressed in the following situations:

- ▶ If the vehicle is accelerating rapidly or braking heavily.
- ▶ On indicating.
- ▶ If the hazard warning lights are switched on.
- ▶ In driving situations with high driving dynamics.
- ▶ The Dynamic Stability Control adjusts.
- ▶ Directly after a steering intervention by the vehicle systems.

Warning signal

Depending on the national-market version: in the event of multiple active steering interventions by the system within 3 minutes without the driver's intervention at the steering wheel during the steering intervention itself, an acoustic warning will sound. A short warning signal will sound at the second steering intervention. A longer warn-

ing signal sounds from the third steering intervention onwards.

A Check Control message is also displayed.

The warning signal and Check Control message advise to pay closer attention to the lane.

In trailer operation

If the trailer socket is occupied or the trailer mode is activated, for example during operation with trailer, no steering intervention takes place.

Cancellation of the warning

For example, the warning or an active steering intervention is cancelled in the following situations:

- ▶ Automatically after a few seconds.
- ▶ On returning to the correct lane.
- ▶ If the vehicle is accelerating rapidly or braking heavily.
- ▶ If the hazard warning lights are switched on.
- ▶ On indicating.
- ▶ The Dynamic Stability Control is controlling the vehicle or it is deactivated.
- ▶ Directly after a steering intervention by the vehicle systems.
- ▶ With manual steering intervention.
- ▶ Possibly when another driver assistance system is activated.
- ▶ Lane boundaries are not detected.
- ▶ When the system limits are reached.

System limits

General

Follow the limits of the system in the chapter "Collision warning systems".

Functional limitations

The system may have restricted functionality in situations such as the following:

- ▶ When there are missing, worn, poorly visible, merging/separating or ambiguous lane mark-

ings, for example, in areas where there are roadworks.

- ▷ With lane boundaries that are covered in snow, ice, dirt or water.
- ▷ On sharp bends or narrow roads.
- ▷ With lane boundaries that are not white.
- ▷ With lane boundaries that are covered by objects.
- ▷ If the vehicle is too close to the vehicle ahead.
- ▷ Up to 10 seconds after switching on drive-ready state using the Start/Stop button.
- ▷ The Dynamic Stability Control is deactivated.

A Check Control message may be displayed if functionality is restricted. Depending on the national-market version, a yellow icon is also illuminated.

Lane Change Warning

Principle

Lane Change Warning detects vehicles in the blind spot, or if vehicles are approaching from behind in the adjacent lane.

The light in the exterior mirror warns in different increments.

General

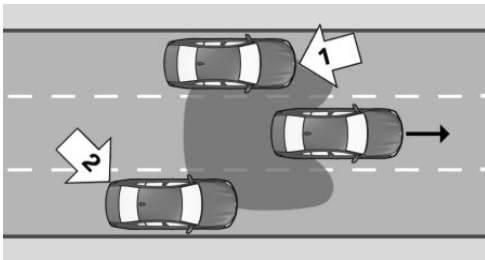

The system is operational after a minimum speed has been reached and uses radar sensors to monitor the area behind and adjacent to the vehicle.

The minimum speed is country-specific and displayed in the Lane Change Warning menu.

The system indicates when vehicles are in the blind spot, arrow 1, or are approaching from the rear in an adjacent lane, arrow 2.

The light in the exterior mirror illuminates at a dimmed level.

In the above situations, the system issues a warning before a lane change with the turn indicator activated.

The light in the exterior mirror flashes and the steering wheel vibrates.

When turning at a speed of up to approx. 20 km/h/12 mph, the steering wheel will not vibrate.

Safety notes

Follow the safety information in the Chapter "Collision warning systems".

Sensors

The system is controlled via the radar sensors at the side in the rear.

Turning the Lane Change Warning on/off

1. "MENU"
2. "Vehicle apps"
3. "Driving settings"
4. "Driver assistance"
5. "Safety and warnings"
6. "Lane change warning"
7. Select the desired setting.

Adjusting the Lane Change Warning

Setting the warning time

1. "MENU"
2. "Vehicle apps"
3. "Driving settings"

4. "Driver assistance"
5. "Safety and warnings"
6. "Lane change warning"
7. Select the desired setting.

Adjusting the strength of the steering wheel vibration



1. "MENU"
2. "Vehicle apps"
3. "Driving settings"
4. "Driver assistance"
5. "Feedback via steering wheel"
6. "Vibration intensity"
7. Select the desired setting.

The setting is applied to all collision warning systems.

Depending on the national-market version: turn steering intervention on/off

1. "MENU"
2. "Vehicle apps"
3. "Driving settings"
4. "Driver assistance"
5. "Safety and warnings"
6. "Lane change warning"
7. "Steering intervention"

Display in the instrument cluster

Icon	Meaning
	Depending on the national-market version: Icon is illuminated green: the system is turned on. Warnings and, if necessary, steering interventions can occur within the system limits.
	Depending on the national-market version: The icon is illuminated yellow and in some cases in combination with a Check Control message: the system is restricted or has failed.
	Depending on the national-market version: Icon is illuminated yellow: the system turned off.

Warning function

Light in the exterior mirror



The light in the exterior mirror warns of a possible collision.

Advance warning

The dimmed light in the exterior mirror indicates when vehicles are in the blind spot or are approaching from the rear.

Acute warning

In case of an acute warning, the steering wheel briefly vibrates and the light in the exterior mirror flashes brightly.

An acute warning occurs when the following conditions are met:

- ▶ Another vehicle is located in the critical area.
- ▶ Your own vehicle is approaching the other lane.
- ▶ Depending on the system setting when the turn indicator is turned on.

The warning is terminated when the other vehicle has left the critical area or the turn indicator has been switched off.

Steering intervention

Depending on the national-market version: if there is no response to the steering wheel vibrations and a lane boundary is crossed at speeds of up to 210 km/h, approx. 130 mph, the system responds, if necessary, with an active steering intervention. The steering intervention helps to return the vehicle to its driving lane. Steering intervention can be felt at the steering wheel, and can be overridden manually at any time.

The steering intervention is performed if a minimum speed has been reached. The minimum speed is displayed on the control display.

Flashing of light

A flashing of the light in exterior mirror during vehicle unlocking serves as system self-test.

System limits

General

Follow the limits of the system in the chapter "Collision warning systems".

Upper speed limit

The system is temporarily disabled at speeds over approx. 250 km/h, 155 mph.

The system becomes responsive again, according to settings, once vehicle speed drops back below approx. 250 km/h, 155 mph.

Warning displays

Depending on the selected setting for warnings, for example the warning time, it is possible that more or fewer warnings will be displayed. As a result, there may also be an increased number of premature warnings about critical situations.

Functional limitations

The system may have restricted functionality in situations such as the following:

- ▶ The speed of the approaching vehicle is much faster than your own speed.
- ▶ On sharp bends or narrow roads.
- ▶ The bumper is dirty, iced up or covered, for instance by stickers.

Depending on the national-market version: the steering intervention may be restricted, for example, in the following situations:

- ▶ When there are missing, worn, poorly visible, merging/separating or ambiguous lane markings, for example, in areas where there are roadworks.
- ▶ With lane boundaries that are covered in snow, ice, dirt or water.
- ▶ With lane boundaries that are not white.
- ▶ With lane boundaries that are covered by objects.
- ▶ If the vehicle is too close to the vehicle ahead.
- ▶ If the camera is impaired.
- ▶ Up to 10 seconds after switching on drive-ready state using the Start/Stop button.

A Check Control message may be displayed if functionality is restricted. Depending on the national-market version, a yellow icon is also illuminated.

The system is inactive when the trailer socket is occupied or when the trailer operation is activated, for example, when operating with a trailer or

bicycle carrier. A Check Control message is shown.

Side collision warning

Principle

The side-collision warning helps to avoid imminent side collisions.

General

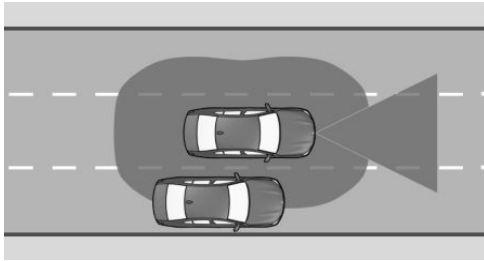

Radar sensors monitor the area adjacent to the vehicle from a minimum speed up to approximately , 210 km/h, approx. 130 mph.

The minimum speed is country-specific and displayed on the control display.

The camera behind the windscreen detects the position of the lane boundaries.

If another vehicle is detected adjacent to the vehicle – and there is a risk of a side collision – the system helps the driver to avoid a collision. For this purpose, the system issues a warning with a flashing LED in the exterior mirror, a Check Control message and a vibrating steering wheel. The system may perform an active steering intervention.

Safety notes

Follow the safety information in the Chapter “Collision warning systems”.

Operating requirements

The lane markings must be detected by the camera in order for the side collision warning with steering intervention to be active.

Sensors

The system is controlled using the following sensors:

- ▷ Camera behind the windscreen.
- ▷ Side radar sensors, front.
- ▷ Side radar sensors, rear.

Turning the side-collision warning on/off

1. "MENU"
2. "Vehicle apps"
3. "Driving settings"
4. "Driver assistance"
5. "Safety and warnings"
6. "Side collision warning"
7. Select the desired setting.

Adjusting the strength of the steering wheel vibration

1. "MENU"
2. "Vehicle apps"
3. "Driving settings"
4. "Driver assistance"
5. "Feedback via steering wheel"
6. "Vibration intensity"
7. Select the desired setting.

The setting is applied to all collision warning systems.

Warning function

Light in the exterior mirror



The light in the exterior mirror warns of a possible collision.

Acute warning

If there is a risk of collision, the light in the exterior mirror flashes and the steering wheel starts vibrating.

A Check Control message is displayed at the same time.

Steering intervention

Depending on the national-market version, if necessary, an active steering intervention takes place to prevent a collision and keep the vehicle in its own lane. Steering intervention can be felt at the steering wheel, and can be overridden manually at any time.

System limits

General

Follow the limits of the system in the chapter "Collision warning systems".

Functional limitations

The system may have restricted functionality in situations such as the following:

- ▶ The speed of the approaching vehicle is much faster than your own speed.
- ▶ On sharp bends or narrow roads.

- ▶ When there are missing, worn, poorly visible, merging/separating or ambiguous lane markings, for example, in areas where there are roadworks.
- ▶ With lane boundaries that are covered in snow, ice, dirt or water.
- ▶ With lane boundaries that are not white.
- ▶ With lane boundaries that are covered by objects.
- ▶ If the vehicle is too close to the vehicle ahead.
- ▶ Up to 10 seconds after switching on drive-ready state using the Start/Stop button.

A Check Control message is displayed in the event of restricted functionality.

The system is inactive when the trailer socket is occupied or when the trailer operation is activated, for example, when operating with a trailer or bicycle carrier. A Check Control message is shown.

Rear Collision Prevention

Principle

Depending on the equipment and the national-market version, the Rear Collision Prevention can respond to vehicles approaching from behind.

General

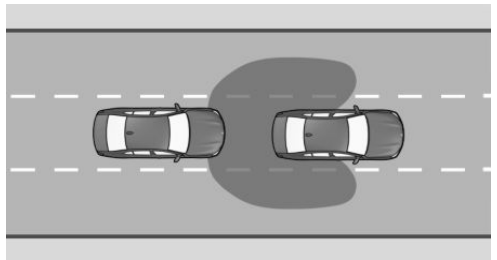

Radar sensors monitor the area behind the vehicle.

If a vehicle is approaching from behind at a relevant speed, the system can respond as follows:

- ▶ The hazard warning lights are switched on if appropriate.
- ▶ PreCrash functions are triggered if appropriate.

Safety notes

Follow the safety information in the Chapter “Collision warning systems”.

Sensors

The system is controlled via the radar sensors at the side in the rear.

Turning the Rear Collision Prevention on/off

The system is automatically activated at the start of each journey.

The system is deactivated in the following situations:

- ▶ When reversing.
- ▶ If the trailer socket is occupied or trailer operation is activated, for example when operating with a trailer or bicycle carrier.

System limits

General

Follow the limits of the system in the chapter “Collision warning systems”.

Functional limitations

The system may have restricted functionality in the following situations:

- ▶ The speed of the approaching vehicle is much faster than your own speed.
- ▶ The approaching vehicle is approaching slowly.

Road Priority Warning

Principle

The Road Priority Warning provides support in situations where road signs or traffic lights indicate that the driver must give way.

General

The system uses a camera behind the windscreen to evaluate the road signs and traffic lights.



The navigation system forwards information regarding the road layout to the system.

A warning is given if a right-of-way is about to be violated in the following traffic situations, for example:

- ▶ At a road junction.
- ▶ At a T-junction.
- ▶ On a slip road.
- ▶ At a roundabout.
- ▶ In the event of a red traffic light.

Starting from a variable minimum speed, the system issues warnings from and up to approximately 75 km/h, approx. 47 mph.

The following road signs are taken into account for the Road Priority Warning:

Signs	Meaning
	Give way signs: These signs trigger an advance warning.
	Stop signs. These signs trigger an advance warning and an acute warning.
	Red traffic lights trigger an advance warning and an acute warning.

Safety notes

Follow the safety information in the Chapter "Collision warning systems".

Operating requirements

The road priority situation must be unambiguously directed by road signs or light signal systems.

Sensors

The system is controlled by the camera behind the windscreen.

Turning the Road Priority Warning on/off

1. "MENU"
2. "Vehicle apps"
3. "Driving settings"
4. "Driver assistance"
5. "Safety and warnings"
6. "Give way warning"
7. Select the desired setting.

Setting the warning time

1. "MENU"
2. "Vehicle apps"
3. "Driving settings"
4. "Driver assistance"
5. "Safety and warnings"
6. "Give way warning"
7. Select the desired setting.
 - ▷ "Early"
 - ▷ "Medium"
 - ▷ "Late": only acute warnings are displayed.

Warning function

General



The system warns in two stages:

- ▷ Advance warning: visually by means of an icon in the instrument cluster.
- ▷ Acute warning: visually by means of an icon in the instrument cluster and with an additional acoustic signal.

The timing of the warnings may vary depending on the current driving situation and the set warning time.

Advance warning



If there is a risk that road priority is about to be ignored, one of the following icons appears in the instrument cluster:

Icon	Meaning
	Give way.
	Stop.
	Red traffic light.

When an advance warning is issued, intervene as appropriate for the situation; for example, by braking.

Acute warning

If there is an imminent risk that right-of-way is about to be ignored, an acoustic signal sounds and one of the following icons appears in the instrument cluster:

Icon	Meaning
	Stop.
	Red traffic light.

When an acute warning is issued, immediately intervene as appropriate for the situation; for example, by braking.

Display in the Head-up display

Depending on the equipment, the warning is displayed in the Head-up display at the same time as in the instrument cluster.

System limits

General

Follow the limits of the system in the chapter “Collision warning systems”.

No Warning

The system provides no warning in situations such as the following:

- ▶ In road priority situations without “Give Way” signs, “Stop” signs or red light signal systems.
- ▶ At road junctions with relevant traffic lights that illuminate yellow or green.

Functional limitations

The system may have restricted functionality in situations such as the following:

- ▶ If road signs or light signal systems are unclear.
- ▶ If road signs or light signal systems are fully or partially concealed or soiled.
- ▶ If road signs or light signal systems are difficult to read or rotated.
- ▶ If road signs or light signal systems are too small or too large.
- ▶ When the road signs do not correspond to the standard.
- ▶ If road signs are detected that apply to a merging or parallel road.
- ▶ If the road signs or road layouts are specific to one country.
- ▶ At road junctions with flashing light signal systems.
- ▶ Up to 10 seconds after switching on drive-ready state using the Start/Stop button.

- ▶ In the case of navigation data that is invalid, outdated or not available.
- ▶ The system may not be available or may only be available to a limited extent in some countries.

Wrong-way Warning

Principle

The Wrong-way Warning issues a warning if the driver is about to drive the wrong way, for example on motorways, roundabouts and one-way streets.

General

Depending on the equipment, the system will check the traffic situation based on navigation data and road signs.

The system will take into account road signs such as the following:

- ▶ No entry.
- ▶ Roundabout.
- ▶ Direction arrows: keep right/left signs.

Safety notes

Follow the safety information in the Chapter “Collision warning systems”.

Operating requirements

The road layout ahead must be unambiguously indicated by road signs.

Sensors

The system is controlled by the camera behind the windscreen.

Turning Wrong-way Warning on/off

Depending on the national-market version, the Wrong-way Warning is automatically activated after each start of the journey.

If Collision Warning is temporarily turned off, the Wrong-way Warning is also turned off.

Warning function



A warning is displayed and an acoustic signal sounds, for example when the vehicle is travelling in the wrong direction on a motorway, roundabout or one-way street.

Warnings are displayed in the instrument cluster and, depending on the equipment, in the Head-up display.

System limits

General

Follow the limits of the system in the chapter "Collision warning systems".

No Warning

The system provides no warning if the road layout is not indicated by road signs, for example.

Functional limitations

The system may have restricted functionality, or give no Wrong-way Warning at all, in situations such as the following:

- ▶ If the road signs are ambiguous.
- ▶ If the road signs are fully or partially covered or soiled.
- ▶ If the road signs are poorly visible or twisted.
- ▶ If the road signs are too small or too large.
- ▶ When the road signs do not correspond to the standard.
- ▶ If road signs are detected that apply to a merging or parallel road.
- ▶ If the road signs or road layouts are specific to one country.
- ▶ Up to 10 seconds after switching on drive-ready state using the Start/Stop button.

- ▶ In the case of navigation data that is invalid, outdated or not available.
- ▶ It may not be possible to use the system in all countries.

Emergency Stop Assistant

Principle

If the driver is no longer capable of driving, the Emergency Stop Assistant helps to bring the vehicle safely to a standstill.

General

The emergency stop function is not triggered automatically. The emergency stop function can only be triggered manually by the vehicle occupants.

If the system is activated, the vehicle is brought to a standstill within its own lane by means of lane tracking.

Depending on the equipment and national-market version, the system may have a lane change function.

With lane change function: on motorways or similar roads, the system steers the vehicle to the hard shoulder if possible. On other roads or in heavy traffic, the vehicle is brought to a standstill in the road it is currently in.

Overview

Button in the vehicle

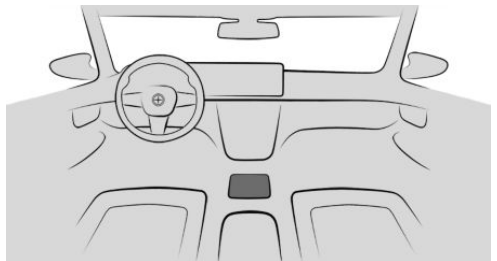



Parking brake

Operating requirements

- ▶ The function can be activated at speeds of 10 km/h, approx. 6 mph to approx. 250 km/h, approx. 155 mph.
- ▶ With lane change function: lane changes are performed if the traffic situation allows.

Activating the emergency stop function



Briefly press the switch for the parking brake to activate the emergency stop function.

- ▶ With lane change function: when the switch is released, an automatic lane change is triggered if necessary.
- ▶ The system takes over vehicle control for a maximum of 2 minutes.
- ▶ The hazard warning lights are switched on.
- ▶ An emergency call is triggered.

Cancelling the emergency stop function

At any time during the process, the driver can cancel the emergency stop function by actively taking control of the vehicle.

For example, the emergency stop function is cancelled in the following situations:

- ▶ When the steering wheel is turned.
- ▶ On indicating.
- ▶ When the accelerator pedal is pressed.
- ▶ When the hazard warning lights are switched off.
- ▶ When the emergency call is cancelled.
- ▶ When the selector lever position is changed while at a standstill.
- ▶ The parking brake switch is pressed.

When the vehicle is at a standstill







As soon as the vehicle is at a standstill, the system configures the following settings:

- ▶ The vehicle is secured to prevent it from rolling away.
- ▶ The interior lights are switched on.
- ▶ The central locking system is unlocked.

Displays in the instrument cluster

Icon	Status
	Emergency stop function active.

Without lane change function:

Icon	Status
	Steering wheel icon green: If lane boundaries are detected, the system keeps the vehicle in the lane.
	Steering wheel icon grey: Lane tracking interrupted briefly.
	Steering wheel icon yellow: Lane marking driven over. If lane boundaries are detected, the system keeps the vehicle in the lane.
	Steering wheel icon yellow: Hands are not around the steering wheel. System remains active.
	Red steering wheel icon, acoustic signal sounds: Hands are not around the steering wheel. Interruption of lane tracking is imminent.
	Red steering wheel icon, acoustic signal sounds: Lane tracking is switched off.

System limits

Only use the system if the driver is no longer able to operate the vehicle.

The system cannot replace the abilities of a driver who is capable of driving.

Crossing-traffic Warning

Principle

At blind exits or when leaving bay parking spaces, the Crossing-traffic Warning detects other road users approaching from the side earlier than is possible from the driver's seat.

General

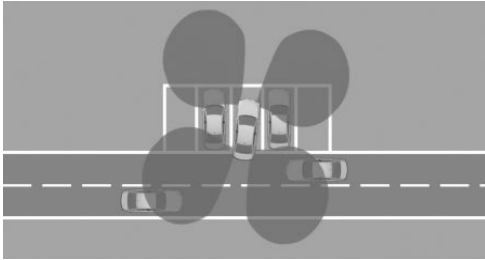

The area behind to the vehicle is monitored by sensors.

Depending on the equipment, the area in front of the vehicle is also monitored.

The system indicates when other road users are approaching.

Follow the information in the Chapter "Parking assistance systems".

Safety note

WARNING

The system does not relieve you of your personal responsibility to assess the traffic situation correctly. Due to system limits, it cannot respond independently and appropriately in all traffic situations. There is a risk of accident.

Adapt your driving style to the traffic conditions. In addition, look directly to check the traffic situation and the vehicle surroundings and intervene actively where appropriate.

Sensors

The system is controlled using the following sensors:

- ▷ Side radar sensors, rear.
- ▷ Depending on the equipment: side radar sensors, front.

Turning on/turning off the Crossing-traffic Warning manually

1. "MENU"
2. "Vehicle apps"
3. "Driving settings"
4. "Driver assistance"
5. "Parking and manoeuvring"
6. "CROSSING-TRAFFIC WARNING"
7. Select the desired setting.

Turning on the Crossing-traffic Warning automatically

If the system was activated on the control display, it is automatically turned on as soon as the Park Distance Control or a camera view is active and a selector lever position is engaged.

The system is switched on at the rear when reverse gear is engaged.

Depending on the equipment, the front system is turned on when a drive position is engaged.

Depending on the national-market version, the system is automatically active when the vehicle is started.

Turning off the Cross-traffic Warning automatically

The system is automatically turned off, for example, in the following situations:

- ▶ If walking speed is exceeded.
- ▶ When a certain distance covered is exceeded.

Warning function

General

The control display shows the corresponding image, an acoustic signal sounds, if necessary, and the light in the exterior mirror flashes.

Visual warning

Light in the exterior mirror



The light in the exterior mirror flashes if other vehicles are detected by the rear sensors when the vehicle is reversing.

Display in the Park Distance Control view

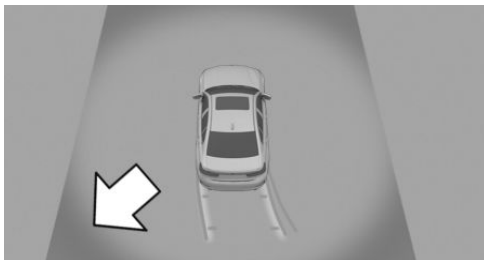

In the Park Distance Control view, the relevant boundary area flashes red if the sensors detect vehicles.

Depending on the equipment: display in the camera image

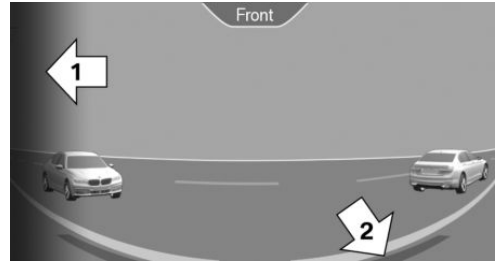

Depending on the direction of travel, the view to the front or rear is displayed in the camera image.

The relevant boundary area, arrow 1, in the camera view flashes red if the sensors detect vehicles.

Yellow lines, arrow 2, indicate the bumper of your vehicle.

Acoustic warning

In addition to the visual warning, an acoustic signal sounds if your own vehicle moves into the respective direction.

Depending on the national-market version, the acoustic signal will already sound when the drive position is engaged.

System limits

System limits of the sensors

For further information:

Sensors in the vehicle, see page 47.

Functional limitations

The function can be restricted, for example, in the following situations:

- ▶ On sharp bends.
- ▶ Crossing objects are moving at a very slow or a very fast speed.

- ▷ Other objects that hide cross traffic are in the capture range of the sensors.
- ▷ If the trailer socket is occupied or the trailer mode is activated, the Cross-traffic Warning is not available for the area behind the vehicle.

Dynamic brake lights

Principle

The brake lights flash to warn road users behind the vehicle that emergency braking is being performed.

General



- ▷ Normal braking: brake lights illuminate.
- ▷ Heavy braking: brake lights flash.

Shortly before the vehicle comes to a standstill, the hazard warning lights are activated.

To switch off the hazard warning lights:

- ▷ Accelerate.
- ▷ Press the hazard warning lights button.

BMW Drive Recorder

Principle

The BMW Drive Recorder saves short video recordings of the vehicle surroundings in order to document the traffic situation, for example.

General

There are various ways of saving video recordings.

- ▷ Automatic saving of recordings.
The function makes it possible to document the circumstances of an accident.
- ▷ Manual saving of recordings.
The function makes it possible to document traffic situations.

Cameras of the parking view are used, for example Panorama View.

In addition, the following journey parameters are saved:

- ▷ Date.
- ▷ Time.
- ▷ Speed.
- ▷ GPS coordinates.

Data protection

The reliability of the recording and the use of video recordings depend on the legal regulations in the country where the system is to be used. The user is responsible for the use of the system and for complying with the provisions that apply in each case.

Before using for the first time, the vehicle manufacturer recommends checking that there are no legal or official restrictions on using the system in the state or country in question. Additionally, the legality of using the system should be checked at regular intervals, especially if the vehicle frequently crosses borders.

Other drivers of the vehicle must be informed of the system. Information about the system must also be provided if the vehicle is passed on to anyone else.

Operating requirements

- ▷ BMW Drive Recorder is activated.
- ▷ Privacy Policy has been accepted.

- ▶ Recording type was selected.
- ▶ Recording duration was selected.

Activating/deactivating the BMW Drive Recorder

The BMW Drive Recorder must be activated before using the recording function for the first time.

1. "MENU"
2. "All apps"
3. "Drive Recorder"
4. Accept data protection policy.
5. "Settings"
6. "Allow recording"
7. Select the desired setting.

Recording functions

Automatic recording

The recording is saved automatically when the vehicle sensors detect an accident.

The system records for up to 20 seconds before and after the save function was triggered.

Manual recording

Using the button

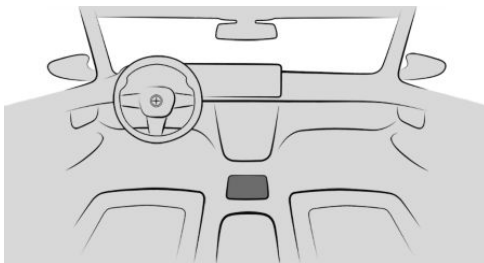

Press and hold the button.

Via iDrive

Start the recording:

1. "MENU"
2. "All apps"
3. "Drive Recorder"
4. "Recording"
5. "Start recording"

The recording can also be started using the widget on the control display.

The system saves the recordings up to 20 seconds before and after the save function was triggered.

Playing and managing recordings

Saved video recordings can be played, exported and deleted.

For your own safety, the video recording is only shown on the control display if the speed is below approximately 3 km/h, 2 mph. In the case of some national-market versions, the video recording is only shown with the parking brake applied or with the selector lever in position P.

1. "MENU"
2. "All apps"
3. "Drive Recorder"
4. "Recordings"
5. Select the desired recording.
6. Select the desired setting.

If the cameras switched during the recording, it is possible to select different sections of the video.

Settings

General

Various settings can be made.

Recording type

1. "MENU"
2. "All apps"

3. "Drive Recorder"
4. "Settings"
5. Select the desired setting.

Recording duration

1. "MENU"
2. "All apps"
3. "Drive Recorder"
4. "Settings"
5. Select the desired setting.

Cameras

Different cameras can be selected.

1. "MENU"
2. "All apps"
3. "Drive Recorder"
4. "Settings"
5. "Camera selection"
6. Select the desired camera.

In the event of an accident, the system switches to "All" cameras automatically.

If driver assistance systems are active, their camera views are selected automatically.

System limits

In the event of a serious accident, recordings may not be saved if, for example, the damage to the vehicle is too extensive or the power supply was interrupted.

Active Protection

Principle

In critical situations, Active Protection prepares the passengers and the vehicle for a potential imminent accident.

General

Depending on the equipment and the national-market version, Active Protection consists of different PreCrash functions.

The system detects critical driving situations which could potentially lead to an accident. Such critical driving situations include:

- ▷ Full braking.
- ▷ Severe understeering.
- ▷ Severe oversteering.

Certain functions of some systems installed in the vehicle can – within the system limits – cause Active Protection to trigger:

- ▷ Collision Warning with braking function: automatic brake intervention.
- ▷ Collision Warning with braking function: brake power assistance.
- ▷ Rear Collision Prevention: detection of potential rear collisions.

Safety note

WARNING

The system does not relieve you of your personal responsibility. System limitations may mean that critical situations are not detected reliably or in good time. There is a risk of accident. Adapt your driving style to the traffic conditions. Observe the traffic situation and intervene actively if the situation warrants it.

Function

If fastened, the driver's and front passenger's seat belt strap is automatically tensioned once when driving off.

In critical accident situations, the following individual functions become active as required:

- ▶ Automatic pre-tensioning of the front seat belts.
- ▶ Automatic closing of the windows, leaving just a small gap.
- ▶ For glass sunroof: automatic closing of glass sunroof, including sun protection.
- ▶ For panoramic glass sunroof: automatic closing of the panoramic glass sunroof, including sun protection.
- ▶ With comfort seat in the front: automatic positioning of the backrest of the front passenger seat.
- ▶ With comfort seats in the rear: automatic positioning of the rear seat backrests.

If the critical driving situation passes without an accident occurring, the tension in the front seat belts is slackened again. If the belt tension does not slacken automatically, stop the vehicle and unfasten the seat belt by pressing the red button on the seat belt buckle. Fasten the seat belt again before continuing driving. All other systems can be restored to the desired setting.

PostCrash – iBrake

Principle

In certain accident situations, PostCrash can automatically bring the vehicle to a standstill without an intervention from the driver.

General

PostCrash can reduce the risk of a further collision and its consequences.

At a standstill

Once the vehicle has come to a halt, the brake is released automatically.

Harder vehicle deceleration

In certain situations, it may be necessary to bring the vehicle to a standstill more quickly than is possible with automatic braking.

To do so, brake quickly and firmly. For a brief period, the braking pressure will be higher than that achieved with the automatic braking function. Automatic braking is interrupted.

Cancelling automatic braking

In certain situations, it may be necessary to cancel automatic braking, for example if evasive action is required.

Cancel automatic braking:

- ▶ By depressing the brake pedal.
- ▶ By depressing the accelerator pedal.

Attentiveness Assistant

Principle

The Attentiveness Assistant can detect decreasing attentiveness or the onset of fatigue in the driver on long monotonous journeys, for example on motorways. The system recommends taking a break.

Safety note

WARNING

The system does not relieve you of your personal responsibility to assess your physical condition correctly. Increasing inattention or fatigue might not be detected, or may not be detected in good time. There is a risk of accident. Make sure that the driver is rested and alert. Adapt your driving style to the traffic conditions.

Function

The system is switched on every time drive-ready state is switched on.

Once the journey has started, the system adapts to the driver so that any decrease in attention or fatigue can be detected.

This process considers the following criteria:

- ▷ Personal driving style, for example steering.
- ▷ Driving conditions, for example time of day, duration of journey.
- ▷ Depending on the equipment: attentiveness of the driver through the Driver Attention Camera.

The system is active from approx. 70 km/h, 43 mph and can also display a recommendation to take a break.

Break recommendations

Setting break recommendations

The Attentiveness Assistant is automatically active every time drive-ready state is switched on and can therefore display break recommendation.

Break recommendation can also be switched on or off and adjusted via iDrive.

1. "MENU"
2. "Vehicle apps"
3. "Driving settings"
4. "Driver assistance"
5. "Safety and warnings"
6. "Attentiveness Assistant"
7. Select the desired setting.

Display

If the driver shows signs of decreasing attentiveness or of fatigue, a note is shown on the control display with the recommendation to take a break.

The following settings can be selected during the display.

After a break, another break recommendation cannot be displayed until after approximately 45 minutes at the earliest.

System limits

The system may have restricted functionality, or give no warning at all, in situations such as the following:

- ▷ If the time is set incorrectly.
- ▷ When the speed is predominantly below approx. 70 km/h, 43 mph.
- ▷ If a sporty driving style is adopted, for example sharp acceleration or fast cornering.
- ▷ In active driving situations, for example frequent lane changes.
- ▷ In poor road condition.
- ▷ In strong crosswinds.

The system is reset approximately 45 minutes after the vehicle is stopped, for example when taking a break during a long motorway journey.

Driver Attention Camera

Principle

Depending on the equipment, a camera in the instrument cluster monitors the driver activity or the driver's direction of view.

General

For support by assistance systems, the attention of the driver is analysed by evaluating the head position and eye opening of the driver.

To guarantee full functionality, ensure that the Driver Attention Camera has an unobstructed field of view.

For further information:

- ▷ Attentiveness Assistant, see page [217](#).
- ▷ Steering and Lane Control Assistant with Assisted Driving Plus, see page [244](#).

Overview

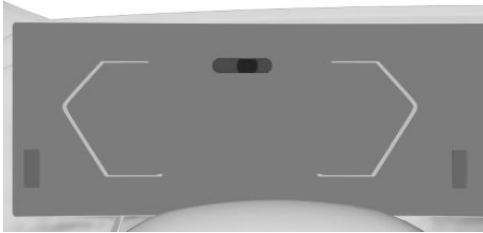

Depending on the equipment, the instrument cluster has up to 3 infrared light sources. Depending on the light conditions, they can be visible when the vehicle is in the standby state.

System limits

The Driver Attention Camera may have restricted functionality in situations such as the following:

- ▶ If the Driver Attention Camera is covered by the steering wheel.
- ▶ If the driver is wearing sunglasses with high protection against infrared light.

Driving stability control systems

Vehicle equipment

This chapter describes equipment, systems and functions which are offered or will be offered on a model-specific basis, even if they are not included in the vehicle in question.

For further information:

Vehicle equipment, see page 7.

Anti-lock Braking System ABS

Principle

The Anti-lock Braking System ABS prevents the wheels from locking when the brakes are applied.

Steering control is retained even during full braking, which enhances active road safety.

ABS is operational each time the drive-ready state is switched on.

Brake Assist

When the brake is pressed quickly, Brake Assist automatically provides the maximum possible braking force assistance. This keeps the stopping distance as short as possible in full braking situations. The advantages offered by the Anti-lock Braking System ABS are utilised in this case.

The pressure on the brake should be maintained for the duration of the full-braking process.

Adaptive brake assist

In combination with Cruise Control with distance control, this system ensures that the brakes re-

spond even more rapidly when braking in critical situations.

Dynamic Stability Control

Principle

The Dynamic Stability Control helps to keep the vehicle on a steady course by reducing drive power and by brake intervention on individual wheels.

General

The system detects the following unstable driving conditions, for example:

- ▶ Loss of traction at the rear which can lead to oversteering.
- ▶ Loss of grip at the front wheels which can lead to understeering.

Safety notes

WARNING

The system does not relieve you of your personal responsibility to assess the traffic situation correctly. Due to system limitations, it cannot respond independently and appropriately in all traffic conditions. There is a risk of accident. Adapt your driving style to the traffic conditions. Observe the traffic situation and intervene actively if the situation warrants it.

WARNING

When driving with a roof load, for example with a roof rack, the higher centre of gravity can mean that driving safety is no longer guaranteed in critical driving situations. There is a risk of accident or material damage. Driving with

roof load only with activated Dynamic Stability Control.

Overview

Button in the vehicle

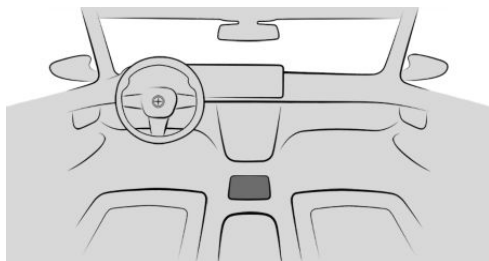

DSC OFF



Activating/deactivating Dynamic Stability Control

General



Driving stability during acceleration and cornering is restricted if Dynamic Stability Control is deactivated.

To assist driving stability, re-activate Dynamic Stability Control as soon as possible.

Deactivating the system

1.  Press the button.
2. "DSC OFF"
3. "Activate anyway"
4. Press the  button to close the selection.

Activating the system

1.  Press the button.
2. "DSC ON"
3. Press the  button to close the selection.

After switching on drive-ready state, Dynamic Stability Control is activated.

Display

In the instrument cluster

"DSC OFF": display in the instrument cluster with deactivated Dynamic Stability Control.

Indicator and warning lights

 Indicator light is illuminated: Dynamic Stability Control is deactivated.

 Indicator light flashes: Dynamic Stability Control controls the drive and brake forces. The vehicle is being stabilised.

Decrease speed and adjust driving style to the road conditions.

Indicator light is illuminated: Dynamic Stability Control malfunction or initialising. No driving stabilisation.

Have the system checked immediately by a Service Partner of the manufacturer or another qualified Service Partner or a specialist workshop.

Automatic programme change

Dynamic Stability Control can be activated automatically by the front-collision warning, depending on the situation.

Dynamic Traction Control

Principle

Dynamic Traction Control is a drive-optimised variant of Dynamic Stability Control.

In special road conditions, for example on un-cleared, snow-covered roads or on loose surfaces, the system ensures maximum drive, but with restricted driving stability.

General

Activating Dynamic Traction Control provides maximum traction. Driving stability is restricted when accelerating and cornering.

Activating Dynamic Traction Control briefly may be useful in the following situations:

- ▷ When driving in slush or on un-cleared, snow-covered roads.
- ▷ When driving off in deep snow or on a loose surface.
- ▷ When driving with snow chains.

Overview

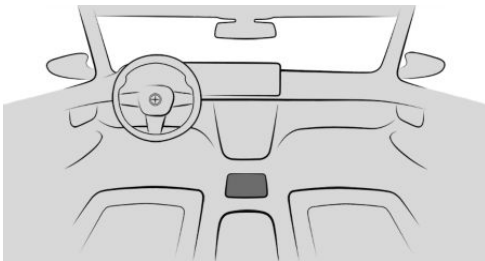

Button in the vehicle





DSC OFF

Activating/deactivating Dynamic Traction Control

To activate the system

1. Press the  button to open the selection.
2. "Traction"
3. "Activate traction"
4. Press the  button to close the selection.

Deactivating the system

1. Press the  button to open the selection.
2. "DSC ON"
3. Press the  button to close the selection.

Display

In the instrument cluster

When Dynamic Traction Control is activated, TRACTION is displayed in the instrument cluster.

Indicator and warning lights



Indicator light illuminates: Dynamic Traction Control is activated.

Automatic programme change

In certain situations, Dynamic Stability Control is activated automatically:

- ▶ Active Cruise Control with distance control is activated.
- ▶ In case of a brake intervention by the front-collision warning.
- ▶ In the event of a flat tyre.

spective of the current speed, the variable sport steering reacts to the angle of the steering wheel with varying steering ratios.

xDrive

Principle

xDrive is the all-wheel drive system of the vehicle. Concerted action by the xDrive and other suspension control systems, for example, Dynamic Stability Control, further optimises traction and driving dynamics.

General

xDrive distributes the driving power variably to the front and rear axles according to the driving situation and road condition.

Efficient4x4 reduces consumption by deploying all-wheel drive as required.

Servotronic

Principle

Servotronic is a speed-dependent steering assistance.

The system provides more steering force assistance at lower speeds than at higher speeds. This makes it easier to park, for example, and provides a firmer steering feel when driving at higher speeds.

In addition, the steering force is adapted according to the drive mode, so that a firm, sporty feel or a comfortable steering response is conveyed.

Variable sport steering

The variable sport steering facilitates a direct and agile driving style with less steering effort. Irre-

Driver assistance systems

Vehicle equipment

This chapter describes equipment, systems and functions which are offered or will be offered on a model-specific basis, even if they are not included in the vehicle in question.

For further information:

Vehicle equipment, see page 7.

Speed limit warning

Principle

The speed limit warning can be used to set a speed limit. A warning will be issued when this speed limit is exceeded.

General

The warning is repeated if the set speed limit is exceeded again after dropping below it by 5 km/h/3 mph.

Activating/deactivating the speed limit warning

1. "MENU"
2. "Vehicle apps"
3. "Driving settings"
4. "Driver assistance"
5. "Safety and warnings"
6. "Speed warning"

Setting the speed

1. "MENU"
2. "Vehicle apps"
3. "Driving settings"
4. "Driver assistance"
5. "Safety and warnings"

6. "Speed warning"
7. "Warning at:"
8. Select the desired setting.

Setting the current speed as the speed limit warning

1. "MENU"
2. "Vehicle apps"
3. "Driving settings"
4. "Driver assistance"
5. "Safety and warnings"
6. "Speed warning"
7. "Adopt current speed"

Manual Speed Limiter

Principle



The Manual Speed Limiter can be used to set a speed limit, for instance, to prevent the vehicle from exceeding speed limits.

General

The system allows speeds of 30 km/h/20 mph and above to be set as a speed limit. Below the set speed limit, the vehicle can be driven without restriction.

Overview

Buttons on the steering wheel

Button	Function
	System on/off.
	To store the current speed. Speed Limit Assist: to accept the suggested speed manually.
	Rocker switch: To change the speed limit.

Operation

Turning on the speed limiter

 Press the button on the steering wheel.

The current speed is adopted as the speed limit. When switching on at a standstill or driving at low speed, 30 km/h/20 mph is set as the speed limit. The speedometer marker is set to the appropriate speed.

When the speed limit is activated, Dynamic Stability Control may be switched on and the drive mode may be changed.

Turning off the speed limiter

 Press the button on the steering wheel.

The system switches off automatically in situations such as the following:

- ▶ When drive-ready state is switched off.
- ▶ When switching on Cruise Control.
- ▶ When activating some programmes using Driving Experience Control.

The displays turn off.

To interrupt the speed limiter

The system is interrupted in reverse gear or when rolling backwards at idle.

Changing the speed limit



Press the rocker switch repeatedly up or down until the desired speed limit is set.

- ▶ Each time the rocker switch is tapped to the resistance point, the speed limit is increased or decreased by 1 km/h, 1 mph.
- ▶ Each time the rocker switch is pressed beyond the resistance point, the speed limit changes to the next multiple of 10 km/h on the km/h display or the next multiple of 5 mph on the mph display in the speedometer.

If the set speed limit is reached or unintentionally exceeded, for example when driving downhill, there is no active brake intervention.

If you set a speed during the journey which is below the current speed, the vehicle decelerates to the set speed limit.

The current speed can also be stored by pressing the button:

 Press the button on the steering wheel.

Exceeding of speed limit

The system gives a warning if the vehicle's speed exceeds the set speed limit.

You can intentionally exceed the speed limit.

To intentionally exceed the set speed limit, press the accelerator pedal all the way down.

The limit automatically becomes active again as soon as the current speed falls below the set speed limit.

Warning when the speed limit is exceeded

Visual warning



If the speed limit is exceeded: the indicator light in the instrument cluster flashes for as long as the set speed limit is exceeded.

Acoustic warning

- ▷ A warning sounds if you inadvertently exceed the set speed limit.
- ▷ If the speed limit is reduced to below the driven speed during the journey, the signal sounds after a little time.
- ▷ No signal sounds if you intentionally exceed the speed limit by fully pressing the accelerator pedal.

Displays in the instrument cluster

Display in the speedometer

Depending on the equipment, a mark in the speedometer displays the status of the system.



- ▷ Green marker: system is active.
- ▷ Grey mark: the system is interrupted.
- ▷ No marker: system is switched off.

Indicator light



- ▷ Indicator light illuminates: the system is switched on.
- ▷ Indicator light flashes: set speed limit is exceeded.
- ▷ Grey indicator light: the system is interrupted.

Cruise Control without distance control

Principle

Cruise Control allows a set speed to be specified using the buttons on the steering wheel. The set speed is then maintained by the system. It does this by automatically accelerating and braking the vehicle as necessary.

General

The system can be activated from 30 km/h/20 mph.

Depending on the vehicle setting, the characteristics of Cruise Control may change in certain areas, for example acceleration in ECO PRO drive mode is less pronounced.

Safety notes

WARNING

The system does not relieve you of your personal responsibility to assess the traffic situation correctly. Due to system limitations, it cannot respond independently and appropriately in all traffic conditions. There is a risk of accident. Adapt your driving style to the traffic conditions. Observe the traffic situation and intervene actively if the situation warrants it.

WARNING

The risk of an accident may increase if the system is used in certain situations, such as:

- ▷ On stretches of road with many corners and bends.
- ▷ In heavy traffic.
- ▷ If the road is icy, if there is fog or snow, in wet conditions or on a loose road surface.







There is a risk of accident or material damage. Only use the system if it is possible to drive at a constant speed.

WARNING

The desired speed may be set incorrectly by mistake or called up accidentally. There is a risk of accident. Adjust the desired speed to the traffic conditions. Observe the traffic situation and intervene actively if the situation warrants it.

Overview

Buttons on the steering wheel

Button	Function
	Cruise Control on/off.
	
	To resume Cruise Control with last setting.
	To interrupt Cruise Control.
	To store the current speed. Speed Limit Assist: to accept the suggested speed manually.
	Rocker switch: To set the speed.

Turning the Cruise Control on/off

Turning on the system



Depending on the equipment, press the corresponding button on the steering wheel.

The indicator lights are illuminated in the instrument cluster and the marker in the speedometer is positioned at the current speed.

Cruise Control is active. The driven speed is maintained and stored as the set speed.

If necessary, the Dynamic Stability Control will be turned on.

Switching the system off



Depending on the equipment, press the corresponding button on the steering wheel.



The displays turn off. The stored set speed is deleted.

To interrupt Cruise Control

Manually interrupting the system



Press the button while the system is activated.

Interrupting the system automatically

The system is interrupted automatically in the following situations:

- ▶ When braking manually.
- ▶ Selector lever position D is disengaged.
- ▶ Dynamic Traction Control is activated or Dynamic Stability Control is deactivated.
- ▶ The Dynamic Stability Control adjusts.

Setting the speed

Maintaining and saving the speed

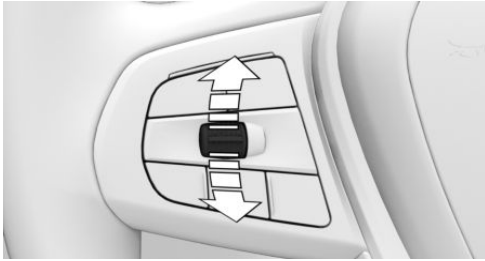

While the system is interrupted, press the rocker switch up or down once.

When the system is switched on, the current speed is maintained and stored as the set speed. The stored speed is displayed on the speedometer.

If necessary, the Dynamic Stability Control will be turned on.

The speed can also be stored by pressing the button.

SET

Press the button.

Changing the speed

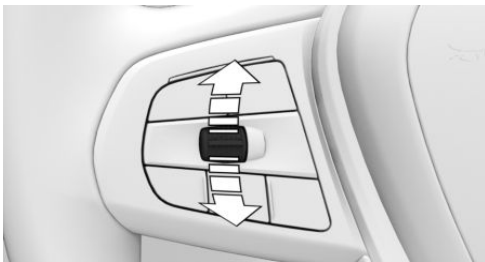

Press the rocker switch repeatedly up or down until the set speed is set.

If the system is active, the displayed speed is stored and the vehicle adjusts to the stored speed when the road is clear.

- ▶ Each time the rocker switch is tapped to the resistance point, the set speed is increased or decreased by 1 km/h, 1 mph.
- ▶ Each time the rocker switch is pressed beyond the resistance point, the set speed changes to the next multiple of 10 km/h on the km/h display or the next multiple of 5 mph on the mph display in the speedometer. The maximum speed which can be set depends on the vehicle.

- ▶ When the rocker switch is pressed to the resistance point and then held there: the vehicle accelerates or decelerates without the need to press the accelerator pedal.

When the rocker switch is released, the vehicle maintains the final speed. Pressing beyond the resistance point accelerates the vehicle more rapidly.

Resuming Cruise Control

If Cruise Control is interrupted, it can be resumed by calling up the stored speed.

Before calling up the stored speed, make sure that the difference between the current speed and the stored speed is not too great. Otherwise, there may be unintentional deceleration or acceleration.

RESUME With the system interrupted, press the button.

Cruise Control is resumed with the stored values. In the following instances, the stored speed value is deleted and therefore cannot be called up again:

- ▶ When the system is switched off.
- ▶ When drive-ready state is switched off.

Displays in the instrument cluster

Display in the speedometer

Depending on the equipment, a mark in the speedometer displays the status of the system.



- ▶ Green marker: system is active, the marker shows the set speed.
- ▶ Grey marker: system is interrupted; the marker shows the stored speed.
- ▶ No marker: system is switched off.

Indicator light



- ▶ Green indicator light: the system is active.
- ▶ Grey indicator light: the system is interrupted.
- ▶ No indicator light: the system is switched off.

Displays in the Head-up display

Some information from the system can also be shown in the Head-up display.



The icon is displayed when the selected set speed has been reached.

System limits

The set speed is also maintained when driving downhill. The vehicle may not achieve the set speed on uphill gradients if there is not enough drive power.

In ECO PRO drive mode, it is possible that the vehicle will drive faster or slower than the set speed setting in some situations, for example on downhill or uphill gradients.

Active Cruise Control with distance control

Principle

Active Cruise Control allows the driver to specify a set speed and a desired distance from the vehicle in front, using the buttons on the steering wheel.

General

When the road ahead is clear, the system maintains the set speed. The vehicle accelerates or brakes automatically.

If there is a vehicle driving in front, the system adapts the speed of your vehicle in order to maintain the set distance from the vehicle ahead. The speed is adapted as far as the given situation allows.

The distance can be set in several stages and for safety reasons is dependent on the respective speed.

If the vehicle ahead brakes to a standstill and sets off again shortly afterwards, the system is able to comprehend this as far as the given conditions allow.

Otherwise, drive off yourself, for example by pressing the accelerator pedal or rocker switch on the steering wheel.

Depending on the vehicle setting, the characteristics of Cruise Control may change in certain areas, for example acceleration in ECO PRO drive mode is less pronounced.

Safety notes

WARNING

The system does not relieve you of your personal responsibility to assess the traffic situation correctly. Due to system limitations, it cannot respond independently and appropriately in all traffic conditions. There is a risk of accident. Adapt your driving style to the traffic conditions. Observe the traffic situation and intervene actively if the situation warrants it.

WARNING

An unsecured vehicle can start moving and rolling away. There is a risk of accident. Before leaving the vehicle, secure it to prevent it from rolling away.

Observe the following to ensure that the vehicle is secured against rolling away:

- ▷ Apply the parking brake.
- ▷ Turn the front wheels towards the kerb on upward or downward gradients.
- ▷ Additionally secure the vehicle on upward or downward gradients, for example with a chock.

WARNING

The desired speed may be set incorrectly by mistake or called up accidentally. There is a risk of accident. Adjust the desired speed to the traffic conditions. Observe the traffic situation and intervene actively if the situation warrants it.

WARNING











There is a risk of accident if the difference in speed relative to other vehicles is too great. This may occur, for example, in the following situations:

- ▷ When quickly approaching a slowly moving vehicle.
- ▷ If another vehicle suddenly veers into the vehicle's own lane.
- ▷ When quickly approaching stationary vehicles.

There is a risk of injury or even death. Observe the traffic situation and intervene actively if the situation warrants it.

Overview

Buttons on the steering wheel

Button	Function
	With Steering and Lane Control Assistant: Cruise Control on/off.
	With Steering and Lane Control Assistant: To select the function.
	Without Steering and Lane Control Assistant: Cruise Control on/off.
	To store the current speed. Speed Limit Assist: to accept the suggested speed manually.
	With Steering and Lane Control Assistant: To interrupt Cruise Control. To resume Cruise Control with last setting.
	Without Steering and Lane Control Assistant: To resume Cruise Control with last setting.
	Without Steering and Lane Control Assistant: To interrupt Cruise Control.
	To increase the distance. To switch distance control on/off.
	To reduce the distance. To switch distance control on/off.
	Rocker switch: To set the speed.

Sensors

The system is controlled using the following sensors:

- ▶ Cameras behind the windscreen.
- ▶ Front radar sensor.

For further information:

Sensors in the vehicle, see page 47.

Use

The system can be used to optimum effect on well-constructed roads.

The minimum speed that can be set is 30 km/h/20 mph.

The maximum speed which can be set is limited and depends on the vehicle and its equipment, for example.

Higher speeds can be set by switching to Cruise Control without distance control.

The system can also be activated when the vehicle is at a standstill.

Turning the Cruise Control on/off or interrupting it

Steering and Lane Control Assistant: Assisted Driving Mode



General

 The button is used to switch the set function on and off.

 The button is used to set the primary function.

Setting the function



 When the system is active, press the button repeatedly until the desired function is selected in the toolbar. The Assisted Driving Mode toolbar is shown at the bottom of the instrument cluster.

Icon	Function
	Cruise Control with distance control.
	Cruise Control with distance control and Steering and Lane Control Assistant.

The selected function is shown in green.

Turning on the system

With Steering and Lane Control Assistant:

1.  Press the button on the steering wheel.
2.  Set Cruise Control if necessary.

Without Steering and Lane Control Assistant:

 Press the button on the steering wheel.

The indicator lights are illuminated in the instrument cluster and the marker in the speedometer is positioned at the current speed.

Cruise Control is active. The driven speed is maintained and stored as the set speed.

If necessary, the Dynamic Stability Control will be turned on.

Switching the system off

When switching off with the vehicle at a standstill, depress the brake at the same time.

Press the button on the steering wheel:

 With Steering and Lane Control Assistant.

 Without Steering and Lane Control Assistant.

The displays turn off. The stored set speed is deleted.

Manually interrupting the system

With the system active, press the button on the steering wheel:

 With Steering and Lane Control Assistant.

 Without Steering and Lane Control Assistant.

If interrupting the system when the vehicle is at a standstill, depress the brake at the same time.

Interrupting the system automatically

The system is interrupted automatically in the following situations:

- ▶ The driver brakes.
- ▶ Selector lever position D is disengaged.
- ▶ Dynamic Traction Control is activated or Dynamic Stability Control is deactivated.
- ▶ The Dynamic Stability Control adjusts.
- ▶ When the vehicle is stationary, the seat belt is unfastened and the driver's door is opened.
- ▶ The system has not detected any objects for an extended period, for example, on a road with very little traffic without curb or shoulder markings.
- ▶ The detection range of the radar is impaired, for example, by contamination or heavy precipitation.
- ▶ After an extended stationary period, if the vehicle was decelerated to a standstill by the system.

Setting the speed

Maintaining and saving the speed

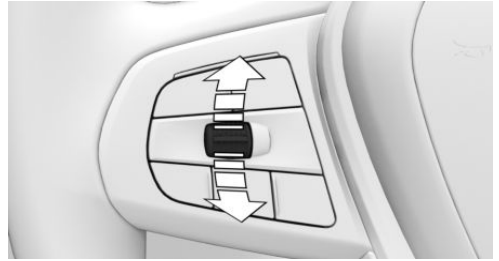

While the system is interrupted, press the rocker switch up or down once. The system is activated.

The current speed is maintained and stored as the set speed.

The stored speed is displayed on the speedometer.

If necessary, the Dynamic Stability Control will be turned on.

The speed can also be stored by pressing the button.

 Press the button.

Changing the speed

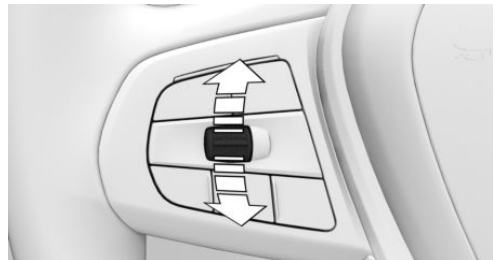

Press the rocker switch repeatedly up or down until the set speed is set.

If the system is active, the displayed speed is stored and the vehicle adjusts to the stored speed when the road is clear.

- ▶ Each time the rocker switch is tapped to the resistance point, the set speed is increased or decreased by 1 km/h, 1 mph.
- ▶ Each time the rocker switch is pressed beyond the resistance point, the set speed changes to the next multiple of 10 km/h on the km/h display or the next multiple of 5 mph on the mph display in the speedometer.

To repeat an action, hold the rocker switch in the relevant position.

Adjusting the distance

Safety note

WARNING

The system does not relieve you of your personal responsibility. System limitations may mean that braking is performed too late. There is a risk of accident or material damage. Pay close attention to the traffic conditions at all times. Adapt the distance to suit traffic and weather conditions and comply with the prescribed safe distance by braking if necessary.

Reducing the distance



Press the button repeatedly until the desired distance is set.

The selected distance is displayed in the instrument cluster.

Increasing the distance



Press the button repeatedly until the desired distance is set.

The selected distance is displayed in the instrument cluster.

Adapting the distance automatically

Depending on the equipment and national-market version: the system can be configured so that the distance to the vehicle in front is adapted au-

tomatically within the set distance according to the traffic situation or environmental factors, for example, poor visibility.

1. "MENU"
2. "Vehicle apps"
3. "Driving settings"
4. "Driver assistance"
5. "Driving"
6. "Speed Assistant"
7. "Adjust distance based on conditions"

Resuming Cruise Control

If Cruise Control is interrupted, it can be resumed by calling up the stored speed.

Before calling up the stored speed, make sure that the difference between the current speed and the stored speed is not too great. Otherwise, there may be unintentional deceleration or acceleration.

With the system interrupted, press the button on the steering wheel:



With Steering and Lane Control Assistant.



Without Steering and Lane Control Assistant.

Cruise Control is resumed with the stored values.

In the following instances, the stored speed value is deleted and therefore cannot be called up again:

- ▶ When the system is switched off.
- ▶ When drive-ready state is switched off.

Switching between Cruise Control with/without distance control

Safety note

WARNING

The system does not respond to traffic traveling in front of you, but instead maintains the stored speed. There is a risk of accident or material damage. Adjust the desired speed to the traffic conditions and brake if necessary.

Switching the Cruise Control mode

To switch Cruise Control without distance control on and off:

- ▶  Press and hold the button.

- ▶  Press and hold the button.

With Steering and Lane Control Assistant: to switch on distance control:

- ▶  Press the button.

Without Steering and Lane Control Assistant: to switch on distance control:

- ▶  Press the button.

- ▶  Press the button.

A Check Control message is then displayed.

Displays in the instrument cluster

General

Depending on the equipment, the displays in the instrument cluster may vary.

Display in the speedometer



Depending on the equipment, a mark in the speedometer displays the status of the system.





- ▶ Green marker: system is active, the marker shows the set speed.
- ▶ Grey marker: system is interrupted; the marker shows the stored speed.
- ▶ No marker: system is switched off.

Indicator and warning lights

Depending on the equipment:

Icon	Description
	White vehicle icon: No display of distance control because the accelerator pedal is being pressed.
	Green icon: Vehicle ahead detected. The vehicle icon goes out if no vehicle in front is detected. Vehicle icon flashes green: Preceding vehicle has driven off.
	Grey icon: System interrupted.

Icon	Description
	<p>Icon flashes grey:</p> <p>The requirements for system operation are no longer being met.</p> <p>The system has been deactivated but will continue to brake until you actively take over by depressing the brake or accelerator pedal.</p>
	<p>Vehicle icon flashes red and an acoustic signal sounds:</p> <p>Brake and take avoidance manoeuvre if necessary.</p>

Displays in the Head-up display

Set speed

Some information from the system can also be shown in the Head-up display.



The icon is displayed when the selected set speed has been reached.

Distance information



The icon is shown if your vehicle is too close to the vehicle ahead.

The distance information is active under the following circumstances:

- ▶ Active Cruise Control with Distance control is switched off.
- ▶ Display in the Head-up display selected. Head-up display, see page 174.
- ▶ Distance too close.
- ▶ Speed above approximately 70 km/h, 40 mph.

With Steering and Lane Control Assistant: prevent overtaking

This function helps to prevent inadvertent overtaking on motorways.

Depending on the equipment and the national-market version, the system can be configured to prevent overtaking in the slower driving lane.

The setting applies to speeds over 80 km/h/50 mph.

When the set speed is significantly higher than the speed in the adjacent lane, passing or overtaking may still be possible even if the function is switched on.

At speeds below 80 km/h/50 mph, vehicles on motorways are only overtaken with an adjusted differential speed.

The driver can overtake or accelerate at any time by pressing the accelerator pedal.

Turning the function on/off:

1. "MENU"
2. "Vehicle apps"
3. "Driving settings"
4. "Driver assistance"
5. "Driving"
6. "Speed Assistant"
7. ▶ "Avoid overtaking on the left"
 - ▶ "Avoid overtaking on the right"

System limits

System limits of the sensors

For further information:

- ▶ Cameras, see page 47.
- ▶ Radar sensors, see page 48.

Detection range

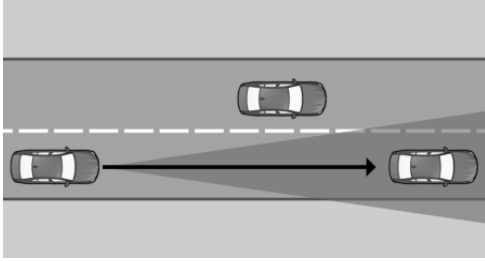

The system's detection capability and automatic braking capacity are limited.

For example, two-wheel vehicles may not be detected.

Deceleration

The system does not decelerate in the following situations:

- ▷ For pedestrians or similarly slow road users.
- ▷ Depending on the equipment and national-market version at red traffic lights.
- ▷ For crossing traffic.
- ▷ For oncoming vehicles.

Vehicles cutting in

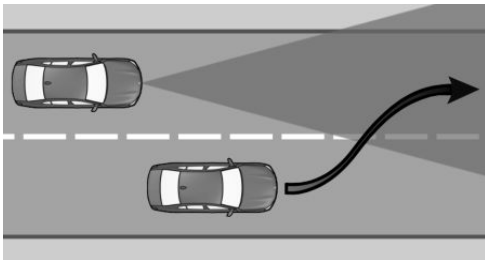

If another vehicle suddenly cuts in front of you, the system might not be able to restore the selected distance automatically. In some circumstances, it may also not be possible to restore the selected distance if you are driving significantly faster than vehicles in front, for example when rapidly approaching a lorry. If a vehicle is clearly detected in front of you, the system

prompts you to intervene by braking, and if necessary by taking avoidance manoeuvre.

Cornering

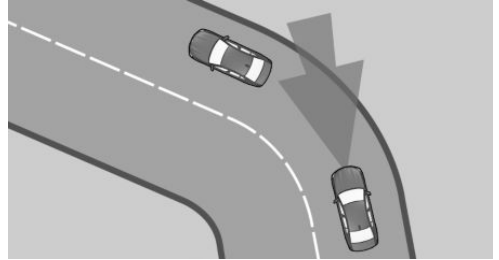

If the set speed is too high for cornering, it will be reduced slightly in the bend. However, since bends may not be anticipated in advance, moderate your speed when cornering.

The system has a restricted detection range. Situations can arise on tight bends where a vehicle driving in front will not be detected or will be detected very late.

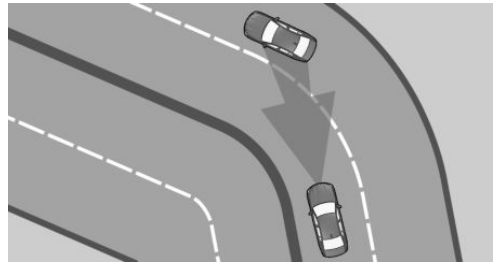

When your vehicle is approaching a bend, the curvature may cause the system to respond temporarily to vehicles in the other lane. If the system responds by decelerating the vehicle, you may compensate for this by accelerating briefly. When the accelerator pedal is released again, the system will resume control of the vehicle's speed.

Driving off

The vehicle cannot drive off automatically in some situations, for example:

- ▶ On steep upward gradients.
- ▶ Before bumps or rises in the road.
- ▶ When towing a heavy trailer.

In such cases, press the accelerator pedal.

Weather

In adverse weather and lighting conditions, system functionality may be limited as follows:

- ▶ Impaired detection of vehicles.
- ▶ Brief interruptions when vehicles have already been detected.

Pay attention when driving and respond to the prevailing traffic situation. If necessary, intervene actively, for example by braking, steering or taking avoidance manoeuvre.

Drive power

The set speed is also maintained when driving downhill. The vehicle may not achieve the set speed on uphill gradients if there is not enough drive power.

In ECO PRO drive mode, it is possible that the vehicle will drive faster or slower than the set speed setting in some situations, for example on downhill or uphill gradients.

Speed Limit Assist

Principle

Speed Limit Assist helps the driver to observe speed limits. A suggested speed can be adopted.

General

When the systems in the vehicle, for example Speed Limit Info, detect a change in the speed limit, it is possible to adopt this new speed value for the following systems:

- ▶ Manual Speed Limiter.
- ▶ Cruise Control.
- ▶ Active Cruise Control with distance control.

The speed value is proposed as a new set speed for adopting. The relevant system must be activated for the speed value to be adopted.

Depending on the equipment, destination system and national-market version, the value may be applied automatically.

With traffic light detection: Speed Limit Assist controls the speed when the vehicle approaches red traffic lights.

Safety notes

WARNING

The system does not relieve you of your personal responsibility to assess the traffic situation correctly. Due to system limitations, it cannot respond independently and appropriately in all traffic conditions. There is a risk of accident. Adapt your driving style to the traffic conditions. Observe the traffic situation and intervene actively if the situation warrants it.

WARNING

The desired speed may be set incorrectly by mistake or called up accidentally. There is a risk of accident. Adjust the desired speed to the traffic conditions. Observe the traffic situation and intervene actively if the situation warrants it.

Overview

Buttons on the steering wheel



Button	Function
	To accept the suggested speed manually. With traffic light detection: detected traffic lights are accepted manually.
	Rocker switch: To set the speed; see Cruise Control.

Turning Speed Limit Assist on/off

1. "MENU"
2. "Vehicle apps"
3. "Driving settings"
4. "Driver assistance"
5. "Driving"
6. "Speed Assistant"
7. "Speed limits"
8. Select the desired setting:
 - ▶ "Adjust automatically": depending on the equipment: detected speed limits are applied automatically.
With traffic light detection: detected traffic lights are accepted automatically if possible.
 - ▶ "Adjust manually": detected speed limits can be applied manually.
With traffic light detection: detected traffic lights can be accepted manually.
 - ▶ "Show anticipation": current and upcoming speed limits are displayed in the instrument cluster without being applied.
 - ▶ "Show current limit": current speed limits are displayed without being applied in the instrument cluster.
 - ▶ "Off": depending on the national-market version, Speed Limit Info and Speed Limit Assist will be turned off.
Other proactive comfort functions – the Route-ahead Assistant, for example – may be switched off.

Displays in the instrument cluster

A message is displayed in the instrument cluster when the system and a driver assistance system are activated.

Icon	Function
	Depending on the equipment, the indicator light illuminates green, together with the icon for a Cruise Control System: Speed Limit Assist is active and detected speed limits can be adopted manually for the displayed system.
	Detected change in speed limit detected with immediate effect. Distance information shown alongside the icon indicates there might be a change in the speed limit up ahead.
	Indicator light is illuminated green: the detected speed limit can be adopted with the SET button. With traffic light detection: detected traffic lights can be accepted with the SET button. A green tick is displayed once it has been adopted.

Automatic adoption

Depending on the equipment, a detected speed limit in automatic mode is automatically accepted for the Active Cruise Control with distance control or the Manual Speed Limiter.

	After an automatic adoption, the button can be pressed to switch back to the last set value of the set speed.
---	---

With traffic light detection: detected traffic lights are accepted automatically if possible.

Manual adoption

A detected speed limit can be applied manually for the active driver assistance system.

With traffic light detection: detected traffic lights can be accepted manually.

SET

When the SET icon is illuminated, press the button.

Speed adjustment

Principle

It is possible to set whether the speed limit will be accepted exactly, or with a tolerance.

General

A speed adaptation for all speed limits and an additional speed adaptation for speed limits up to 60 km/h/40 mph can be set up.

The additional speed adjustment for speeds up to 60 km/h/40 mph can be activated or deactivated.

Setting the speed adjustment

1. "MENU"
2. "Vehicle apps"
3. "Driving settings"
4. "Driver assistance"
5. "Driving"
6. "Speed Assistant"
7. Select the desired setting:
 - ▷ "Adjust speed limits": to set a speed adjustment tolerance that will affect all speeds.
 - ▷ "2nd adjustment up to": to activate or deactivate additional speed adjustment.
 - ▷ "Adjust speed limits": with activated additional speed adjustment, set the tolerance for speed limits up to 60 km/h/40 mph.

Adjusting to the route

Principle

Depending on the equipment, the system can be set so that the vehicle adapts the speed automatically to the route.

For example, the speed is reduced in the following situations if necessary:

- ▷ Before turning off.
- ▷ Before a roundabout.
- ▷ Before a bend.

Adjusting

1. "MENU"
2. "Vehicle apps"
3. "Driving settings"
4. "Driver assistance"
5. "Driving"
6. "Speed Assistant"
7. "Adjust to route" or "Automatically adjust speed to route"

Depending on the equipment version: traffic light detection

Principle

Speed Limit Assist controls the speed when the vehicle approaches red traffic lights.

General

The camera near the interior mirror is used to detect red traffic lights.

If necessary, the system also uses the Driver Attention Camera and the information that has been saved in the navigation system.

Detected red traffic lights are displayed in the instrument cluster and, depending on the setting, can be taken into account by Speed Limit Assist either manually or automatically during the journey.

Overview

Sensors

The system is controlled using the following sensors:

- ▶ Cameras behind the windscreen.

For further information:

Sensors in the vehicle, see page 47.

Operating requirements

- ▶ Active Cruise Control with distance control is activated.
- ▶ Speed up to approx. 80 km/h, 50 mph.
- ▶ The function must be available in the country in which the vehicle is being driven.



Activating/deactivating

1. "MENU"
2. "Vehicle apps"
3. "Driving settings"
4. "Driver assistance"
5. "Driving"
6. "Speed Assistant"
7. "Consider traffic lights"

Drive off reminder

1. "MENU"
2. "Vehicle apps"
3. "Driving settings"
4. "Driver assistance"
5. "Driving"
6. "Speed Assistant"
7. "Drive off reminder": when the vehicle is stopped at traffic lights, the detected phase of the lights can be displayed in the instrument cluster. In addition, there will be visual and acoustic information as soon as driving can continue at a green traffic light.

Displays in the instrument cluster

Icon	Meaning
	Red traffic light detected. As soon as a green tick is displayed after adoption, the vehicle brakes to a standstill.
	Green traffic light detected.
	Green traffic light: the system is interrupted. If the grey traffic light is displayed with a red cross, it cannot be offered for acceptance.

System limits

Speed Limit Assist is based on the Speed Limit Info system.

Take into account the Speed Limit Info system limits.

Depending on the national-market version, upcoming speed limits may not be available for application or they may only be available to a certain extent, for instance speed information from the navigation system.

Cruise Control without distance control: depending on the system, it may not be possible to adopt speed limits automatically.

Upcoming speed limits can only be applied to Active Cruise Control with distance control.

Depending on the equipment and national-market version, the system may not respond at all or with limitations to the route when the navigation system is unable to clearly identify the position of the vehicle.

The traffic light detection system may have restricted functionality in situations such as the following:

- ▷ Traffic lights are obscured, for example by other vehicles.
- ▷ At a road junction with multiple lanes where there are several sets of traffic lights.

For further information:

- ▷ Limits of the Speed Limit Information system, see page 170.
- ▷ System limits of the sensors, see page 47.

Steering and Lane Control Assistant

Principle

The Steering and Lane Control Assistant helps to keep the vehicle in driving lane. It does this by performing supporting steering wheel movements, for example when cornering.

General

Depending on the speed, the system orientates itself using the lane markings and vehicles driving in front.

Sensors on the steering wheel detect whether the steering wheel is being touched.



Safety note

WARNING

The system does not relieve you of your personal responsibility to assess the traffic situation correctly. Due to system limitations, it cannot respond independently and appropriately in all traffic conditions. There is a risk of accident. Adapt your driving style to the traffic conditions. Observe the traffic situation and intervene actively if the situation warrants it.

Overview

Buttons on the steering wheel

Button	Function
	Steering and Lane Control Assistant with traffic jam assistant on/off.
	To set the function.

Sensors

The system is controlled using the following sensors:

- ▷ Cameras behind the windscreen.
- ▷ Front radar sensor.
- ▷ Side radar sensors, front.
- ▷ Side radar sensors, rear.

For further information:

Sensors in the vehicle, see page 47.

Operating requirements

- ▷ Speed under 210 km/h/130 mph.
- ▷ The lane width is sufficiently wide.
- ▷ Above 70 km/h, 43 mph: lane demarcations are detected on both sides.
- ▷ Below 70 km/h, 43 mph: lane markings on both sides or a vehicle driving in front is/are detected.
- ▷ Hands on the steering wheel rim.
- ▷ Sufficient corner radius.
- ▷ Driving in the centre of the driving lane.
- ▷ Turn indicator switched off.
- ▷ The sensor system calibration process is complete.
- ▷ Cruise Control with distance control active.
- ▷ Seat belt on the driver's side fastened.
- ▷ Collision Warning active.

- ▶ Pedestrian warning active.
- ▶ Side collision warning active.

Switching the Steering and Lane Control Assistant on/off

Assisted Driving Mode

General



The button is used to switch the set function on and off.





The button is used to set the primary function.

Setting the function





When the system is active, press the button repeatedly until the desired function is selected in the toolbar. The Assisted Driving Mode toolbar is shown at the bottom of the instrument cluster.

Icon	Function
	Cruise Control with distance control.
	Cruise Control with distance control and Steering and Lane Control Assistant.

The selected function is shown in green.

Turning on the system

1.  Press the button on the steering wheel.
 2.  Adjust the Steering and Lane Control Assistant if necessary.
-  Steering wheel icon illuminates grey.

System is on standby and does not make any steering wheel movement.

The system activates automatically when all operating requirements are met.



Steering wheel icon illuminates green.

The system is active.

When the system is switched on, the Pedestrian Warning with city braking function and the side-collision warning are active.

Switching the system off



Press the button on the steering wheel.

The display is no longer illuminated.

The system does not perform any supporting steering wheel movements.

Automatically interrupting Steering and Lane Control Assistant

The system interrupts the supporting steering movements automatically, for example in the following situations:

- ▶ At a speed above 210 km/h/130 mph.
- ▶ When the steering wheel is released.
- ▶ The driver brakes.
- ▶ When the steering wheel is turned sharply.
- ▶ When the vehicle leaves its own driving lane.
- ▶ When the turn indicator is activated.
- ▶ When the driving lane is too narrow.
- ▶ If a lane boundary is not detected for a certain period of time and no vehicle is driving in front.
- ▶ Active Cruise Control with distance control is interrupted.
- ▶ The seat belt on the driver's side is unfastened.









Steering wheel icon illuminates grey.

System is on standby and does not make any steering wheel movement.

The system activates automatically when all operating requirements are met.

Displays in the instrument cluster

Icon	Description
	Steering wheel icon grey: System on standby.
	Steering wheel icon green: System is activated. The system is helping the driver keep the vehicle in driving lane.
	Yellow flashing steering wheel icon: Lane marking driven over. The steering wheel vibrates where applicable.
	Yellow steering wheel icon and an acoustic signal, if applicable: System interruption is imminent.
	Steering wheel icon flashes red, signal sounds: System is switching off.

Icon	Description
	Steering wheel icon yellow: Hands are not around the steering wheel. System remains active.
	Red steering wheel icon, acoustic signal: Hands are not around the steering wheel. System interruption is imminent. The system reduces the speed to a standstill if applicable. The system may possibly not perform any supporting steering wheel movements.

Displays on the steering wheel



The two LEDs above the keypads are illuminated in the same way as the displays in the instrument cluster:

- ▶ Yellow: system interruption is imminent.
- ▶ Red: system is deactivated.

The steering wheel displays can be switched on/off if required.

1. "MENU"
2. "Vehicle apps"
3. "Driving settings"
4. "Driver assistance"
5. "Feedback via steering wheel"
6. "Lighting elements"

Displays in the Head-up display

All the system information can also be displayed in the Head-up display.

System limits

General

The system cannot be activated or used usefully in certain situations.

Safety note

WARNING

The system may not respond at all, or may respond too late, incorrectly or without justification due to system limitations. There is a risk of accident or material damage. Observe the information on the system limits and intervene actively if necessary.

System limits of the sensors

For further information:

- ▶ Cameras, see page 47.
- ▶ Radar sensors, see page 48.

Hands on the steering wheel

In the following situations, contact between the driver's hands and the steering wheel is not detected by the sensors:

- ▶ Driving when wearing gloves.
- ▶ Covers on the steering wheel.

Narrow driving lanes

The system cannot be activated or used usefully when driving in narrow driving lanes, for example in the following situations:

- ▶ At road works.
- ▶ Depending on the equipment, if emergency lanes are being formed.
- ▶ In built-up areas.

Weather

In adverse weather and lighting conditions, system functionality may be limited as follows:

- ▶ Impaired detection of vehicles and lane markings.
- ▶ Brief interruptions when vehicles have already been detected.

Pay attention when driving and respond to the prevailing traffic situation. If necessary, intervene actively, for example by braking, steering or taking avoidance manoeuvre.

Assisted Driving Plus

Principle

Assisted Driving Plus helps the driver to control the vehicle in traffic queues.

The supporting steering wheel movements take place without the driver actively steering.

General

The system uses the sensors of the Steering and Lane Control Assistant.

Safety note

WARNING

The system does not relieve you of your personal responsibility to assess the traffic situation correctly. Due to system limitations, it cannot respond independently and appropriately in all traffic conditions. There is a risk of accident. Adapt your driving style to the traffic conditions. Observe the traffic conditions, be ready to take over steering and braking at any time, and actively intervene if the situation warrants it.

The information for the Steering and Lane Control Assistant also applies.

For further information:

Steering and Lane Control Assistant, see page 241.

Operating requirements

- ▶ Operating requirements of the Steering and Lane Control Assistant are met.
 - Operating requirements, see page 241.
- ▶ The Steering and Lane Control Assistant is active.
- ▶ The function is only available on certain types of road, for example motorways.
- ▶ Driving on a road without pedestrians or cyclists.
- ▶ The lane width is sufficiently wide.
- ▶ Lane markings and a vehicle ahead are detected.
- ▶ Speed under approximately 60 km/h/40 mph.
- ▶ The Driver Attention Camera in the instrument cluster detects that the driver is looking at the traffic situation.
- ▶ The function must be available in the country in which the vehicle is being driven.

Turning Assisted Driving Plus on



As soon as all of the operating requirements have been met, Assisted Driving Plus is displayed as an additional icon in the toolbar. The toolbar is shown at the bottom of the instrument cluster.

ASSIST PLUS



Select Assisted Driving Plus with the button on the steering wheel.

The icon for Assisted Driving Plus is shown in green.

Two green LEDs are illuminated on the steering wheel.

The indicator light in the instrument cluster is shown in green.

The system starts to help the driver to control the vehicle.

Displays in the instrument cluster

Icon	Description
	Green indicator light: the system is active.
	White indicator light: the system is ready.
	Grey indicator light: the system is interrupted.

Alternative displays

Depending on the equipment, the displays in the instrument cluster may vary and are shown as follows:

Indicator light	Description
	Green indicator light: the system is active.

Displays on the steering wheel



The two LEDs above the keypads are illuminated in the same way as the displays in the instrument cluster:

- ▶ Green: the system is active.
- ▶ Yellow: the system has been interrupted.
- ▶ Red: the system is deactivated.

System limits

General

The system limits for the Steering and Lane Control Assistant apply.

For further information:

Steering and Lane Control Assistant, see page 241.

Driver Attention Camera

Pay attention to the traffic situation at all times.

The Driver Attention Camera detects whether the driver is looking at the traffic situation.

The Driver Attention Camera may have restricted functionality in situations such as the following:

- ▶ If the Driver Attention Camera is covered by the steering wheel.
- ▶ If the driver is wearing sunglasses with high protection against infrared light.

Lane Change Assistant

Principle

Lane Change Assistant provides the driver with additional support when changing driving lanes on multi-lane roads.

General

The system uses the sensors of the Steering and Lane Control Assistant.

Safety note

WARNING

The system does not relieve you of your personal responsibility to assess the traffic situation correctly. Due to system limitations, it cannot respond independently and appropriately in all traffic conditions. There is a risk of accident. Adapt your driving style to the traffic conditions.

Observe the traffic situation and intervene actively if the situation warrants it.

The information for the Steering and Lane Control Assistant also applies.

For further information:

Steering and Lane Control Assistant, see page 241.

Operating requirements

- ▶ Operating requirements of the Steering and Lane Control Assistant are met.
 - Operating requirements, see page 241.
- ▶ Driving on a road without pedestrians or cyclists and with physical barriers separating oncoming vehicles, for example crash barriers.
- ▶ Lane markings detected.
- ▶ Maximum speed 180 km/h, 110 mph.
- ▶ The minimum speed is country-specific.

Turning on/turning off Lane Change Assistant

1. "MENU"
2. "Vehicle apps"
3. "Driving settings"
4. "Driver assistance"
5. "Driving"
6. "Assisted Driving"
7. "Lane Change Assistant"

Changing driving lane

1. Ensure that the traffic situation permits a lane change.
2. Press the turn indicator lever in the desired direction as far as the resistance point for indicating briefly.

After a short period, a supporting steering wheel movement in the desired direction is noticeable.

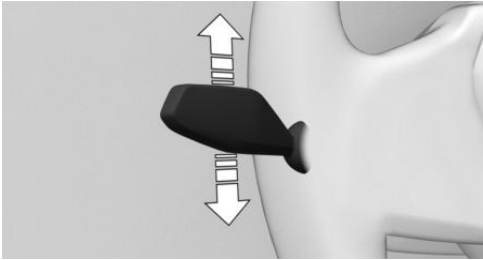



After the lane change, the system helps the driver keep the vehicle in lane.

Cancelling a lane change



The lane change can be cancelled by steering in the opposite direction.

Displays in the instrument cluster

Icon	Description
	<p>Green steering wheel icon.</p> <p>Green arrow icon for lane change.</p> <p>The system carries out a lane change.</p>
	<p>Green steering wheel icon.</p> <p>Grey line for lane marking on the appropriate side.</p> <p>The system has detected the lane change request. Lane change not currently possible.</p>
	<p>Depending on the national-market version:</p> <p>Green steering wheel icon.</p> <p>Grey arrow icon for lane change.</p> <p>Lane change not possible; operating requirements not met.</p>

Alternative displays

Depending on the equipment, the displays in the instrument cluster may vary and are shown as follows:

Icon	Description
	<p>Green steering wheel icon.</p> <p>Grey line for lane marking on the appropriate side.</p> <p>Green arrow icon for lane change.</p> <p>The system carries out a lane change.</p>
	<p>Green steering wheel icon.</p> <p>Grey line for lane marking on the appropriate side.</p> <p>No arrow icon for lane change on the display.</p> <p>The system has detected the lane change request. Lane change not currently possible.</p>
	<p>Depending on the national-market version:</p> <p>Green steering wheel icon.</p> <p>Grey line for lane marking on the appropriate side.</p> <p>Grey arrow icon for lane change.</p> <p>Lane change not possible; operating requirements not met.</p>

System limits

The system limits for the Steering and Lane Control Assistant apply.

For further information:

Steering and Lane Control Assistant, see page 241.

Emergency Lane Assistant

Principle

The Emergency Lane Assistant can help the driver to form an emergency lane on congested motorways or similar roads.

As soon as the system detects a traffic queue, a Check Control message is shown on the control display. Depending on the situation, the vehicle will be steered to the right or left within the current driving lane in order to form an emergency lane.

General

The system uses the sensors of the Steering and Lane Control Assistant.

Safety note

WARNING

The system does not relieve you of your personal responsibility to assess the traffic situation correctly. Due to system limitations, it cannot respond independently and appropriately in all traffic conditions. There is a risk of accident. Adapt your driving style to the traffic conditions. Observe the traffic situation and intervene actively if the situation warrants it.

The information for the Steering and Lane Control Assistant also applies.

For further information:

Steering and Lane Control Assistant, see page [241](#).

Operating requirements

- ▶ Steering and Lane Control Assistant is activated.
- ▶ Traffic queue detected.
- ▶ Driving on a motorway or a similar road.

- ▶ Lane boundary detected.
- ▶ The function must be available in the country in which the vehicle is being driven.

Activating/deactivating the Emergency Lane Assistant

1. "MENU"
2. "Vehicle apps"
3. "Driving settings"
4. "Driver assistance"
5. "Driving"
6. "Assisted Driving"
7. "Emergency Corridor Assistant"

Displays in the instrument cluster

Depending on the equipment and national-market version, the information of the Emergency Lane Assistant is displayed in the Assisted View in the instrument cluster.

For further information:

Assisted View, see page [154](#).

System limits

The system limits for the Steering and Lane Control Assistant apply.

For further information:

Steering and Lane Control Assistant, see page [241](#).

Lane change with active route guidance

Principle

Lane change with active route guidance assists the driver when a lane change is needed in order to reach a destination.

General

The system uses the sensors of the Steering and Lane Control Assistant.

Safety note

WARNING

The system does not relieve you of your personal responsibility to assess the traffic situation correctly. Due to system limitations, it cannot respond independently and appropriately in all traffic conditions. There is a risk of accident. Adapt your driving style to the traffic conditions. Observe the traffic situation and intervene actively if the situation warrants it.

The information for the Active Cruise Control and the Steering and Lane Control Assistant also applies.

For further information:

- ▶ Active Cruise Control, see page 229.
- ▶ Steering and Lane Control Assistant, see page 241.

Operating requirements

- ▶ Active Cruise Control with distance control is activated.
- ▶ Driving on a motorway or a similar road.
- ▶ A lane boundary is detected on the side of the desired lane change.
- ▶ Navigation system: route guidance is activated.
- ▶ The adjustment to route is turned on.
- ▶ The function must be available in the country in which the vehicle is being driven.

Changing driving lane

1. One or more lane changes are required in order to reach a destination.

The system prepares for this lane change. To do this, the system identifies a suitable gap in the flow of traffic in the adjacent lane.

2. When a gap has been found, the speed is adapted so the vehicle stays level with the gap.
3. A lane change suggestion is displayed with a Check Control message.

When the Steering and Lane Control Assistant is active, a steering intervention to steer the vehicle towards the target driving lane may be performed.

4. If the traffic situation permits a lane change, the driver can steer the vehicle into the adjacent lane.

If the vehicle is equipped with the Lane Change Assistant: once the Check Control message has been displayed, the Lane Change Assistant can be started by operating the turn indicator.

Display in the instrument cluster

Icon	Function
	The proposed lane change is displayed and a green tick indicates that the function is active.

Depending on the equipment and national-market version, the traffic situation is displayed in the Assisted View in the instrument cluster.

For further information:

Assisted View, see page 154.

Switching on adjustment to route

1. "MENU"
2. "Vehicle apps"
3. "Driving settings"
4. "Driver assistance"
5. "Driving"

6. "Speed Assistant"
7. "Adjust to route" or "Automatically adjust speed to route"

System limits

The system limits for the Active Cruise Control and the Steering and Lane Control Assistant apply.

Parking

Vehicle equipment

This chapter describes equipment, systems and functions which are offered or will be offered on a model-specific basis, even if they are not included in the vehicle in question.

For further information:

Vehicle equipment, see page 7.

Park assistance systems

General

The parking assistance systems include different individual systems. The individual systems provide support with assistance functions, sensors and different camera views when parking, manoeuvring or driving in reverse.

For further information:

- ▶ Reversing Assist Camera, see page 255.
- ▶ Automatic camera perspective, see page 255.
- ▶ Flank view, see page 256.
- ▶ 3D view, see page 256.
- ▶ Zoom to trailer tow hitch, see page 257.
- ▶ Washing bay view, see page 257.
- ▶ Panorama View, see page 257.
- ▶ Door opening angle, see page 259.
- ▶ Remote 3D View, see page 259.
- ▶ Park Distance Control, see page 260.
- ▶ Active Park Distance Control, see page 263.
- ▶ Park Assist, see page 264.
- ▶ Reversing Assistant, see page 269.

Overview

Button in the vehicle

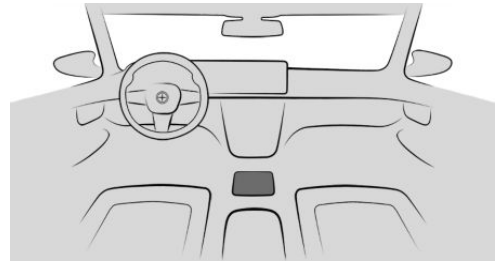

Park Assist button



Panorama View

Sensors

The parking assistance systems are controlled by the following sensors:

- ▶ Ultrasonic sensors in the front/rear bumpers.
- ▶ Side ultrasonic sensors.
- ▶ Side radar sensors, front.
- ▶ Side radar sensors, rear.
- ▶ Front camera.
- ▶ Exterior mirror cameras.
- ▶ Reversing Assist Camera.

For further information:

Sensors in the vehicle, see page 47.

Safety note

WARNING

The system does not relieve you of your personal responsibility to assess the traffic situation correctly. Due to system limits, it cannot respond independently and appropriately in all traffic situations. There is a risk of accident. Adapt your driving style to the traffic conditions. In addition, look directly to check the traffic situation and the vehicle surroundings and intervene actively where appropriate.

Go to Park menu

Some parking assistance systems can be adjusted in the Park menu.

Via Parking Assistant button



1. Press the button.
2. "Settings"
3. Select the desired settings.

Via iDrive

1. "MENU"
2. "Vehicle apps"
3. "Driving settings"
4. "Driver assistance"
5. "Parking and manoeuvring"
6. Select the desired settings.

Display

Principle

The parking assistance systems display assists with parking and manoeuvring by displaying the Park Distance Control and a variety of camera perspectives.

General

Several cameras capture the area from various selectable perspectives.

Depending on the view, the vehicle surroundings or a partial area are displayed.

Depending on the national-market version, the automatic camera perspective or the Reversing Assist Camera is displayed.

Turning the display on/off

General

When driving forwards, the parking assistance systems display turns off automatically when a certain distance or speed is exceeded.

With the reverse gear

The display is automatically turned on if selector lever position R is engaged while drive-ready state is turned on.

Via Parking Assistant button



Press the button.

Display on the control display

General

The display on the control display will vary depending on the equipment and the activated parking assistance system.

Without Parking Assistant Plus

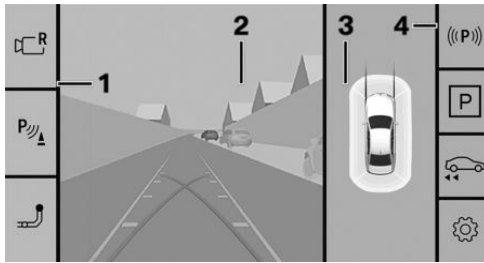

- 1 Toolbar, left
- 2 Camera image
- 3 Selection window
- 4 Toolbar, right

The Park Distance Control view is displayed.

- ▷ "Parking"
Depending on the equipment, camera images or the view of the Park Distance Control are displayed.
- ▷ "3D view"
A three-dimensional representation is displayed.
- ▷ "Tow hitch"
The zoom for the trailer tow hitch can be turned on.
- ▷ "Car wash"
The display of your own lane can be turned on for easier driving into the car wash.

With Parking Assistant Plus

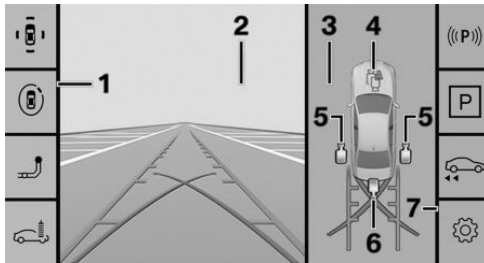

- 1 Toolbar, left
- 2 Camera image
- 3 Selection window
- 4 Automatic camera perspective
- 5 Flank view
- 6 Reversing Assist Camera
- 7 Toolbar, right

Toolbar, right

The parking assistance functions are displayed in the right toolbar. The display may vary depending on the equipment.

- ▷ Status and functions of Park Assist.
- ▷ Status and functions of Reversing Assistant.
- ▷ "Settings"
Settings can be entered in the Park menu.

Status of the parking assistance systems

The status of the following parking assistance systems is displayed:



- ▷ Park Assist.
- ▷ Reversing Assistant.

The icons are shown on the control display in the right toolbar.

Toolbar, left

Depending on the equipment, different views can be selected via the left toolbar.

- ▷ "Rear view camera"
The camera image from the Reversing Assist Camera is shown.
- ▷ "Parking sensors only"

Icon	Meaning
	No search for Park Assist services. Park Assist has failed.
	Search for Park Assist services is active.
	Park Assist: when the icon is green, Park Assist is active. The system takes control of the vehicle. Reversing Assistant: when the icon is green, Reversing Assistant is active. The system takes control of the steering.

Additional displays

General

Additional displays can be faded in on the camera image of the parking assistance systems display to facilitate parking and manoeuvring.

Turning additional displays on/off

Depending on the equipment, the additional displays can be turned on and off in the parking menu or in the right toolbar.

Driving lane lines

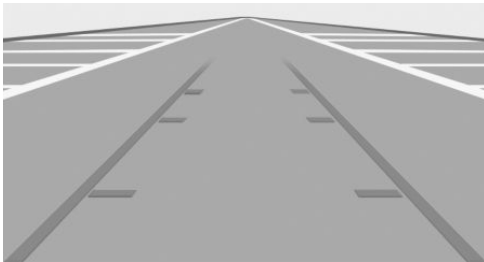

Driving lane line help estimate the space required when parking and manoeuvring on level roads.

The driving lane lines are continuously adapted to the steering wheel movements depending on the steering wheel angle.

Turning circle lines

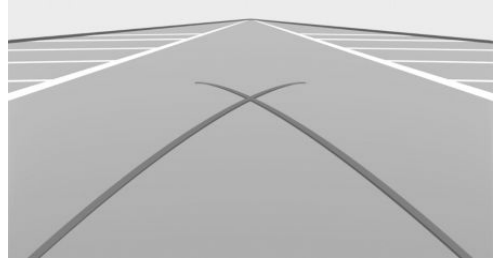

Turning circle lines can only be superimposed on the camera image together with lanes.

The lines show the course of the smallest possible turning circle on a level road.

Once the steering wheel has been turned beyond a certain angle, only one turning circle line is displayed.

Using driving lane lines and turning circle lines

1. Position the vehicle so that the red turning circle line is within the boundaries of the parking space.
2. Turn the steering wheel so that the green driving lane line covers the corresponding turning circle line.

Obstacle marking

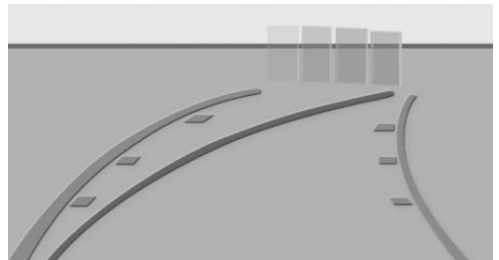

Obstacles are detected by the sensors.

Obstacle markings can be faded into the camera image.

Coloured gradations of the obstacle markings in green, yellow and red indicate the distances.

Functional limitations

The system can only be used to a restricted extent in the following situations:

- ▷ With a door open.
- ▷ With open luggage compartment.
- ▷ With the exterior mirrors folded in.

Areas with grey hatching with an icon in the camera image identify areas that are currently not shown, for example an open door.

System limits

Safety note

WARNING

The system may not respond at all, or may respond too late, incorrectly or without justification due to system limitations. There is a risk of accident or material damage. Observe the information on the system limits and intervene actively if necessary.

System limits of the sensors

For further information:

Sensors in the vehicle, see page 47.

Non-visible areas

Due to the angle of view, the area under the vehicle cannot be seen by the cameras.

Detection of objects

The system cannot detect very low obstacles and higher, protruding objects such as ledges.

The objects shown in the control display may be closer than they appear. Do not estimate the distance to the objects on the control display.

Projecting loads, carrier systems or trailers can restrict the detection range of the camera.

Malfunction

Failure of one camera is shown on the control display.

The detection range of the failed camera is displayed hatched on the control display.

Reversing Assist Camera

Principle

The Reversing Assist Camera assists in reverse parking and manoeuvring. It does this by showing an image of the area behind the vehicle on the control display.

Additional displays can be shown in the display, for example lane and turning circle lines.

General

Follow the information in the Chapter "Parking assistance systems".

Operating requirements

- ▷ The luggage compartment is fully closed.
- ▷ The camera area is clean and unobstructed.

Deactivated Reversing Assist Camera

When the Reversing Assist Camera is deactivated, for example when the luggage compartment is open, the camera image is displayed hatched in grey.

Automatic camera perspective

Principle

The automatic camera perspective displays a steering angle-dependent view looking towards the vehicle's direction of travel.

This perspective adapts to the current driving situation.

General

As soon as obstacles are detected, the view switches to a fixed display of the area in front of or behind the bumper or, if necessary, to the Lateral Parking Aid page.

When reverse gear is engaged, the automatic camera perspective is exited if necessary and the view of the Reversing Assist Camera is displayed. If required, select the automatic camera perspective with reverse gear engaged. The automatic camera perspective is retained for the current parking manoeuvre.

Follow the information in the Chapter “Parking assistance systems”.

Lateral Parking Aid

Principle

The side Park Distance Control is automatically displayed and warns of obstacles next to the vehicle.

General

Follow the information in the Chapter “Parking assistance systems”.

Display



Obstacle markings are displayed at the sides of the vehicle to protect the vehicle's flanks.

- ▶ No markings: no obstacles have been detected.
- ▶ Coloured markings: warning that obstacles have been detected.

System limits

The system only shows stationary obstacles that were previously detected by the sensors when driving past.

The system does not detect whether an obstacle subsequently moves. Consequently, the markings will no longer be shown on the display after the vehicle has been stationary for a while. The area next to the vehicle needs to be scanned again.

Flank view

Principle

The flank view displays the area at the side to assist with positioning the vehicle at the kerb or alongside any other obstacles.

General

Flank view looks from the rear to the front. If there is a hazard, it automatically focuses on possible obstacles.

Flank view can be selected for the right or left side of vehicle.

Follow the information in the Chapter “Parking assistance systems”.

3D view

Principle

When the 3D view is selected, a circle is displayed on the control display.

Specified perspectives can be selected on the circle.

General

The current perspective is identified by a camera icon.

Select another camera function to exit the function.

Follow the information in the Chapter "Parking assistance systems".

Zoom to trailer tow hitch

Principle

To assist with connecting up a trailer, it is possible to zoom in on the area around the trailer tow hitch.

General

When zooming in, remember that the view might no longer show certain obstacles.

Follow the information in the Chapter "Parking assistance systems".

Turning zoom on trailer tow hitch on/off



1. Press the button.
2. "Tow hitch"

Display

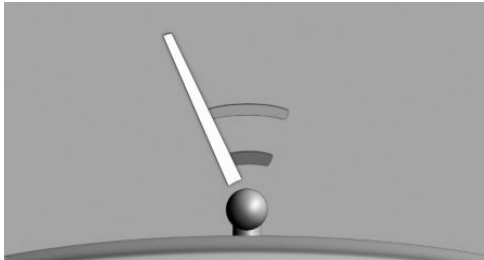

Two static circle segments show the distance between the trailer and the trailer tow hitch.

A docking line dependent on the steering wheel angle assists you in lining up the trailer tow hitch with the trailer.

Washing bay view

Principle

The washing bay view assists when entering a car wash.

General

Follow the information in the Chapter "Parking assistance systems".

Turning the car wash view on/off



1. Press the button.
2. "Car wash"

Display

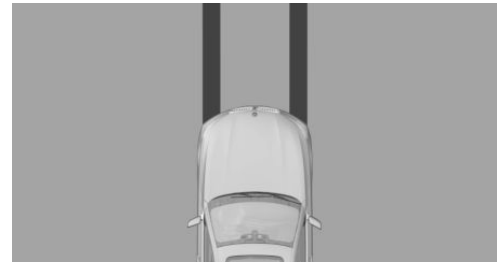

Your own lane is displayed for easier driving into a car wash.

Panorama View

Principle

The panoramic view gives you an earlier view of crossing traffic at blind driveway exits and road junctions.

General

Road users hidden by obstacles at the side may not be seen from the driver's seat until very late. The front camera and the Reversing Assist Cam-

era capture the area around the side of the vehicle to improve the view.

The camera image is subject to varying levels of distortion in some areas and is thus not suitable for estimating distances.

Depending on the equipment, the function can be used when driving forwards or reversing.

Follow the information in the Chapter "Parking assistance systems".

Sensors

The system is controlled by the following cameras:

- ▷ Reversing Assist Camera.
- ▷ Front camera.

Turning the panoramic view on/off



Press the button.

Display



Yellow lines on the screen mask identify the bumpers of your own vehicle.

Depending on the engaged selector lever position, the camera image of the Reversing Assist Camera or front camera will be displayed.

Activation points

Principle

Positions at which the panoramic view should switch on automatically can be saved as activation points.

General

Up to ten activation points can be saved.

Activation points can be used for the front camera when driving forwards.

Operating requirements

To use the function, a GPS signal must be received.

Saving activation points

1. Drive the vehicle to the position where the system should turn on and stop.



2. Press the button.

3. "Activation point"

The current position is shown.

4. "Save activation point"

Activation points are stored with one of the following where possible:

- ▷ Location.
- ▷ Town and street.
- ▷ GPS coordinates.

Using activation points

Use of activation points can be switched on and off.



1. Press the button.
2. "Settings"
3. "GPS-based"

Displaying activation points



1. Press the button.
2. "Manage points"
A list of all activation points is shown.

Editing activation points



1. Press the button.
2. "Manage points"
A list of all activation points is shown.
3. Select an activation point if necessary.
4. Select the desired setting.

Door opening angle

Principle

Depending on the equipment, the door opening angle indicator is displayed automatically.

If obstacle marking is activated, the parking view indicates fixed obstacles that obstruct the opening angles of the doors.

The system does not issue warnings about approaching road users.

General

Follow the information in the Chapter "Parking assistance systems".

Display

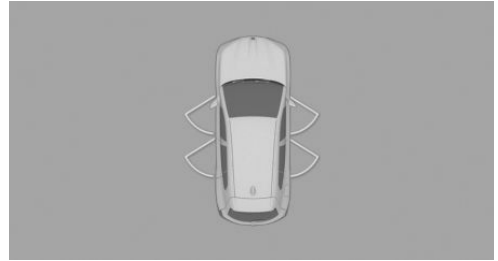

The maximum door opening angles are displayed when the selector lever is in position P.

System limits

For technical reasons, the display of the vehicle surroundings is distorted.

Even if the door opening angle indicator on the control display does not superimpose any other objects, it is necessary to park carefully next to other objects.

The perspective means that protruding objects located higher up may be closer than they appear on the control display.

Remote 3D View

Principle

The BMW app and the camera pictures in the parking view, for example automatic camera perspective, enable the display of the vehicle surroundings on a mobile end device.

The function shows a view of the current situation.

General

For reasons related to data protection, the function can only be run three times in two hours.

Follow the information in the Chapter "Parking assistance systems".

Sensors

The system is controlled by the following cameras:

- ▷ Front camera.
- ▷ Exterior mirror cameras.
- ▷ Reversing Assist Camera.

Operating requirements

- ▷ Data transfer must be activated.
Data protection, see page 70.
- ▷ The BMW app must be installed on the mobile device.
- ▷ ConnectedDrive countries: a BMW ID with an existing ConnectedDrive account must be activated.
BMW ID/driver profiles, see page 71.

Activating/deactivating Remote 3D View

The function can be activated or deactivated individually or together with other functions.

1. "MENU"
2. "Vehicle apps"
3. "System settings"
4. "Data privacy"
5. Select the desired setting.

After the activation, Remote 3D View can be accessed in the BMW app.

Functional limitations

The system may have restricted functionality or may not be available at all in situations such as the following:

- ▷ With a door or the luggage compartment open. Areas that the system is not able to record are shown dark on the display.
- ▷ If the exterior mirrors have been folded in manually.

- ▷ When other camera functions are being run in the vehicle.
- ▷ The vehicle moves faster than at walking speed.
- ▷ In case of missing or weak Internet connection.

Park Distance Control

Principle

Park Distance Control assists with parking. Obstacles in front of or behind the vehicle are signalled by acoustic and visual warnings.

Obstacles that are detected by the side ultrasonic sensors can also be reported.

General

The range of the system is approximately 2 m, 6 ft, depending on the obstacle and environmental factors.

An acoustic warning is given when the vehicle is approx. 70 cm, 27 in away from an object and a collision is imminent.

For objects behind the vehicle, the acoustic warning is given sooner, at a distance of approx. 1.50 m, 5 ft.

Follow the information in the Chapter "Parking assistance systems".

Safety notes

WARNING

The system does not relieve you of your personal responsibility to assess the traffic situation correctly. Due to system limits, it cannot respond independently and appropriately in all traffic situations. There is a risk of accident. Adapt your driving style to the traffic conditions. In addition, look directly to check the traffic situation and the vehicle surroundings and intervene actively where appropriate.

⚠ WARNING

Approaching at high speed when using Park Distance Control PDC may result in late warnings, due to the physical conditions. There is a risk of injury or material damage. Avoid approaching an object at speed. Avoid moving off at speed while Park Distance Control PDC is not yet active.

Sensors

The system is controlled using the following sensors:

- ▶ Ultrasonic sensors in the front/rear bumpers.
- ▶ Side ultrasonic sensors.

Turning Park Distance Control on/off

Turning on the system automatically

The system switches on automatically in the following situations:

- ▶ When the drive-ready state is turned on when engaging selector lever position R.
- ▶ When approaching detected obstacles, if the speed is below approximately 4 km/h, 2.5 mph. The distance from the obstacle at which the system activates depends on the individual situation.

Automatic activation on detection of obstacles can be enabled and disabled.

1. "MENU"
2. "Vehicle apps"
3. "Driving settings"
4. "Driver assistance"
5. "Parking and manoeuvring"
6. "Automatic PDC activation"

Turning off the system automatically

When driving forwards, the system turns off automatically when a certain distance or speed is exceeded, if necessary.

Turning the system on/off manually



Press the button.

- ▶ On: the LED is illuminated.
- ▶ Off: the LED is extinguished.

If the system is manually turned on when reverse gear is engaged, the image of the Reversing Assist Camera is displayed.

Depending on the national-market version, the system cannot be turned off manually when the reverse gear is engaged.

Acoustic warning

General

An intermittent tone indicates that the vehicle is approaching an object. For example, if an object is detected to the rear left of the vehicle, the acoustic signal is emitted from the rear left loudspeaker.

The shorter the distance to an object, the shorter the intervals of the intermittent tones.

A continuous tone sounds if the distance to a detected object is less than approximately 20 cm, 8 in.

An alternating continuous tone sounds between the front and rear loudspeakers if there are objects in front and behind the vehicle at the same time and at a distance of less than approximately 20 cm, 8 in.

The intermittent tones and the continuous tone are turned off when selector lever position P is engaged.

Depending on the national-market version, the interval tones are switched off after a short time with the vehicle at a standstill.

Adjusting the volume

The volume of the acoustic warning can be adjusted.

1. "MENU"
2. "Vehicle apps"

3. "Driving settings"
4. "Driver assistance"
5. "Parking and manoeuvring"
6. "PDC signal volume"
7. Set the desired value.

Visual warning

General

When you are approaching an object, its proximity is displayed on the control display as soon as the system is activated.

Objects that are farther away are already displayed before a signal sounds.

The detection range of the sensors is shown in green, yellow and red if obstacles are detected within the range.

Depending on the view, driving lane lines, turning circle lines and obstacle markings are shown for a better estimation of the space required.

If equipped with the Crossing-traffic Warning: depending on the equipment, the display also warns of vehicles approaching from the sides at the front and rear.

Obstacle markings are displayed at the sides of the vehicle to protect the vehicle's flanks.

Display: object behind the vehicle

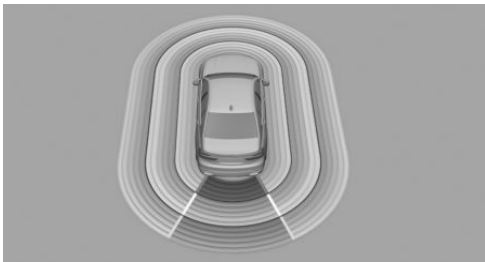

Display: object next to the vehicle

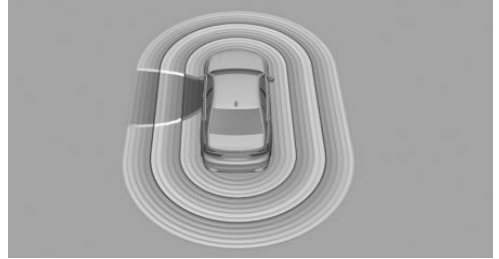

Depending on the equipment:

- ▶ Grey markings, hatched surface: no obstacles have been detected.
- ▶ No markings, black surface: the area adjacent to the vehicle has not yet been detected.

System limits

General

The function to protect the vehicle sides only shows stationary obstacles that were previously detected by the sensors when driving past.

The system does not detect whether an obstacle subsequently moves. With the vehicle at a standstill, the side markings will be hidden after a certain period of time. The area on the side of the vehicle must be newly captured.

Also observe the limits of the system in the chapter "Parking assistance systems".

Trailer operation

The rear functions of Park Distance Control are turned off if a trailer is connected, when the trailer socket is occupied or when trailer operation is activated.

Obstacles next to the vehicle are not displayed.



An icon is displayed on the control display.

Depending on the equipment, the detection range of the sensors is shown dark on the control display.

False alarms

If the system is approaching its limits, false alarms may occur.

To reduce false alarms, for example in conveyor car washes, switch off automatic activation of Park Distance Control when obstacles are detected if necessary.

Malfunction



An icon is displayed on the control display.

The detection range of the sensors is not displayed on the control display.

A Check Control message is shown.

Park Distance Control failure. Have the system checked by a Service Partner of the manufacturer or another qualified Service Partner or a specialist workshop.

Active Park Distance Control

Principle

The Park Distance Control brake function initiates emergency braking if there is an imminent risk of collision.

General

Due to the system limits, a collision cannot be prevented under all circumstances.

The function is available at speeds below walking speed when reversing or rolling back.

Pressing the accelerator pedal suppresses the brake intervention. No emergency braking is performed.

After emergency braking to a stop, it is possible to continue a slow approach to the obstacle. To approach, lightly depress the accelerator pedal and release it again.

If the accelerator pedal is depressed for longer, the vehicle pulls away. Manual braking is possible at any time.

Follow the information in the Chapter "Parking assistance systems".

Safety notes

WARNING

The system does not relieve you of your personal responsibility to assess the traffic situation correctly. Due to system limits, it cannot respond independently and appropriately in all traffic situations. There is a risk of accident. Adapt your driving style to the traffic conditions. In addition, look directly to check the traffic situation and the vehicle surroundings and intervene actively where appropriate.

WARNING

When the trailer tow hitch is in use, the assistance system cannot react correctly if its sensors are obstructed. There is a risk of accident or material damage. Do not use the assistance system in trailer operation or when using the trailer tow hitch, for example with a bicycle carrier.

Sensors

The system is controlled using the following sensors:

- ▶ Ultrasonic sensors in the front/rear bumpers.
- ▶ Side ultrasonic sensors.

Temporarily turning off Active Park Distance Control

After emergency braking, the function can be temporarily turned off on the control display.

1. "Obstacle detected. Emergency braking."
2. "Deactivate temporarily"

If the journey is continued in these environmental conditions, no further emergency braking is performed.

The system will be turned on again automatically for the next drive.

Settings

It is possible to set which areas of the vehicle are protected by the system.

1. "MENU"
2. "Vehicle apps"
3. "Driving settings"
4. "Driver assistance"
5. "Parking and manoeuvring"
6. "Active PDC emergency braking"
7. Select the desired setting.

Display



As soon as the system detects an obstacle, an icon is displayed with a corresponding message.

System limits

The system cannot be used in situations such as the following:

- ▷ When driving with a trailer.

If applicable, turn off the system temporarily, if needed.

Also observe the limits of the system in the chapter "Parking assistance systems".

Park Assist

Principle

Park Assist supports driving into parallel and bay parking spaces and helps driving out of parallel parking spaces.

Vehicle equipment

This system may not be available in the vehicle in question, for example due to the selected optional equipment, the national-market version or

the possibility of subsequent enabling and software updates. This also applies to the individual functions of the system.

For further information:

Vehicle equipment, see page 7.

General

Follow the information in the Chapter "Parking assistance systems".

Parking methods

The system supports the following functions:

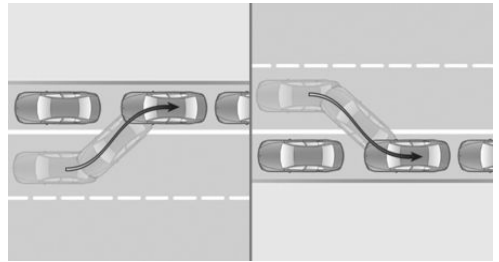

Reverse parking parallel to the road, parallel parking.

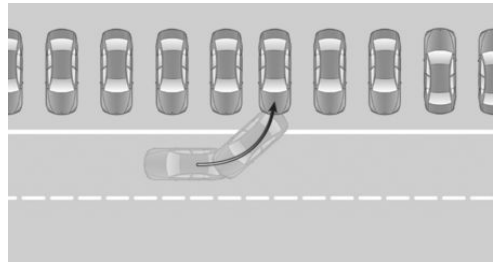

Reverse parking transverse to the road, bay parking.

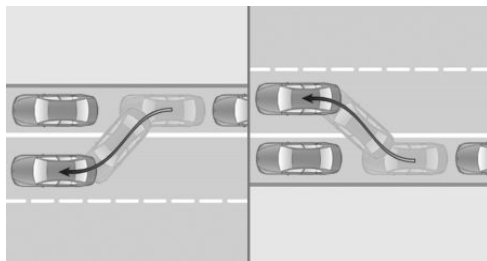

Leaving parallel parking spaces.

Operation

The operating principle and operation of the system is divided into the following steps:

- ▶ Parking space search.
- ▶ Turn on.
- ▶ Parking.
- ▶ Leaving parking space.

Parking space search is always active when the vehicle is moving forward slow and straight.

Ultrasonic sensors measure parking spaces on both sides of the vehicle.

When the system is active, the status of the system and necessary instructions are displayed.

Parking manoeuvre

The system calculates the best possible option for driving in or driving out of parking spaces with parking lines and takes control of the following functions during the parking manoeuvre:

- ▶ Steering.
- ▶ Accelerating and braking.
- ▶ Changing gear.

The parking manoeuvre is automatic.

When leaving parallel parking spaces, the vehicle manoeuvres automatically until the vehicle reaches a position in which the driver can drive out of the parking space without further steering wheel movements.

Safety notes

WARNING

The system does not relieve you of your personal responsibility to assess the traffic situation correctly. Due to system limits, it cannot respond independently and appropriately in all traffic situations. There is a risk of accident. Adapt your driving style to the traffic conditions. In addition, look directly to check the traffic situation and the vehicle surroundings and intervene actively where appropriate.

WARNING

When the trailer tow hitch is in use, the assistance system cannot react correctly if its sensors are obstructed. There is a risk of accident or material damage. Do not use the assistance system in trailer operation or when using the trailer tow hitch, for example with a bicycle carrier.

NOTE

The system can steer the vehicle over or onto kerbs. There is a risk of material damage. Observe the traffic situation and intervene actively if the situation warrants it.

Sensors

The Parking Manoeuvre Assistant is controlled by the following sensors:

- ▶ Ultrasonic sensors in the front/rear bumpers.
- ▶ Side ultrasonic sensors.

Operating requirements

Measurement of parking spaces

- ▶ Driving forwards in a straight line up to a maximum speed of approximately 35 km/h, 22 mph.
- ▶ Maximum distance from the row of parked vehicles: 1.5 m, 5 ft.

Suitable parking space

General:

- ▶ Gap behind an object which is at least 0.5 m, 1.7 ft long.
- ▶ Gap between two objects, each at least 0.5 m, 1.7 ft long.
- ▶ Minimum length of adjoining objects approx. 1 m/3 ft.

Parking parallel to the road:

- ▶ Minimum length of gap between two objects: own vehicle length plus approximately 0.8 m, 2.6 ft.
- ▶ Minimum depth: approximately 1.5 m, 5 ft.

Bay parking:

- ▶ Minimum width of gap: own vehicle width plus approximately 0.7 m, 2.3 ft.
- ▶ Minimum depth: own vehicle length.
The depth of bay parking spaces must be estimated by the driver. Due to technical limits, the system is only able to gauge the depth of bay parking spaces approximately.

Parking manoeuvre

- ▶ Doors and luggage compartment are closed.
- ▶ Driver's seat belt is fastened.

Leaving parking space

- ▶ The vehicle was parked using the Parking Manoeuvre Assistant and an object is detected in the surrounding area of the vehicle.
- ▶ The vehicle was parked manually in reverse and objects in the immediate vicinity of the

vehicle are detected. The distance to a detected kerb is at least 15 cm, approx. 6 in.

- ▶ The parking space is at least 0.8 m, 2.6 ft longer than the vehicle.

Turning Park Assist on/off

Via Parking Assistant button



Press the button.

The current status of the parking space search is displayed.

With the reverse gear

Engage selector lever position R.

The current status of the parking space search is displayed.

Turning the acoustic signal on/off

The acoustic signal for suitable parking spaces can be turned on and off.

1. "MENU"
2. "Vehicle apps"
3. "Driving settings"
4. "Driver assistance"
5. "Parking and manoeuvring"
6. "Sound when available"

Acoustic signal of the Park Distance Control



Depending on the national-market version, an intermittent tone of the Park Distance Control PDC will sound during an automatic parking manoeuvre.

A continuous tone will sound when the distance to a detected object is less than approx. 20 cm, 8 in.



Parking space search

- ▶ Parking space search is always active when driving forwards at a speed of up to approx. 35 km/h, approx. 22 mph and a distance of max. 1.5 m, approx. 5 ft for vehicles to be parked.
- ▶ ((P)) Park Assist is turned on and the parking space search is activated. Search for suitable parking spaces.
- ▶ Suitable parking spaces are displayed and an acoustic signal sounds.
- ▶ When parallel or bay parking spaces are clearly detected, the system automatically selects the appropriate parking method. If there are parking spaces that are large enough for both parallel and bay parking, both parking spaces are shown on the control display. The parking direction can be selected by selecting the parking space.

Parking with Park Assist

1. Press the  key or engage reverse gear.
The display of the parking assistance systems is shown.
((P)) Parking space search is activated.
The status of the parking space search and possible parking spaces are shown on the control display.
2. Select the suggested parking manoeuvre.
 Green: the system takes control of the parking manoeuvre.
3. Follow the instructions on the control display.
The speed can be reduced with the brake. Other interventions will cancel the system.
When parking manoeuvre is complete, selector lever position P is engaged.
Completion of parking manoeuvre is indicated on the control display.
4. Adjust the parking position yourself if necessary.

Leaving parking space with Park Assist

1. Switch on drive-ready state.
2.  With the vehicle at a standstill, press the button or engage reverse gear.
The display of the parking assistance systems is shown.
3. Select the desired parking direction for leaving the parking space on the control display.
4. Follow the instructions on the control display.
 Green: the system takes control of the parking manoeuvre.
The speed can be reduced with the brake. Other interventions will cancel the system.
A message is displayed at the end of the manoeuvre.
5. Make sure that it is safe to leave parking space in the current traffic situation and drive off as usual.
The Parking Manoeuvre Assistant is turned off automatically.

Cancelling Park Assist manually

Park Assist can be cancelled manually at any time, for example:

- ▶  Press the button.
- ▶ by depressing the accelerator pedal.
The Parking Manoeuvre Assistant is cancelled without engaging selector lever position P. Driving can continue immediately.

Cancelling Park Assist automatically

The system automatically cancels in situations such as the following:

- ▷ If the driver grips the steering wheel or steers the vehicle.
- ▷ When the accelerator pedal is pressed lightly and the steering wheel is simultaneously moved gently.
- ▷ When operating the accelerator pedal or the selector lever.
- ▷ When the brake pedal is depressed longer at a vehicle standstill.
- ▷ If the parking brake is applied.
- ▷ When the driver's seat belt is unfastened.
- ▷ With open luggage compartment.
- ▷ With open bonnet.
- ▷ When the doors are open.
- ▷ During activation or intervention by driver assistance systems.
- ▷ If you switch to other functions on the control display.
- ▷ When the display on the control display is faded due to messages.
- ▷ On snow-covered or slippery road.
- ▷ On steep uphill or downhill gradients.
- ▷ If it encounters objects that are difficult to negotiate, for example kerbs.
- ▷ If objects appear suddenly.
- ▷ With insufficient distances, which are indicated by the Park Distance Control.
- ▷ When a maximum number of parking moves or the parking time is exceeded.

A Check Control message is shown where applicable.

Continuing the parking manoeuvre

If parking or leaving a parking space has been interrupted, the operation can be continued, if needed.

To do this, switch Park Assist on again and follow the instructions on the control display.

System limits

General

Observe the limits of the system in the Chapter "Park assistance systems".

No parking assistance

Park Assist does not provide assistance in the following situations:

- ▷ On sharp bends.
- ▷ In angled parking spaces.
- ▷ In trailer operation.
- ▷ With parking spaces which are marked by lines on the floor only. The system orients itself on objects.
- ▷ For special parking spaces, for example pay parking spaces with automatic locking mechanisms, coin parking or mechanical parking systems.

Functional limitations

The system may have restricted functionality in situations such as the following:

- ▷ On uneven road surfaces, for example gravel roads.
- ▷ On slippery surfaces.
- ▷ On steep uphill or downhill gradients.
- ▷ If leaves have collected or snow has drifted or been piled up in the parking space.
- ▷ If an already measured parking space changes.
- ▷ If there are ditches or sudden drops, for example a quayside.
- ▷ In some cases, parking spaces may be detected that are not suitable or suitable parking spaces may not be detected.

Malfunction

A Check Control message is shown.

Park Assist has failed. Have the system checked by a Service Partner of the manufacturer or an-

other qualified Service Partner or a specialist workshop.

Reversing Assistant

Principle

The Reversing Assistant assists when driving in reverse, for example when driving out of tight or confusing parking or street situations.

Vehicle equipment

This system may not be available in the vehicle in question, for example due to the selected optional equipment, the national-market version or the possibility of subsequent enabling and software updates. This also applies to the individual functions of the system.

For further information:

Vehicle equipment, see page 7.

General

The vehicle saves the driving movements for the last distance covered. This stored distance can be driven back with automated steering.

The system takes control of the steering. The speed must be controlled by the driver using the accelerator pedal and the brake.

A maximum of 50 m, approx. 164 ft are stored.

Follow the information in the Chapter "Parking assistance systems".

Safety notes

WARNING

The system does not relieve you of your personal responsibility to assess the traffic situation correctly. Due to system limits, it cannot respond independently and appropriately in all traffic situations. There is a risk of accident. Adapt your driving style to the traffic conditions. In addition, look directly to check the traffic sit-

uation and the vehicle surroundings and intervene actively where appropriate.

WARNING

When the trailer tow hitch is in use, the assistance system cannot react correctly if its sensors are obstructed. There is a risk of accident or material damage. Do not use the assistance system in trailer operation or when using the trailer tow hitch, for example with a bicycle carrier.

NOTE

The system can steer the vehicle over or onto kerbs. There is a risk of material damage. Observe the traffic situation and intervene actively if the situation warrants it.

Operating requirements

- ▶ To save the distance covered, drive forwards without interruption.
- ▶ To store the distance covered, do not drive faster than 35 km/h/22 mph.
- ▶ No trailer operation.
- ▶ Dynamic Stability Control is activated.

Reversing with automated steering

1. Switch on drive-ready state.



2.  With the vehicle at a standstill, press the button or engage reverse gear.

The display of the parking assistance systems is shown.

3.  "Reversing Assistant"
Follow the instructions on the control display as applicable.
4. Take your hands off the steering wheel and carefully drive in reverse with the accelerator pedal and the brake.

 Green: the system takes control of the steering.

When driving in reverse, observe the vehicle surroundings.

In case of obstacles, stop immediately and take over control of the vehicle. Pay attention to the information on Park Distance Control.

5. Right before the end of the stored distance covered, an acoustic signal will sound and a message is displayed.

Stop when you reach normal road traffic at the latest and take over control of the vehicle, for example by engaging a forward gear.

Cancelling the Reversing Assistant automatically

The system automatically cancels in situations such as the following:

- ▷ If the driver grips the steering wheel or steers the vehicle.
- ▷ When shifting from reverse gear to another selector lever position.
- ▷ During activation or intervention by driver assistance systems.
- ▷ After an extended period of time when the vehicle is stationary.
- ▷ When exiting the stored lane when reversing, for example with a maximum steering wheel angle.
- ▷ When the display on the control display is faded due to messages.
- ▷ In case of a slippery surface.
- ▷ When the vehicle is rolling, for example on a slope.
- ▷ In case of changed environmental factors.
- ▷ When the trailer socket is occupied or trailer operation is activated.
- ▷ At speeds over approximately 9 km/h, approx. 6 mph.

System limits

- ▷ The maximum speed when driving in reverse is limited to approx. 9 km/h, approx. 6 mph.

A warning occurs at a speed of approx. 7 km/h/4 mph.

If the maximum speed is exceeded, the function will be cancelled.

- ▷ After driving a stored distance with major steering-wheel angles, the function of the system will be restricted for the return trip.

Various factors can cause the vehicle to deviate sideways when reversing along the saved distance covered. These factors include, for example:

- ▷ If the steering wheel is moved with the vehicle stationary while the distance covered is being saved.
- ▷ The speed is not adapted to the distance covered in question.
- ▷ Road characteristics, for examples gradients, inclines or slippery road surface.
- ▷ Greatly deviating conditions when storing and driving the distance covered, for example, different tyres or changed environmental factors like the weather.

Also observe the limits of the system in the chapter "Parking assistance systems".

Driving comfort

Vehicle equipment

This chapter describes equipment, systems and functions which are offered or will be offered on a model-specific basis, even if they are not included in the vehicle in question.

For further information:

Vehicle equipment, see page 7.

Suspension components

The suspension components have been optimised for the vehicle and its area of use, thus ensuring the best possible driving experience.

Self-levelling suspension

Principle

The air suspension on the rear axle helps the self-levelling suspension to ensure that the vehicle height and ground clearance remain constant. Irrespective of load, the system maintains the height of the vehicle at the rear axle at a specified level.

The system ensures consistent driving comfort, as the full spring travel is kept constant in all driving situations.

Malfunction

A Check Control message is shown. The system is faulty. There is a change in the vehicle's handling characteristics or a noticeable restriction in driving comfort. Visit the nearest Service Partner of the manufacturer or another qualified Service Partner or a specialist workshop.

Extended stationary periods

The vehicle may lower itself during extended stationary periods. This is not a malfunction.

If drive-ready state is switched on with the doors closed, the vehicle is automatically raised to the normal level.

Adaptive M suspension

Principle

The adaptive M suspension is an intelligent, controllable sport suspension.

The suspension reduces body movements with a sporty driving style or on an uneven road.

General

The intelligent control of the suspension increases the driving dynamics and driving comfort depending on the road condition and driving style.

Setting

The system offers various shock absorber settings, from comfortable travel to sporty driving.

The shock absorbers are adjusted depending on the selected drive mode as well as the road condition and driving style.

For further information:

Driving Experience Control, see page 144.

Performance Control

Performance Control increases the agility of the vehicle.

Individual wheels are braked to increase agility for a sporty driving style.

Electric motor sound

Depending on the equipment and national-market version, settings can be made for the drive sound.

1. "MENU"
2. "Vehicle apps"
3. "Driving settings"
4. "Drivetrain and chassis"
5. "IconicSounds"
6. Select the desired setting.

Air conditioning

Vehicle equipment

This chapter describes equipment, systems and functions which are offered or will be offered on a model-specific basis, even if they are not included in the vehicle in question.









For further information:



Vehicle equipment, see page 7.

Air conditioning control

Overview

Functions in the air conditioning menu



Icon	Function
	AUTO programme.
	Temperature.
	Maximum cooling.
	Air recirculation function.
	Automatic air recirculation control.
	Fresh air.
	Amount of air.
	Air distribution.

Icon	Function
	SYNC programme.
	Seat heating, see page 122.
	Active seat ventilation, see page 123.

The functions can also be operated via voice, for example, Temperature.

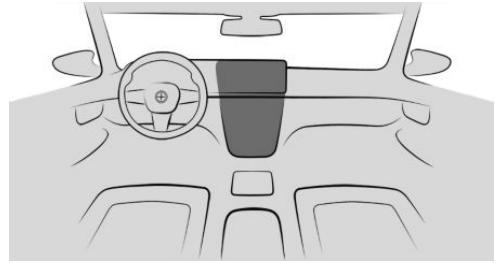
Buttons, integrated automatic heating/air conditioning system



Icon	Function
	Defrost function.
	Rear window heating.

Buttons, automatic rear air-conditioning system

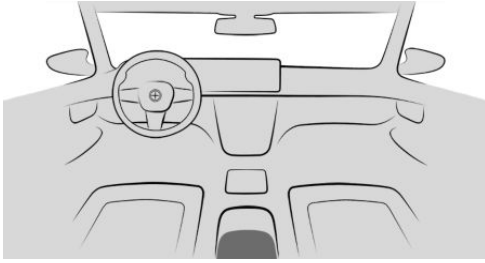

Icon	Function
	AUTO programme.
	Temperature.
	Air distribution.
	Seat heating, see page 122.
	To switch off.

- 4 Air conditioning functions, passenger's side
- 5 Air conditioning bar

Locking the rear air-conditioning operating elements

1. "CLIMATE MENU"
2. "Settings"
3. "Rear climate control"
4. "Lock rear climate control"

Air conditioning menu

General

In the Climate control menu, air conditioning functions can be set individually.

Depending on the equipment, the following air conditioning functions can be accessed via the Climate control menu, for example:

- ▷ AUTO programme.
- ▷ Amount of air.
- ▷ Air distribution.
- ▷ Seat heating.
- ▷ Active seat ventilation.

Display in the display

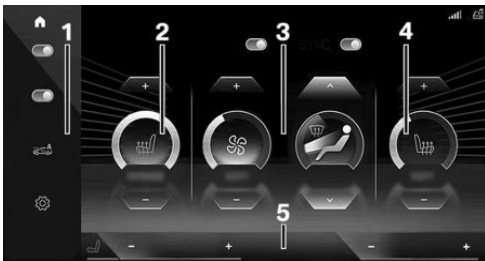

- 1 Toolbar
- 2 Air conditioning functions, driver's side
- 3 Air conditioning functions

Go to air conditioning functions

Via air conditioning bar:

"CLIMATE MENU" tap in the centre of the air conditioning bar.

or:

1. "MENU"
2. "Vehicle apps"
3. "Climate control"

Turning the air conditioning system on/off

Turning the air conditioning system on/off

1. "CLIMATE MENU"
2. "All climate functions"
3. Select the desired setting.

The complete air conditioning system is turned on/off with the last settings.

When the air conditioning system is turned on, individual air conditioning functions can be turned off.

Turning automatic rear air-conditioning system on/off

Operating requirements

- ▷ Automatic air conditioning is turned on.
- ▷ Defrost function is deactivated.

Turning the system on/off via iDrive

1. "CLIMATE MENU"
2. "Settings"
3. "Rear climate control"
4. Activate "Rear climate control".

The automatic rear air-conditioning system can be activated with the default setting for temperature and AUTO programme:

"Activate with default settings"

Turning on the system with the button

Press one of the following buttons:

- ▷ Temperature.
- ▷ AUTO programme.
- ▷ Air distribution, manual.

Turning off the system with the button

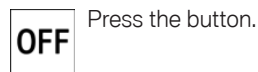

AUTO programme

Principle

The AUTO programme ensures a comfortable climate, which can be modified with the set temperature and individual settings.

The AUTO programme cools, ventilates or heats the interior automatically.

General

Depending on the equipment, the AUTO programme provides the best possible settings for air conditioning functions depending on the outside temperature, interior temperature, sunlight, seat occupancy and the desired temperature setting:

- ▷ Amount of air.
- ▷ Air distribution.
- ▷ Temperature.
- ▷ Seat heating.
- ▷ Active seat ventilation.

The AUTO programme is started automatically at each vehicle start.

The AUTO programme takes the seat occupancy into account to ensure energy-efficient control.

A condensation sensor also controls the programme so that window condensation is avoided as much as possible.

Turning the AUTO programme on/off

1. "CLIMATE MENU"
2. "Automatic programme"
3. Select the desired setting.

Automatic rear air-conditioning system:



Press the button.

The LED in the button is illuminated when the AUTO programme is switched

on.

Setting the intensity

When the AUTO programme is activated, the intensity of individual air conditioning functions can be individually adjusted.

Each air conditioning function has multiple levels that can be adjusted individually. Each level has a specific control range of the intensity.

Based on the stored data models, the intensities are dynamically adjusted during the journey. It is not necessary to manually change the desired intensity to lower or higher levels while driving.

Functional example

When the AUTO programme is turned on, the intensity of the seat heating can be adjusted:

1. "CLIMATE MENU" tap in the centre of the air conditioning bar.
2.  Seat heating.
3. Select the desired settings, for example, "HIGH".

The individually selected settings of the air conditioning functions are stored and automatically set up again, for example, after the vehicle is started again.

Display

The indicator in the climate control bar informs of the temperature differential between configured desired temperature and current interior temperature:

- ▶ The red or blue bar next to the temperature display indicates the progress of heating up or cooling.
- ▶ The desired interior temperature is reached as soon as the bar is no longer displayed.

Active air conditioning functions, for example, seat heating are displayed as icons in the climate control bar.

Active air conditioning functions are highlighted in colour in the climate control menu.

Temperature

Principle

The automatic air conditioning cools or heats to the set temperature and then keeps the temperature constant.

General



Avoid switching between different temperature settings in rapid succession. The automatic air conditioning may not have sufficient time to adjust to the set temperature.

Adjusting the temperature

The temperature can be set individually for driver and front passenger in the air conditioning bar.



Set the desired temperature:

- ▶  Increase the temperature.
- ▶  Reduce the temperature.

Setting the automatic rear air-conditioning system temperature

Using the button:



Press the left or right side of the button to set the desired temperature.

Via iDrive:

1. "CLIMATE MENU"
2. "Settings"
3. "Rear climate control"
4. Set the desired temperature.

Adjusting the upper body temperature

General

The air temperature in the upper body area can be adjusted.

The set interior temperature for driver and front passenger is not changed by this.

Adjusting the upper body temperature

1. "CLIMATE MENU"
2. "Settings"
3. "Temperature adjustment upper body"
4. Set the desired temperature.

Maximum cooling

Principle

The function enables quick and intense cooling of the interior.

General

The system is set to the lowest temperature, maximum amount of air and air recirculation function.

Operating requirements

The function is available at an outside temperature above approximately 0 °C/32 °F and when driving readiness or standby state is switched on.

Turning maximum cooling on/off

1. "CLIMATE MENU"
2. "MAX A/C"
3. Select the desired setting.

The air flows from the air vents for the upper body area. Open the vents.

Air recirculation function

Principle

If the air outside the vehicle has an unpleasant odour or contains pollutants, the supply of outside air into the interior of the vehicle can be shut off. The interior air is then recirculated.

General

If there is condensation, switch off the air recirculation function.

When the air recirculation function is turned off, outside air is directed into the interior.

In the automatic recirculated-air control, outside air is drawn in or the interior air is circulated, depending on the outside air quality.

The interior filter cleans the incoming outside air or the circulated inside air in air recirculation mode.

Turning the air recirculation function on/off

1. "CLIMATE MENU"
2. Select the desired setting in the toolbar:
 - ▷ "Air recirculation"
 - ▷ "Fresh air"
 - ▷ "Auto air recirculation"

The current operating mode is displayed in the toolbar.

Depending on the equipment, the air recirculation function will turn off automatically after some time depending on the environmental factors to prevent condensation.

Amount of air

General

The blower-generated air flow can be adjusted individually as needed.

Adjusting the amount of air

1. "CLIMATE MENU"
2.  Amount of air.

3. Select the desired setting.

The level of the selected amount of air is displayed.

The amount of air may be reduced in order to save the vehicle battery power.

Air distribution

General

The air distribution can be adjusted individually as needed.

Adjusting the air distribution

1. "CLIMATE MENU"
2.  Air distribution.
3. Select the desired setting.

The selected air distribution is displayed.

Automatic rear air-conditioning system:



Press the button repeatedly. Select the desired setting.

The selected air distribution setting is shown on the climate display.

SYNC programme

Principle

If the SYNC programme is activated, it can be used to transfer settings on the driver's side to the passenger's side and to the rear.

General

The following settings can be transferred:

- ▷ Temperature.
- ▷ Air distribution.
- ▷ AUTO programme.

Turning the SYNC programme on/off

1. "CLIMATE MENU"
2. "SYNC"

The programme is switched off automatically if settings are changed on the passenger's side or in the rear passenger compartment.

Defrost function

Principle

With the defrost function, ice and condensation are quickly removed from the windscreen and the front side windows.

General

The amount of air and air temperature are automatically optimised for the removal of ice and condensation.

The air distribution is directed toward the windscreen and the front side windows.

If there is condensation, turn on the AUTO programme to utilise the advantages of the condensation sensor. Ensure that air can flow towards the windscreen.

When the defrost function is switched on, the automatic rear air-conditioning system is deactivated to provide maximum power.

Turning the defrost function on/off



Press the button.

The LED in the button is illuminated when the system is switched on.

Rear window heating

Principle

With the rear window heating, ice and condensation are quickly removed from the rear window.

Operating requirements

The drive-ready or standby state is turned on.

Turning the rear window heating on/off



Press the button.

The LED is illuminated when the rear window heating is switched on.

The rear window heating switches off automatically after a while.

If pre-conditioning is turned on, the rear window heating is activated as needed.

Ventilation

Principle

The ventilation system provides individual ranges of adjustment for direct or indirect ventilation to optimise the movement of air inside the vehicle.

General

Open the air vents and position them in a way that ensures effective climate control.

The air flow heats or cools noticeably, depending on the set temperature.

Ventilation at front

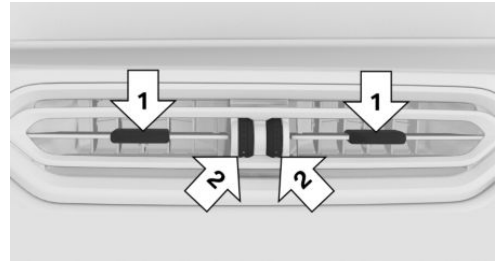

- ▷ Lever for changing the air flow direction, arrows 1.
- ▷ Knurled wheel for the variable adjustment of the air flow on the vents, arrows 2.

Ventilation in rear passenger compartment

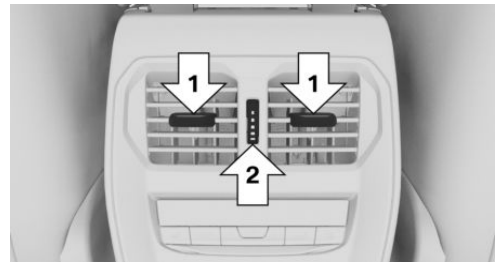

- ▷ Lever for changing the air flow direction, arrows 1.
- ▷ Knurled wheel for steplessly opening and closing the air vents, arrow 2.

Adjusting the ventilation

Depending on the set ventilation, align the air flow directly or indirectly toward the passengers.

Air quality

General

The air quality in the interior is improved by the following components:

- ▷ Emissions-tested interior.
- ▷ Interior filter.
- ▷ Climate control system for regulating temperature, amount of air and air recirculation function.
- ▷ Pre-conditioning.
- ▷ Automatic air recirculation control.

Interior filter

The interior filter cleans the incoming outside air or the circulated inside air in air recirculation mode.

Depending on the equipment:

- ▷ Dust and pollen are filtered out from the inflowing outside air.
- ▷ Nano-particle emissions are reduced.
- ▷ Gaseous pollutants are filtered.
- ▷ Microbial particles and allergens are filtered.

Pre-conditioning

Principle

Pre-conditioning cools or heats the vehicle interior to a comfortable temperature prior to starting the journey depending on the inside and outside temperature. Any snow and ice can be removed more easily.

General

The pre-conditioning can be switched on and off directly or for a preselected departure time.

Depending on the equipment, the following air conditioning functions are controlled automatically:

- ▷ Seat heating.
- ▷ Active seat ventilation.
- ▷ Steering wheel heating.
- ▷ Rear window heating.
- ▷ Mirror heating.

The air automatically flows out of the air vents to the windscreen, side windows, upper body area and the footwell.

The system shuts down automatically after approximately 30 minutes or by activating the drive-ready state.

Using the pre-conditioning while the vehicle is being charged will reduce the air conditioning capacity during the journey. This helps to optimise the range.

To ensure the vehicle can achieve a minimum range, the pre-conditioning may be switched off automatically, for example after switching on several times or due to the high-voltage battery being insufficiently charged. After turning off due to an insufficient state of charge, charge the high-voltage battery. The pre-conditioning is then available again.

Operating requirements

- ▷ The vehicle is in rest state or standby state.
- ▷ The high-voltage battery is sufficiently charged or a charging cable is connected.

If the high-voltage battery is heavily discharged, it may take some time after connecting the charging cable before the pre-conditioning is ready to function.

- ▷ Time and date are set correctly.
- ▷ The air vents of the ventilation are open.

Turning on/turning off the pre-conditioning

Turning on/turning off via iDrive

1. "CLIMATE MENU"
2. "Settings"
3. "Pre-conditioning"
4. Select the desired setting.

Turning on via vehicle key

The system can be switched on using the vehicle key.



Press the button on the vehicle key.

Activate the pre-conditioning function for the button of the vehicle key:

1. "MENU"
2. "Vehicle apps"
3. "Doors and windows"
4. "Vehicle key"
5. Select the desired setting.

Air conditioning for departure time

General

Departure times can be set with time and day of the week.

The switch-on point is determined automatically based on the temperature.

The system is switched on in good time before the set departure time on the required days of the week.

Preselection of departure time is done in two stages:

- ▶ Set the departure times.
- ▶ Activate the departure time.

At least 10 minutes should pass between setting/activating the departure time and the scheduled departure time, so the climate control has enough time to work.

Pre-conditioning will be turned off automatically a few minutes after the set departure time.

Setting the departure time

1. "CLIMATE MENU"
2. "Settings"
3. "Pre-conditioning"
4. "Departure plan"
5. Set the desired departure time.
6. Select the day of the week if necessary.

Activating the departure time

To turn on the pre-conditioning prior to a departure time, the respective departure time must be activated beforehand.

1. "CLIMATE MENU"
2. "Settings"
3. "Pre-conditioning"
4. "Pre-conditioning for departure time"

Display

Icon	Description
	Icon in the upper centre console. Icon is illuminated: heating mode is turned on.
	Icon in the upper centre console. Icon is illuminated: a departure time is activated. Icon flashes: the pre-conditioning is turned on.

Activating with BMW App

An appropriate BMW app with remote function can be used to turn on the pre-conditioning directly or via a preselected departure time.

Interior equipment

Vehicle equipment

This chapter describes equipment, systems and functions which are offered or will be offered on a model-specific basis, even if they are not included in the vehicle in question.

For further information:

Vehicle equipment, see page 7.

Sun visor

Glare protection

Fold the sun visor downwards or upwards.

Protection from glare at the side

Folding the sun visor out

1. Fold down the sun visor.
2. Unhook the sun visor from its holder and pivot it sideways to the side window.

Folding the sun visor in

To close the sun visor, proceed in reverse order.

Vanity mirror

A vanity mirror is located behind a cover in the sun visor.

Ashtray

Front centre console

Opening

1. Press the cover.



2. The ashtray is located in one of the cup holders. Fold up the ashtray cover.



Emptying



With the cover closed, pull the ashtray out of the cup holder.

Cigarette lighter

Safety notes

⚠ WARNING

Contact with the hot heating element or the hot socket of the lighter can cause burns. Flammable materials can catch fire if the lighter is dropped or is held against objects. There is a risk of fire and danger of injury. There is a risk of material damage. Hold lighter by its handle. Ensure that children do not use the lighter.

⚠ NOTE

If metallic objects fall into the socket, they can cause a short circuit. There is a risk of material damage. After using the socket, re-fit the lighter or socket cover.

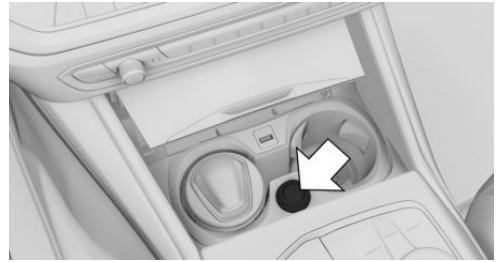

The cigarette lighter is located between the cup holders.

Operation



Press in the cigarette lighter.

The cigarette lighter can be removed when it pops back out.

Front centre console



Press the cover.

Sockets

Principle

The socket can be used for electronic devices when the standby or drive-ready state is switched on.

General

The total load of all sockets must not exceed 140 watts at 12 V.

Do not damage the socket by using unsuitable connectors.

Safety notes

⚠ WARNING

Devices and cables, for example portable navigation devices, that are located in the deployment range of the airbags may impede airbag deployment or be thrown around the vehicle interior when the airbag is deployed. There is a danger of injury. Make sure that devices and

cables are not in the deployment range of the airbags.

NOTE

Battery chargers that charge the vehicle battery via sockets or cigarette lighters in the vehicle may overload or damage the 12 V electrical system. There is a risk of material damage. In the case of a discharged vehicle battery, contact a manufacturer Service Partner or other qualified Service Partner or specialist workshop.

NOTE

If metallic objects fall into the socket, they can cause a short circuit. There is a risk of material damage. After using the socket, re-fit the lighter or socket cover.

Front centre console

1. Press the cover.



2. The socket is located between the cup holders. Pull off the cover.



Inside the luggage compartment

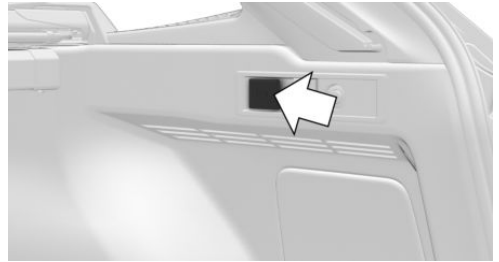

Depending on the equipment, there is a socket in the luggage compartment on the right-hand side. Open the cover.

USB port

General

Please comply with the notes on connecting mobile devices to the USB port in the chapter on USB connections.

For further information:

For information on USB connections, see Owner's Handbook for Navigation, Entertainment, Communication.

In the centre armrest



There is a USB port in the centre armrest.

Properties:

- ▶ USB port type C.
- ▶ For charging mobile devices.

- ▷ Charge current: max. 3 A.
- ▷ With navigation system: for data transfer.

In the front centre console

NOTE

Objects in the storage compartment, for example large USB connectors, can block or damage the cover on opening and closing. There is a risk of material damage. When opening and closing, make sure that the area of movement of the cover is kept clear.



Press the cover.

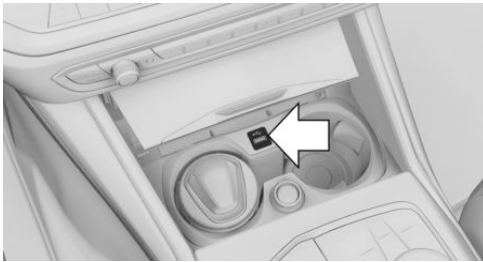

There is a USB port in the centre console.

Properties:

- ▷ USB port type A.
- ▷ For charging mobile devices and transferring data.
- ▷ Charge current: maximum 1.5 A.

In the rear centre console



There are two USB ports in the rear centre console.

Properties:

- ▷ USB port type C.
- ▷ For charging mobile devices.
- ▷ Charge current: maximum 3 A per port.

Wireless charging tray

Principle

The wireless charging tray allows wireless charging of mobile phones and other mobile devices certified according to the Qi standard.

General

When inserting the device to be charged, make sure that there are no objects between the device to be charged and the wireless charging tray.

(⚡) The charging process is indicated by the charging indicator on the control display.

Safety notes

WARNING

When charging a Qi-compatible device in the wireless charging dock, any metal objects located between the device and the dock can become very hot. If storage media or electronic cards, for example smart cards, cards with

magnetic strips or cards for transmitting signals, are placed between the device and the dock, card function may be impaired. There is a risk of injury and material damage. When charging mobile devices, make sure there are no objects between the device and the dock.

Overview

Dock in the centre console:

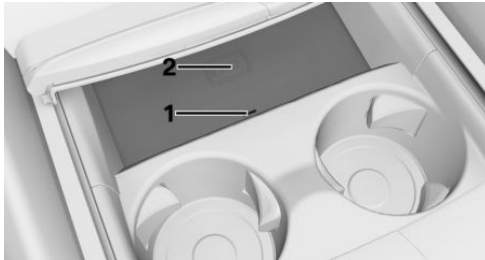

- 1 LED
- 2 Dock surface

Operating requirements

- ▶ The device to be charged must have been certified according to the Qi standard.
- ▶ Standby state is switched on.
- ▶ The maximum size for a mobile phone is approximately 154.5 x 80 x 18 mm, 6.06 x 3.1 x 0.7 in.
- ▶ Only use protective sleeves and covers up to a maximum thickness of 2 mm, 0.07 in, otherwise the charging function may be impaired.
- ▶ The mobile phone to be charged is located in the middle of the dock. The display of the mobile phone faces upwards.

Inserting the mobile phone

1. Open the cover of the dock.
2. Place the mobile phone in the centre of the dock with the display facing upwards.
3. Close the cover of the dock.

LED displays

Colour	Meaning
Blue	The mobile phone is charging. The blue LED stays illuminated once the inserted Qi-compatible mobile phone is fully charged.
Orange	The mobile phone is not charging. The mobile phone may be exposed to excessively high temperature or there may be foreign bodies in the charging dock.
Red	The mobile phone is not charging. Contact a Service Partner of the manufacturer or another qualified Service Partner or a specialist workshop.

Forgotten phone warning

General

A warning can be issued if a mobile phone with Qi certification has been left in the wireless charging tray when leaving the vehicle.

The forgotten phone warning is shown in the instrument cluster.

Activating forgotten warning function

1. "MENU"
2. "Vehicle apps"
3. "System settings"
4. "Wireless charging tray"
5. "Mobile phone reminder"

System limits

The charging process may be reduced or temporarily interrupted in the following situations:

- ▶ Due to excessive temperatures on the surface of the tray and mobile phone.
- ▶ When there are objects between the mobile phone and wireless charging tray.
- ▶ By settings on the mobile phone, for example for charging. Follow the relevant instructions on the control display and in the instructions for the mobile phone, if applicable.

Storage compartments

Vehicle equipment

This chapter describes equipment, systems and functions which are offered or will be offered on a model-specific basis, even if they are not included in the vehicle in question.

For further information:

Vehicle equipment, see page 7.

Safety notes

WARNING

Devices connected by a cable to the vehicle, for example mobile phones, or loose objects may be thrown around the interior during the journey, for example in the event of an accident or when braking or taking avoidance manoeuvre. There is a danger of injury. Ensure that devices connected by cable to the vehicle or loose objects are secured in the interior.

NOTE

Anti-slip mats can damage the instrument panel. There is a risk of material damage. Do not use anti-slip mats.

Glove compartment

Safety note

WARNING

The glove compartment protrudes into the interior when it is open. Objects in the glove compartment may be thrown around the interior during the journey, for example in the event

of an accident or when braking or taking evasive action. There is a danger of injury. Immediately close the glove compartment after using it.

Opening the glove compartment



Pull the handle.

The lighting in the glove compartment comes on.

Closing the fold-down compartment

Shut the lid.

Fold-down compartment

Safety note

WARNING

The glove compartment protrudes into the interior when it is open. Objects in the glove compartment may be thrown around the interior during the journey, for example in the event of an accident or when braking or taking evasive action. There is a danger of injury. Immediately close the glove compartment after using it.

Opening the fold-down compartment



Pull the handle.

Closing the fold-down compartment

Shut the lid.

Storage in the doors

General

There are storage compartments in the doors.

Safety note

WARNING

Breakable objects, for example glass bottles or glasses, may get broken in the event of an accident or when braking or taking evasive action. Splinters may scatter throughout the interior. There is a risk of injury or material damage. Do not use breakable objects during a journey. Only stow breakable objects in closed storage compartments.

Storage compartments in the centre console

Opening



Press the cover.

Closing

Pull back the cover by the the handle strip.

Front centre armrest

General

There is a storage compartment in the centre armrest between the seats.

Opening the centre armrest



Press the button.

Close the centre armrest

Press the cover down until it engages.

Cup holder front

Safety note

WARNING

Unsuitable containers placed in the cup holders may damage the cup holders or be flung into the interior, for example in the event of an accident or when braking or taking evasive action. Spilt liquids can distract the driver from the road and lead to an accident. Hot beverages may damage the cup holders or cause scalding. There is a risk of injury or material damage. Do not force objects into the cup holder. Use light-weight, sealable and shatterproof containers. Do not transport hot drinks.

Opening the cup holder



Press the cover.



There are two cup holders in the centre console.

Closing the cup holder

Pull back the cover by the the handle strip.

Cup holder rear

Safety notes

WARNING

Unsuitable containers placed in the cup holders may damage the cup holders or be flung into the interior, for example in the event of an accident or when braking or taking evasive action. Spilt liquids can distract the driver from the road and lead to an accident. Hot beverages may damage the cup holders or cause scalding. There is a risk of injury or material damage. Do not force objects into the cup holder. Use light-weight, sealable and shatterproof containers. Do not transport hot drinks.

NOTE

If the cup holder is open, the centre armrest cannot be folded back. There is a risk of material damage. Push back the covers before folding up the centre armrest.

Opening the cup holder

1. Fold down the centre armrest.

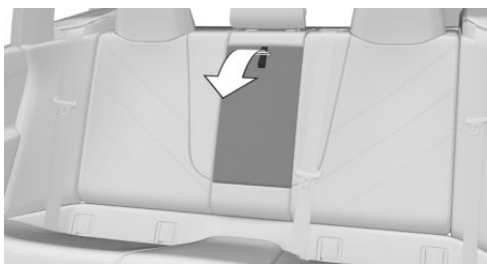

2. To open the cup holder, press the button.

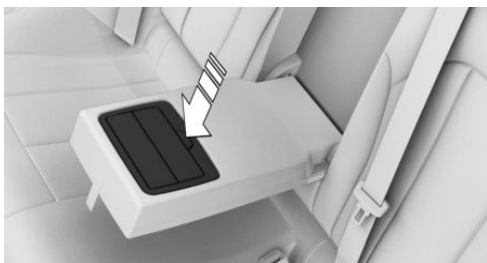

Closing the cup holder

Press both covers back in one after the other and fold back the centre armrest.

Coat hooks

General

The coat hooks are located on the grab handles in the rear.

Safety notes

WARNING

Items of clothing on the coat hooks can impair visibility when driving. There is a risk of accident. Hang items of clothing from the coat hooks in such a way that they do not obstruct visibility when driving.

WARNING

Incorrect use of the coat hooks can present a danger, for example if objects are thrown around as a result of braking or evasive action. There is a risk of injury and material damage. Only hang lightweight objects, for example items of clothing, on the coat hooks.

Luggage compartment

Vehicle equipment

This chapter describes equipment, systems and functions which are offered or will be offered on a model-specific basis, even if they are not included in the vehicle in question.

For further information:

Vehicle equipment, see page 7.

Loading

Safety notes

WARNING

A high gross vehicle weight can make the tyres overheat, causing internal damage and a sudden loss of tyre inflation pressure. Handling characteristics may be adversely affected, for example reduced directional stability, longer stopping distance and altered steering characteristics. There is a risk of accident. Please comply with the permitted load index of the tyre, and do not exceed the permitted gross vehicle weight.

WARNING

If the permitted total weight and the permitted axle loads are exceeded, the operational safety of the vehicle is no longer guaranteed. There is a risk of accident. Do not exceed the permitted total weight and permitted axle loads.

WARNING

Devices connected by a cable to the vehicle, for example mobile phones, or loose objects may be thrown around the interior during the journey, for example in the event of an accident or when braking or taking avoidance manoeuvre. There is a danger of injury. Ensure that devices connected by cable to the vehicle or loose objects are secured in the interior.

WARNING

Incorrectly stowed objects may slip or be thrown into the interior, for example in the event of an accident or when braking or taking evasive action. Vehicle occupants could be struck and injured. There is a danger of injury. Stow and secure objects and the load correctly.

NOTE

Liquids in the luggage compartment may cause damage. There is a risk of material damage. Ensure that no liquids leak out into the luggage compartment.

Stowing and securing loads in the vehicle

- ▷ Wrap protective material around any sharp corners and edges on the load.
- ▷ Heavy loads: stow as far forward as possible, low down and directly behind the rear seat backrests.
- ▷ Very heavy loads: stow as far forward as possible, low down and directly behind the rear seat backrests. If there are no passengers on the rear seat, insert both outer seat belts into the respective opposite buckles.

- ▶ Fully fold down the rear seat backrests if stowing a large load.
- ▶ Do not stack loads above the upper edge of the backrests.
- ▶ Small and lightweight load: secure with tensioning straps or, depending on the equipment, a luggage compartment net or retaining straps.
- ▶ Large and heavy loads: secure with lashing straps.

Lashing eyes in the luggage compartment



There are several lashing eyes in the luggage compartment for securing the load. Load-securing equipment, for example lashing straps, tensioning straps, retaining straps or luggage compartment nets, must be secured to the lashing eyes.

Multifunction hook

General

Depending on the equipment, a multifunction hook is located on the right side in the luggage compartment.

Safety note

WARNING

Incorrect use of the multifunction hooks may present a danger, for example if objects are flung around in the event of braking and avoidance manoeuvres. There is a danger of injury and material damage. Only hang lightweight objects from the multifunction hooks. Only transport heavy luggage in the luggage compartment if suitably secured.

Folding down the multifunction hook

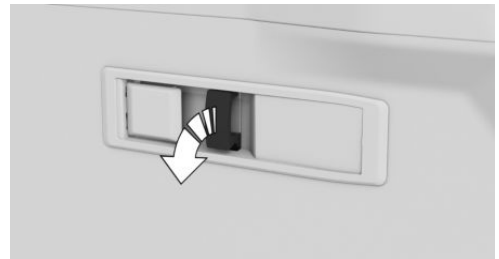

Fold open the multifunction hook until it detectably engages in the lower position.

Net

Depending on the equipment, smaller objects can be stowed in the net on the left or right side. Move the net down to transport larger objects.

Luggage compartment floor

General

There is a storage compartment under the luggage compartment floor.

Opening the storage compartment

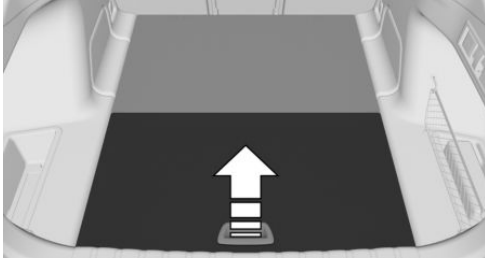

Fold the luggage compartment floor forwards.

Through-loading system

Principle

The luggage compartment can be enlarged by folding down the rear seat backrests.

General

The rear seat backrest is split 40–20–40. The right rear seat backrest and the centre section can be folded down individually. The left rear seat backrest can be folded down together with the centre section.

The rear seat backrests can be folded down from the luggage compartment. The middle section can be folded down separately from the rear.

Safety notes

WARNING

Risk of entrapment when folding down the rear seat backrest. There is a risk of injury or material damage. Before folding down, make sure that the area of movement of the rear seat backrest and the head restraint is kept clear.

WARNING

If a rear seat backrest is not locked, unsecured cargo may be flung into the interior, for example in the event of an accident or when braking or taking evasive action. There is a danger of injury. Make sure that the rear seat backrest is locked after it has been folded back.

WARNING

If the seat is not set properly or the child seat has been installed incorrectly, the child restraint system may have restricted or no stability at all. There is a danger of injury or danger to life. Make sure that the child restraint system rests firmly against the seat backrest. Wherever possible, adapt the backrest angle of all relevant seat backrests and adjust the seats correctly. Make sure that the seats and their backrests are correctly engaged or locked. If necessary, adjust the height of the head restraints, or remove them.

NOTE

Vehicle parts can be damaged when folding down the rear seat backrest. There is a risk of material damage. When folding down, make sure that the area of movement of the rear seat backrest including head restraint is kept clear.

Folding down rear seat backrest

From the rear

1. If necessary, remove the corresponding head restraint.
2. Pull the lever in the recess and fold the rear seat backrest forwards.

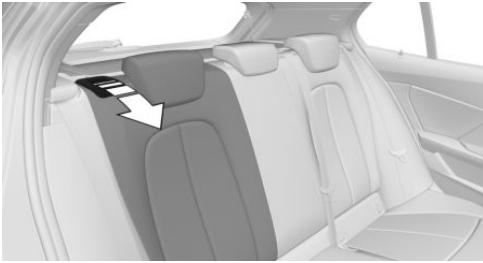

Folding back the rear seat backrest

Fold back the rear seat backrest into the seat position and lock in place. Ensure that the seat belt is not trapped. The red mark behind the recess disappears completely.

Folding down the middle section

1. Fold down the middle head restraint.
2. Pull the lever and fold the middle part forwards.

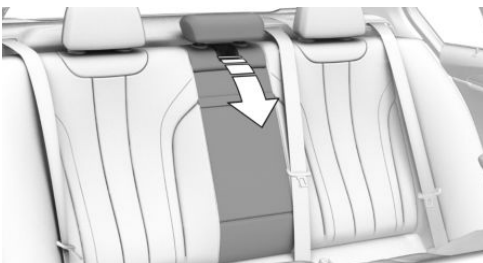

Luggage compartment cover

Safety notes

WARNING

Devices connected by a cable to the vehicle, for example mobile phones, or loose objects may be thrown around the interior during the journey, for example in the event of an accident or when braking or taking avoidance manoeuvre. There is a danger of injury. Ensure that devices connected by cable to the vehicle or loose objects are secured in the interior.

WARNING

If the luggage compartment cover is not inserted correctly, it may be thrown around the interior during the journey, for example in the event of an accident or when braking or taking evasive action. There is a risk of injury and material damage. Make sure that the luggage compartment cover is engaged securely in the brackets.

Removing the luggage compartment covers

The cover can be removed for stowing bulky items.

Cover in the luggage compartment

1. Press the back edge of the luggage compartment cover up and out of the side brackets, arrow 1.



2. Pull out luggage compartment cover, arrows 2.

Cover in the tailgate

1. Open lid at the rear edge, arrow 1, and slightly fold the luggage compartment cover open.

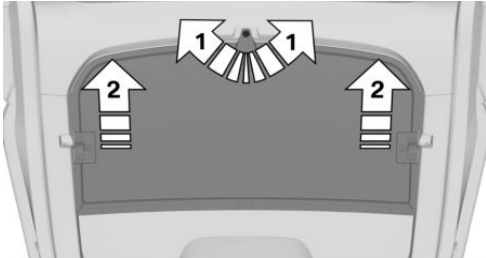

2. Pull the luggage compartment cover up and out of the brackets, arrows 2.

Inserting the covers

To insert, proceed in reverse order. Make sure that the luggage compartment covers are positioned correctly in the brackets and that they are engaged.

Driving precautions

Vehicle equipment

This chapter describes equipment, systems and functions which are offered or will be offered on a model-specific basis, even if they are not included in the vehicle in question.

For further information:

Vehicle equipment, see page 7.

Running in

General

Moving parts need to adjust to each other.

The following notes will help to maximise the vehicle's lifetime and efficiency.

Do not use Launch Control when running in.

Safety note

WARNING

New parts and components can cause safety and driver assistance systems to respond with a delay. There is a risk of accident. After new parts have been installed or if the vehicle is new, drive moderately and take action promptly if necessary. Please comply with running-in procedures for the corresponding parts and components.

Drivetrain

Drive moderately for the first 500 km, approx. 300 miles and avoid full load.

Tyres

Due to the manufacturing process, new tyres do not achieve their full road grip immediately.

Drive moderately for the first 300 km, 200 miles.

Brake system

Brake discs and pads only achieve their full effectiveness after approximately 500 km, 300 miles. Drive moderately during this running-in period.

After fitting new parts

Please comply with the running-in procedures again if the components previously referred to are renewed.

General driving notes

Closing the tailgate

Safety note

WARNING

When open, the tailgate protrudes above the vehicle and in the event of an accident, or when braking or taking avoidance manoeuvre, can endanger vehicle occupants and other road users or damage the vehicle. There is a danger of injury or material damage. Do not drive with the tailgate open.

Driving with the tailgate open

If there is no alternative but to drive with the flap open:

- ▶ Close all the windows and the glass sunroof.
- ▶ Adjust the blower output to a high setting.
- ▶ Maintain a moderate speed.

Ice on the windows

NOTE

The window lowers a little when the door handle is pulled. If there is frost, the window may freeze up and cannot then be lowered. There is a risk of material damage. Make sure that the window lowers when the door handle is pulled. Remove any snow or ice from the window. Do not open the door by force.

Radio signals

WARNING

Certain vehicle functions may be affected by interference from high-frequency radio signals. Such signals are output from a series of transmission systems, for example from air traffic beacons or relay stations for mobile telecommunications.

We recommend you consult your Service Centre should you experience any difficulties.

Mobile radio in the vehicle

WARNING

There is a possibility of reciprocal interference between the vehicle electronics and mobile radio devices. Radiation is generated when mobile radio devices are transmitting. There is a risk of injury or material damage. If possible, only use mobile radio devices, for example mobile telephones, inside the vehicle if they are connected directly to an external aerial in order to eliminate reciprocal interference and to divert the radiation away from the vehicle's interior.

Aquaplaning

On wet or slushy roads, a water wedge can form between the tyres and the road.

This phenomenon is known as aquaplaning and can cause the tyre to lose contact partially or fully with the road surface, meaning that the vehicle can neither be steered, nor the brakes properly applied.

Driving through water

General

Please comply with the following when driving through water:

- ▶ Only drive through still water.
- ▶ Only drive through water up to a max. depth of 25 cm, 9.8 in.
- ▶ Drive through water at a walking speed of no more than 5 km/h, 3 mph.

Safety note

NOTE

Driving through excessively deep water too fast can result in water getting under the front flap or into the electrical system or transmission. There is a risk of material damage. When driving through water, do not exceed the maximum water depth and speed specified above.

Safe braking

General

The vehicle is equipped with an Anti-lock Braking System ABS as standard.

Perform full braking in situations that require it.

The vehicle remains steerable. Steer as smoothly as possible to avoid any obstacles.

A pulsing of the brake pedal and hydraulic regulating sounds indicate that the Anti-lock Braking System ABS is functioning.

In certain braking situations, the perforated brake discs can cause functional noise. However, the functional noises have no effect on the efficiency and operational safety of the brake.

Objects in the movement range of the pedals

WARNING

Objects in the driver's footwell can restrict the pedal travel or block a pedal that has been pressed. There is a risk of accident. Ensure that items in the vehicle are stowed securely and cannot get into the driver's footwell. Only use floor mats that are suitable for the vehicle and can be securely fastened to the floor. Do not use loose floor mats, and do not place several floor mats on top of one another. Make sure that there is sufficient space for the pedals. Ensure that floor mats are securely reattached after removal, for example for cleaning.

Wet roads

In wet weather, road salt exposure and in heavy rain, apply the brakes lightly every few kilometres/miles.

Ensure that you do not obstruct other road users when doing so.

The heat generated by braking dries the brake discs and brake pads and protects them against corrosion.

This helps to maintain braking power so that it is available immediately when needed.

Downhill gradient

General

Change gear using shift paddles or selector lever position D/L, depending on the equipment.

Energy recuperation can affect the braking effect of the drive system.

Safety notes

WARNING

Even slight but continuous pressure on the brake pedal can cause overheating, brake pad wear or even brake system failure. There is a risk of accident. Avoid excessive loads on the brake.

WARNING

In idle or with drive-ready state switched off, safety-relevant functions are restricted or no longer available, for example the braking effect of the drivetrain or power assistance for the braking force and steering. There is a risk of accident. Do not drive in idle or with the drive-ready state switched off.

Corrosion of the brake disc

Corrosion of the brake discs and contamination of the brake pads increase in the following circumstances:

- ▷ Low mileage.
- ▷ Extended stationary periods when the vehicle is not used.
- ▷ Infrequent use of the brakes.
- ▷ Aggressive, acidic or alkaline cleaning agents.

During braking, corroded brake discs may cause juddering which usually cannot be eliminated.

Condensation when vehicle is parked

When the automatic air conditioning is operating, condensation develops and exits underneath the vehicle.

Roof rack

General

Roof racks are available as optional accessories.

Safety note

⚠ WARNING

When driving with a roof load, for example with a roof rack, the higher centre of gravity can mean that driving safety is no longer guaranteed in critical driving situations. There is a risk of accident or material damage. Driving with roof load only with activated Dynamic Stability Control.

Fitting

Follow the installation instructions for the roof rack.

Make sure that there is sufficient space to raise and open the glass sunroof.

Loading

A loaded roof rack alters the vehicle's road behaviour and steering response by shifting its centre of gravity.

Therefore when loading and driving, bear the following in mind:

- ▶ Do not exceed the permitted roof and axle load or the permitted total weight.
- ▶ Make sure that there is sufficient space to raise and open the glass sunroof.
- ▶ Distribute the roof load evenly.
- ▶ The roof load must not be spread over too large an area.
- ▶ Place heavy items of luggage at the bottom.
- ▶ Securely fasten the luggage, for example with tensioning straps.
- ▶ Do not allow objects to protrude into the swing range of the tailgate.
- ▶ Drive cautiously and avoid driving off and braking suddenly or fast cornering.

Rear luggage rack

Principle

The ball head of the trailer tow hitch can be used as a mount for rear luggage racks, for example bicycle carrier systems.

General

Rear luggage racks which the manufacturer has classified as suitable are available as optional accessories.

Bicycle carrier systems for up to three bicycles can be used.

Fitting

Follow the installation instructions for the rear luggage rack.

Loading

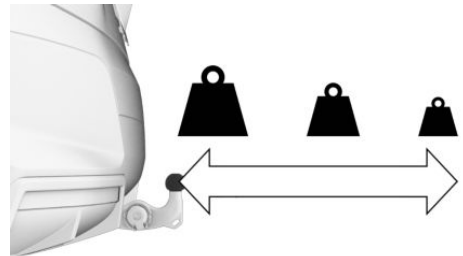

The permitted total weight of the rear luggage rack when loaded depends on how far its centre of gravity is from the ball head.

- ▶ If the centre of gravity is up to 30 cm, 11.8 in away from the ball head, the total weight of the rear luggage rack must not exceed 75 kg/165 lbs.
- ▶ If the centre of gravity is 60 cm, 23.5 in from the ball head, the total weight of the rear luggage rack must not exceed 35 kg/77 lbs.
- ▶ Stow heavy loads as close as possible to the ball head.
- ▶ Fasten loads securely to the rear luggage rack and secure them against sliding around.

Before a journey

Before the start of a journey, check that the rear lights on the rear luggage rack are working.

The maximum output of the rear luggage rack rear lights must not exceed the values for trailer rear lights.

To prevent functional limitations and malfunctions affecting driver assistance systems, activate trailer operation.

For further information:

- ▶ Power consumption, see page 304.
- ▶ Activating trailer operation, see page 306.

Driving with a rear luggage rack

Loaded rear luggage racks change the driving and steering behaviour of the vehicle by shifting the centre of gravity.

Therefore when loading and driving, bear the following in mind:

- ▶ Do not exceed the permitted axle load or the permitted total weight.
- ▶ Drive cautiously and avoid driving off and braking suddenly or fast cornering.

Driving on a racetrack

WARNING

The vehicle is not designed for use in M Sport competitions or similar. There is a risk of accident. Do not use the vehicle in M Sport competitions or similar.

The higher mechanical and thermal loads involved when driving on racetracks lead to increased wear. This wear is not covered by the warranty.

Before and after driving on a racetrack, have the vehicle checked at a Service Partner of the manufacturer or another qualified Service Partner or a specialist workshop.

Trailer operation

Vehicle equipment

This chapter describes equipment, systems and functions which are offered or will be offered on a model-specific basis, even if they are not included in the vehicle in question.

For further information:

Vehicle equipment, see page 7.

General

The permitted trailer loads, axle loads, trailer nose weights and permitted total weight rating are specified in the technical data.

Consult a Service Partner of the manufacturer or another qualified Service Partner or a specialist workshop about options for increasing the loads.

The vehicle is equipped with reinforced springs on the rear axle and, depending on the vehicle type, with a more powerful cooling system.

For Australia: note

Towing

The Australian/New Zealand Standards AS 4177.1-2004 Caravan and light trailer towing components – trailer tow hitches and towing brackets includes the following statement which BMW Group Australia herewith adopts: FOR TRAILER TOWING ONLY. The trailer tow hitch supplied with your BMW vehicle should only be used for towing purposes, the trailer tow hitch assembly should not be used in conjunction with any towbar-mounted carrying device, such as, for example, a bicycle carrier.

As all BMW Group towbar assemblies are designed, tested and approved as a single unit, the practice of modifying or replacing the BMW sup-

plied towball mount assembly is not approved. Use only the genuine BMW towball mount assembly.

BMW Group Australia does not recommend or support the installation and use of a Weight Distribution Hitch or Load Levelling Device on any BMW Group vehicle. The use of such devices may affect the vehicle's warranty status.

We recommend you consult your Authorised BMW Dealer for any further advice or clarification.

Before a journey

Trailer nose weight

The trailer nose weight should not be less than the minimum trailer nose weight of 25 kg, 55 lb. Utilise the maximum trailer nose weight as far as possible.

The weight of the trailer tow hitch and the trailer nose weight reduce the maximum load of the towing vehicle. The trailer nose weight increases the vehicle weight. Do not exceed the permitted total weight of the towing vehicle.

Loading

Distribute the load as evenly as possible over the loading area.

Stow the load as low down as possible and as close as possible to the trailer axle. A low centre of trailer gravity makes the car/trailer combination much more stable and safe to drive.

The permitted total weight of the trailer and the permitted trailer load of the vehicle must not be exceeded. The lower value is the limit which should be adhered to.

Tyre inflation pressure

Check the vehicle's and the trailer's tyre inflation pressures carefully.

On the vehicle, the tyre inflation pressure for higher loads applies.

For the trailer, the regulations of the manufacturer apply.

For further information:

Tyre inflation pressure information, see page [327](#).

Flat tyre monitor RPA

Initialise the flat tyre monitor after the tyre inflation pressure has been corrected or a trailer has been attached or detached.

For further information:

Flat tyre monitor RPA, see page [345](#).

Tyre Pressure Monitor

Reset the Tyre Pressure Monitor after the tyre inflation pressure has been corrected or a trailer has been attached or detached.

For further information:

Tyre Pressure Monitor, see page [338](#).

Exterior mirrors

Two exterior mirrors which bring both rear corners of the trailer into your field of view are required by law. Mirrors of this type are available as optional accessories from a Service Partner of the manufacturer or another qualified Service Partner or a specialist workshop.

Power consumption

General

Before the start of a journey, check the function of the trailer rear lights.

When towing a caravan, only operate power consumers briefly to avoid placing an excessive load on the vehicle battery.

Not Australia/New Zealand: Trailer rear lights

The power output of the trailer's rear lights must not exceed the following values:

- ▷ Turn indicators: 42 watts per side.
- ▷ Rear lights: 50 watts per side.
- ▷ Brake lights: 84 watts total.
- ▷ Rear fog lights: 42 watts total.
- ▷ Reversing lights: 42 watts total.

Australia/New Zealand: Trailer rear lights

- ▷ Turn indicators: 54 watts per side.
- ▷ Rear lights: 100 watts in total.
- ▷ Brake lights: 108 watts total.
- ▷ Reversing lights: 54 watts total.

Towing a trailer

General

When the trailer socket is occupied, some driver assistance systems are unavailable, or available only to a restricted extent. A Check Control message is shown where applicable.

In order to avoid malfunctions, activate trailer operation.

For further information:

Activating trailer operation, see page [306](#).

Safety notes

WARNING

Speeds in excess of approximately 80 km/h, 50 mph, can be enough to produce snaking motion, depending on the design of trailers and the loads they are carrying. There is a risk of accident or material damage.

Keep to an appropriate speed when towing a trailer. If the trailer starts to snake, brake immediately and make the necessary steering corrections as carefully as possible.

WARNING

The tyre inflation pressure must be adapted because of the increased axle load when towing a trailer. Driving with inadequate tyre inflation pressure can damage the tyres. There is a risk of accident or material damage. Do not exceed a speed of 100 km/h / 60 mph. Increase the tyre inflation pressure of the towing vehicle by 0.2 bar. Note the maximum possible tyre inflation pressure stated on the tyre.

Upward gradients

General

In the interest of safety and to avoid holding up other traffic flow, do not attempt to climb upward gradients steeper than 12 % in trailer operation. If higher trailer loads have been retrospectively approved, the limit is 8 %.

Driving off on upward gradients

The parking brake is automatically released when the accelerator pedal is operated.

To prevent the vehicle from rolling back when driving off, use the parking brake.

1.  Shortly before driving off, pull and release the switch.
The parking brake is engaged.
2. To drive off, press the accelerator pedal with sufficient force.

Downhill gradient

On downward gradients, a car/trailer combination tends to start snaking movement earlier.

Before the downhill gradient, shift down manually to the next-lowest gear and drive downhill slowly. Change gear using shift paddles or selector lever position D/L, depending on the equipment.

Trailer Stability Control

Principle

Trailer Stability Control assists in intercepting trailer snaking movements.

The system detects snaking movements and promptly brakes the vehicle so that the vehicle speed falls to below the critical speed range and the outfit is stabilised.

General

The system can also become active in extreme driving situations when the trailer socket is occupied without a trailer attached, for example when using a bicycle carrier with lighting.

Operating requirements

The system is operational from a speed of approximately 65 km/h, 40 mph in trailer operation and with the trailer socket occupied.

System limits

The system is unable to intervene or intervenes too late, in the following situations for example:

- ▶ If a trailer folds instantly, for example on slippery or loose road surfaces.
- ▶ If a trailer with a high centre of gravity tips over before snaking movement is detected.
- ▶ If Dynamic Stability Control is deactivated or has failed.
- ▶ If the power consumption of a trailer is too low to be detected by the system, for example due to LED rear lights.

Activating trailer operation

General

When driving with a trailer or load carrier and the trailer socket is not occupied, some driver assistance systems may only operate to a limited extent or may malfunction. In order to avoid malfunctions, activate trailer operation.

Activating trailer operation

1. "MENU"
2. "Vehicle apps"
3. "Driving settings"
4. "Driver assistance"
5. "Driving"
6. "Trailer mode"
7. Select the desired setting.

Not for Australia: Trailer tow hitch with electrically adjustable ball head

General

The adjustable ball head is located on the underside of the vehicle.

Safety notes

WARNING

If the ball linkage is not locked, unstable driving conditions or accidents can result. There is a risk of accident or material damage. Before a journey with a trailer or load carrier, check that the ball linkage is correctly locked.

If the ball linkage is not properly locked, the LED in the button illuminates red.

NOTE

The trailer tow hitch is intended to be used with a trailer. If the ball linkage of the trailer tow hitch has been swivelled out, it may become jammed when driving without a trailer or load carrier. There is a risk of material damage. Swivel the ball linkage back in when driving without a trailer or load carrier.

Overview

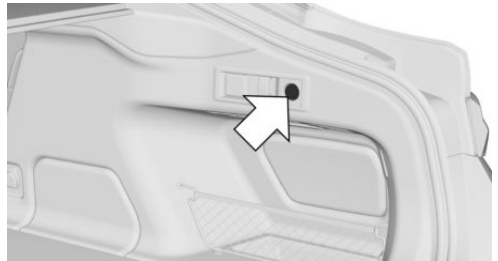

The button for swivelling the ball head in and out is in the luggage compartment.

Operating requirements

- ▶ Vehicle is standing on level ground.
- ▶ The tailgate is open.
- ▶ The trailer socket is not occupied.
- ▶ Trailer operation is not activated.
- ▶ The vehicle battery is sufficiently charged.

The LED in the button illuminates green if the system is operational.

Swivelling out the ball head

1. Open the luggage compartment.
2. Step out of the swing range of the ball head behind the vehicle.



3. Press the button in the luggage compartment.

The ball head swivels out. The LED flashes green.

4. Wait until the ball head has reached the end position.

The LED in the button illuminates green when the ball head has reached an end position.

Swivelling the ball head back in

1. Disconnect the trailer or load carrier.
2. Remove any fittings for the track-stabilising devices.
3. Remove the power supply connector for the trailer and any adapter from the socket.

4.  Press the button in the luggage compartment.

The ball head swivels inwards. The LED flashes green.

5. Wait until the ball head has reached the end position.

The LED in the button illuminates green when the ball head has reached an end position.

Interruption or reversal of the swivel movement

General

The swivel movement is interrupted, might be reversed or is not performed if electrical current limits are exceeded, for example at very low temperatures, or if mechanical resistance is encountered. LED illuminates red.

Repeating the swivel movement with the drive-ready state switched on

1. Switch on drive-ready state.

2.  Press the button in the luggage compartment and hold it until the ball head has moved completely in or out.

If necessary, repeat the swivel movement with the button pressed and drive-ready state switched on.

The LED in the button illuminates green when the ball head has reached an end position.

If the swivel movement is repeatedly interrupted, contact a Service Partner of the manufacturer or another qualified Service Partner or a specialist workshop.

Trailer socket



The trailer socket is located on the trailer tow hitch.

Fold down the cover.

Eye for securing cable

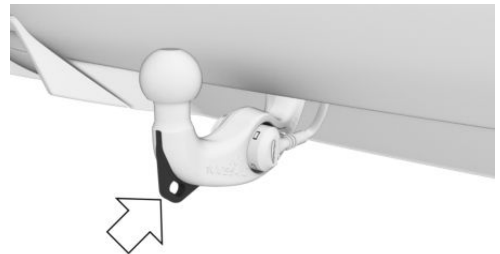

There is an eye on the trailer tow hitch for fastening the trailer securing cable.

For increased safety when towing a trailer, attach the trailer securing cable to the eye.

Check that the securing cable can move freely and is not dragging on the ground.

Operating rear luggage racks

The ball head of the trailer tow hitch can be used as a mount for rear luggage racks, for example bicycle carrier systems.

Note the information on rear luggage racks when operating the rear luggage rack.

For further information:

Rear luggage rack, see page [301](#).

Increasing range

Vehicle equipment

This chapter describes equipment, systems and functions which are offered or will be offered on a model-specific basis, even if they are not included in the vehicle in question.

For further information:

Vehicle equipment, see page 7.

Increasing range

General

The vehicle contains extensive technologies to reduce energy consumption and maximise range.

A number of measures, such as driving style and regular service can increase the range.

For further information:

Range, see page 165.

Remove unnecessary loads

Extra weight decreases range.

Remove mounted parts after use

Remove auxiliary mirrors, roof racks or rear carriers after use if they are no longer required.

Parts mounted on the vehicle can adversely affect its aerodynamics and increase energy consumption.

Closing windows and glass sunroof

An open glass sunroof or open window increases drag and consequently reduce the range.

Tyres

General

Tyres can have differing effects on energy consumption. For example, energy consumption can be affected by tyre size.

Check tyre inflation pressure regularly

Check and, if necessary, correct the tyre inflation pressure at least twice a month and before setting off on a longer journey.

Insufficient tyre inflation pressure increases rolling resistance and consequently energy consumption and tyre wear.

For further information:

Tyre inflation pressure information, see page 327.

Pre-conditioning

Activate preliminary air conditioning in the vehicle during charging before starting the trip.

Heating and cooling processes are very energy-intensive and decrease the electric range considerably.

For further information:

Pre-conditioning, see page 280.

Think ahead

Anticipating the road situation and adopting a smooth driving style will reduce energy consumption.

Avoid accelerating and braking unnecessarily.

To do so, keep an appropriate distance from the vehicle ahead.

Use the accelerator pedal for decelerating and rolling to a stop

When approaching a red light, use the accelerator or brake pedal to decelerate at an early stage.

Use the coasting function when driving downhill. Press accelerator pedal just until the vehicle rolls.

With adaptive recuperation: do not press the accelerator pedal. Coasting and deceleration are automatically adapted to the driving situation in question.

Switch off functions which are not currently required

Functions such as seat heating or rear window heating require a great deal of energy and reduce the range, especially in city traffic and stop-and-go traffic.

Switch these functions off if they are not required.

The ECO PRO drive mode supports energy-saving use of comfort functions. These functions are automatically deactivated wholly or partially.

Have maintenance work carried out

For optimum economy and service life, have the vehicle serviced regularly. BMW recommends having maintenance work carried out by a BMW Service Partner.

Please also comply with the BMW Maintenance System.

ECO PRO

Principle

ECO PRO supports an efficient driving style. The control of the drivetrain is optimised for moderate acceleration and light and comfort functions, including air conditioning output, for example, are adapted.

General

The system comprises the following EfficientDynamics functions and EfficientDynamics displays:

- ▷ ECO PRO seat climate control.
- ▷ ECO PRO air conditioning.
- ▷ ECO PRO view.
- ▷ Route-ahead Assistant
- ▷ Driving style analysis

Overview

Button in the vehicle

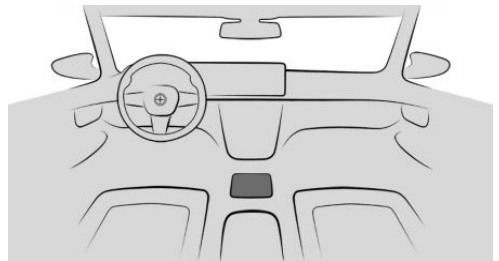

ECO PRO

Selecting the drive mode

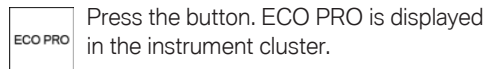

Press the button. ECO PRO is displayed in the instrument cluster.

Configuring ECO PRO INDIVIDUAL

Via iDrive

1. "MENU"
2. "Vehicle apps"
3. "Driving settings"
4. "Drivetrain and chassis"
5. "ECO PRO INDIVIDUAL"
6. Select the desired setting.

Activating/deactivating ECO PRO functions

The following ECO PRO functions can be activated/deactivated:

- ▷ ECO PRO seat heating.
- ▷ ECO PRO air conditioning.
- ▷ ECO PRO view.

ECO PRO seat climate control

The output of the seat heating is reduced when ECO PRO is activated.

ECO PRO air conditioning

The air conditioning is adjusted for efficient consumption.

To achieve this, the set temperature is adjusted slightly and the interior is heated or cooled more slowly to reduce consumption.

ECO PRO view

The power output of the exterior mirror heating and the rear window heating is reduced.

Depending on the equipment, the dynamic ECO lighting function is activated additionally.

Resetting settings



1. Press the button.
2. "Settings"
3. "Reset to ECO PRO STANDARD"

Using eDRIVE efficiently

Principle

eDRIVE works automatically. By adopting an anticipatory driving style, the drive system characteristics can be used to optimum effect, in other words energy consumption and energy recuperation are optimised. Energy recuperation is for charging the high-voltage battery. Energy recuperation is important for supplying the electrical components and essential for achieving a long range. Energy recuperation and energy consumption depend on driving as well as other factors.

peration is important for supplying the electrical components and essential for achieving a long range. Energy recuperation and energy consumption depend on driving as well as other factors.

Optimising driving style

Power display

When activating the ECO PRO drive mode, the display changes to a special display.

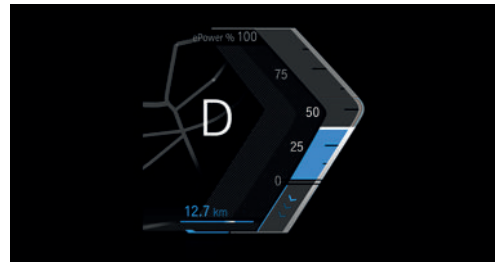

When driving efficiently, the power display is coloured blue.

The display will change to grey if the driving style is inefficient.

For efficient driving style, activate adaptive recuperation

For further information:

Driving in detail: eDRIVE, see page 141.

Display inefficient driving style



When driving above the efficient range, an arrow will be displayed.

For example, the display occurs in the following situations:

- ▷ Excessive acceleration.
- ▷ Excessive speed.
- ▷ Special route section, for example roundabout ahead.

In addition, a deceleration notification is displayed.

Predictive driving style

Principle

The display informs the driver about decelerations ahead, for example, speed limit reductions or roundabouts, even when they are not yet visible. The situation-specific information and distance to the route section ahead is shown above the current speed limit in the instrument cluster. If there is a note, the speed can be reduced in way that saves energy using the corresponding accelerator pedal position for rolling.

Display in the instrument cluster

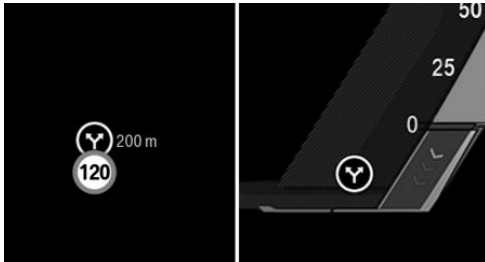

A note regarding a section of the route ahead is given as a recommendation to allow the vehicle to roll.

An icon, for example a turn, indicates the detected section of the route:

Icon	Section of the road in front
	Speed limit or town entrance.
	Roundabout.
	Corner.

System limits

For example, the display of the upcoming route sections is not available in the following situations:

- ▶ With temporary and variable speed limits, for example, at road works.
- ▶ In the case of navigation data that is invalid, outdated or not available.
- ▶ If there are country-dependent restrictions on map-based route sections.

Driving style analysis

Principle

The function helps develop a particularly efficient driving style and to save energy.

It does this by analysing your driving style. The evaluation is performed in various categories and is shown on the control display.

Using this display, the individual driving style can be adjusted to save energy.

General

Adapting the driving style can increase the range of the vehicle.

The current trip is analysed.

Operating requirements

The function is available in ECO PRO drive mode.

Go to efficiency evaluation

1. "MENU"
2. "Vehicle apps"
3. "Live Vehicle"

For further information:

Live Vehicle, see page [171](#)

Display on the control display

The display of the efficiency analysis shows the efficiency of the driving style.

The more efficient the driving style, the larger the bars of the evaluation categories.

In contrast, a reduced area will be displayed with an inefficient driving style.

Adaptive recuperation

Principle

Adaptive recuperation supports an anticipatory and comfort-oriented driving style. Map data and various sensors analyse the current driving situation, for example the distance to the vehicle in front.

General

Adaptive recuperation is available depending on the equipment and national-market version.

Based on the situation, the system decides whether and the extent to which energy is recovered through recuperation, or how the vehicle rolls. Depending on the strength of the recuperation, the vehicle is decelerated differently while coasting.

Display

Display in the instrument cluster

The adaptive recuperation can be displayed in the instrument cluster.

For further information:

Power display, see page [163](#).

Display on the control display

The adaptive recuperation can be displayed on the control display.

For further information:

Current driving condition, see page [173](#).

Activating the recuperation

1. "MENU"
2. "Vehicle apps"
3. "Driving settings"

4. "Drivetrain and chassis"
5. "Energy recovery in D"
6. Select the desired setting.

Coasting

Principle

The electric drivetrain allows it to roll without energy consumption. This drive state is called coasting.

Coasting is automatically adapted to the driving situation in question.

If the vehicle rolls, no energy is recuperated.

Examples of driving situations

If a route can be covered without foreseeable braking, it is advantageous to roll on this route.

The following examples of driving situations may be suitable for this:

- ▶ Rolling on straight downhill gradient with no obstacles.
- ▶ Rolling to a stop on a section of route without obstacles.

Avoid late or heavy braking.

Operating requirements

- ▶ Selector lever position D is engaged.
- ▶ Adaptive recuperation is activated.
- ▶ Dynamic Stability Control is activated.
- ▶ Brake is not depressed.
- ▶ Accelerator pedal is not operated.

System limits

- ▶ In the case of navigation data that is invalid, outdated or not available.
- ▶ If there are country-dependent restrictions on map-based route sections.
- ▶ With a temporary and variable speed limit, such as at road works.

- ▶ If Cruise Control is active.
- ▶ If the sensors are faulty, soiled or covered.

Charging vehicle

Vehicle equipment

This chapter describes equipment, systems and functions which are offered or will be offered on a model-specific basis, even if they are not included in the vehicle in question.

For further information:

Vehicle equipment, see page 7.

General

The vehicle can be recharged with various charging cables at charging stations, domestic socket outlets or industrial socket outlets.

The charging process is controlled and monitored fully automatically. The charge current intensity can be set using iDrive.

Safety notes

WARNING

Incorrect handling of electric current can cause an electric shock due to high voltages or powerful current. There is a risk of fire or death. Follow the general safety regulations when working with electric current.

WARNING

A defective and wrongly configured charging point at the charging location may damage to the vehicle and overload the power system at the charging location. There is a risk of fire and injury.

Before the first charging process, have the following components of your own charging point checked by a qualified electrician at the charging location:

- ▷ Charging cable.
- ▷ Charging station.
- ▷ Domestic socket outlet and connected circuits.

WARNING

Damaged or worn charging points, for example worn contacts, can heat up. There is a risk of fire. Only use a charging point that is in perfect condition.

WARNING

Touching live components can result in an electric shock. High voltage is present at the charging socket. There is a risk of injury or even death. Have work on the charging socket, for example cleaning, performed by a Service Partner of the manufacturer or another qualified Service Partner or a specialist workshop.

NOTE

The connected charging cable and charging cable connections on the vehicle may be damaged due to mechanical load. There is a risk of material damage. Do not apply mechanical loads to the charging cable and the charging cable connections. Route the charging cable to the vehicle freely and avoid pulling or bending.

High-voltage battery

The high-voltage battery serves as energy storage. The high-voltage battery can be charged by energy recuperation during a journey or from the mains.

For optimum operation of the high-voltage battery, charge the vehicle regularly at a suitable charging point.

The following different options are available for charging from the mains:

- ▶ Domestic socket outlet.
- ▶ Industrial socket.
- ▶ AC charging station.
- ▶ DC charging station.

For optimum use of energy from the grid, charging at a charging station, for example BMW Wallbox, is recommended.

The BMW Wallbox must meet the following technical requirements:

- ▶ Three-phase charging power of at least 11 kW.
- ▶ Charge current intensity of 16 A.

Charge current

General

Charge current intensity is specified in amps.

The vehicle cannot automatically detect the maximum permitted charge current intensity of the grid when charging at a domestic socket outlet.

Safety note

WARNING

If the charge current intensity is set incorrectly, the power supply of the domestic socket outlet can be overloaded and overheat. There is a risk of fire. Before charging at domestic socket outlets, adapt the charge current intensity to the

power supply. Set to the lowest level if the power supply is unknown.

Charging at a domestic socket outlet

Before charging for the first time at your own domestic socket outlet, and when charging at other domestic socket outlets, first find out the permitted charge current level, for example by consulting a qualified electrician.

Current limitation

General

The current limitation for charging with the Mode 2 charging cable and the Mode 3 charging cable can be set via iDrive.

Depending on the electrical mains, the set charging current strength may have to be rechecked. Determine the approved charge current level before using a domestic socket outlet for charging, for example by a qualified electrician.

If the approved charging current strength is unknown, set the current limitation to the lowest level.

Activating/deactivating current limitation

1. "MENU"
2. "Vehicle apps"
3. "Charging"
4. "Current limit"
5. "Current limit"

The set current limitation is activated or deactivated.

Setting current limitation

1. "MENU"
2. "Vehicle apps"
3. "Charging"
4. "Current limit"
5. Select the desired setting.

The setting is saved. When changing the charging point change the setting accordingly.

Charging cable ID

The charging cable and high-voltage charging socket feature an ID. The ID indicates whether the charging cable and high-voltage charging socket are compatible.

When the identification on the charging cable matches with one of the identifications on the charging socket, a charging process is possible.



AC charging via a Mode 2 charging cable or Mode 3 charging cable or DC charging via a DC charging cable.

Charging cable

General

To charge the vehicle, use a mode 2 charging cable, a mode 3 charging cable or a fixed cable of a charging station.

Depending on the national-market version, different charging cables are required and are included in the vehicle delivery specification.

It may be possible to perform settings on the charging cable. Do not change the default setting on the charging cable.

Safety notes

WARNING

Incompatible charging cables or unsuitable charging stations can heat up and cause damage to the vehicle. There is a risk of fire. For charging, use charging cables or charging stations that have been classified as suitable for the corresponding type of vehicle.

Information on suitable charging cables can be asked for at the Service Partner of the manufacturer.

WARNING

Incorrect use of the charging cable can prevent the charging process and lead to damage, for example a cable fire. There is a risk of fire. Only use the charging cable for charging the vehicle and do not extend it with a cable or adapter.

WARNING

Damaged charging cables can heat up or cause an electric shock. There is a risk of fire or injury. Only use undamaged charging cables.

WARNING

An incorrectly connected charging cable can lead to damage, for example cable fire. There is a risk of injury or material damage. Ensure that the charging cable plug has been fully inserted into the socket.

AC charging cable

Mode 2 charging cable

The mode 2 charging cable permits charging at domestic socket outlets with protective earth. The power supply at a domestic socket outlet uses alternating current to charge the vehicle.

When using the mode 2 charging cable, the efficiency values may differ from those of the energy label.

The mode 2 charging cable is also referred to as a standard charging cable.

Flexible Fast Charger

The Flexible Fast Charger is a special mode 2 charging cable.

The interchangeable power plugs of the Flexible Fast Charger allow flexible charging at domestic or industrial socket outlets with protective conductors.

Mode 3 charging cable

The mode 3 charging cable enables fast charging at sockets of designated AC charging stations through a special connector. Alternating current is used to charge at designated AC charging stations. The charging process can be completed faster than with domestic socket outlets.

A charge current level of up to a maximum of 16 A is possible.

The charging cable may be permanently installed at the charging station.

The mode 3 charging cable is also referred to as an AC quick charging cable.

Rapid charging cable

The rapid charging cable permanently installed on the charging station allows charging at DC charging stations. Direct current is used for charging at designated DC charging stations. The DC charging station has a higher rated power supply and the charging time is usually considerably shorter compared with a domestic socket outlet or AC charging station.

When charging at a DC charging station, a note is shown on the instrument cluster.

Charge the vehicle only with a DC charging cable less than , 30 m approx. 98 ft in length.

The rapid charging cable is also referred to as a mode 4 charging cable.

Storage

On delivery, the charging cable is stowed in the luggage compartment, for example under the luggage compartment floor or in a bag.

Put the charging cable back in the same place after use.

If the charging cable is stowed in a bag, secure the bag to an unused lashing eye in the luggage compartment.

If necessary, store the charging cable with attached plug cover to avoid moisture in the charging cable plug.

Connecting a charging cable

General

Before connecting, clean the area between the charging socket flap and charging socket outlet and the charging cable plug if necessary, for example remove any snow.

Charging socket flap



The charging socket flap is located in the rear on the right side of the vehicle.

Keep the high-voltage charging socket clean and unobstructed.

Keep the charging socket flap and, if applicable, the charging socket cover, closed when the charging socket is not in use.

Connecting a charging cable

To connect, engage selector lever position P, deactivate drive-ready state and unlock the vehicle. Apply the parking brake, if necessary.

1. To open the charging socket flap, press on the rear edge, arrow.

The charging socket flap opens.

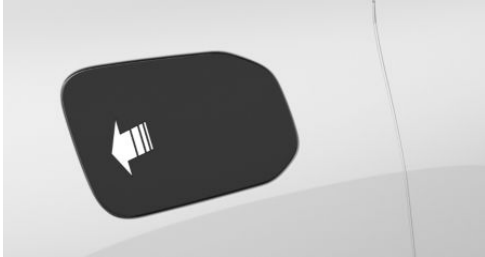

2. Open the charging socket flap.

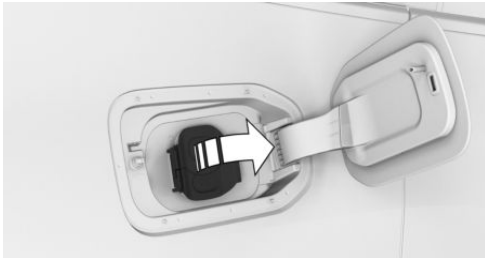

3. Remove the cover from the charging cable connector if necessary.
4. As applicable, connect the mode 2 charging cable to the domestic socket outlet or the mode 3 charging cable to the connection point on the AC charging station.
5. Place the charging cable plug into the charging socket outlet and press it in as far as it will go.
6. Briefly hold the charging cable until the charging cable is locked correctly.
7. When charging at a charging station, follow the instructions at the charging station if necessary.

Removing the charging cable

General

During the charging process, the charging cable is automatically locked. Unlock the charging cable before removing.

Before removing, clean the area between the charging socket flap and the charging socket outlet, for example to remove snow.

Removing a charging cable

1. Unlock vehicle or unlock charging cable via iDrive.

The charging process is finished.

The charging cable is unlocked for a short time.

2. Hold the charging cable at the grips.
3. Remove the charging cable from the high-voltage charging socket, arrow.

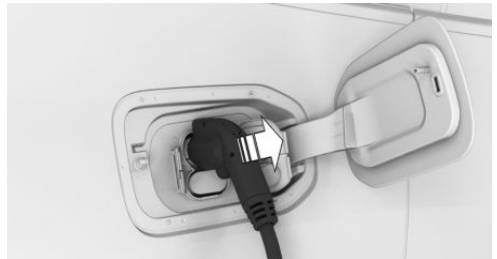

4. Close the charging socket cover.
5. Press the charging socket flap closed until it engages.
6. Where applicable, fit cover on charging cable connector.
7. If applicable, disconnect the mode 2 charging cable from the domestic socket outlet or the mode 3 charging cable from the connection point at the AC charging station.
8. Stow the charging cable if necessary.

At a charging station, insert the permanently installed charging cable into the place provided for this purpose.

Unlocking the charging cable

Principle

The charging cable is unlocked when the vehicle is unlocked. The charging cable can also be unlocked via iDrive.

Unlocking the charging cable via iDrive

1. "MENU"
2. "Vehicle apps"
3. "Charging"
4. "Unlock charging cable"
5. "Unlock charging cable now"
6. "Stop and unlock charging cable"

Additional settings

1. "MENU"
2. "Vehicle apps"
3. "Charging"
4. "Unlock charging cable"
5. Select the desired setting:
 - ▶ "Unlock charging cable when charging finishes": the charging cable is automatically unlocked as soon as the charging process has finished.
 - ▶ "Unlock charging flap permanently": the charging socket flap can be permanently unlocked so that it can be opened even when the vehicle is locked.

Charging process

Principle

Charging can be adapted to accommodate various constraints, for example, electricity costs, available electricity source or low ambient temperature. The vehicle controls the charging process so that the charging is completed if possible by a departure time. To do so, a departure time must be set.

General

High or low outside temperatures can cause longer charging times.

When charging the vehicle, a target charge can be set, shortening the charging time.

When the route guidance to a DC charging station has been started, the pre-temperature of the high-voltage battery is set in advance as best as possible before the destination is reached. This increases the charging capacity during the charging process and shortens the charging time. The pre-temperature setting takes factors such as remaining range or outside temperatures into account.

If the mode 2 charging cable is exposed to high temperatures and direct sunlight, this may interrupt the charging process. Charging process resumes automatically.

The charging process will be interrupted or will not be started when a Remote Software Upgrade is installed. The charging process may not resume automatically after successful installation.

Safety notes

NOTE

Placing weight on the charging socket flap and the charging socket outlet cover may cause damage. There is a risk of material damage. Do not put weight onto the charging socket flap and the charging socket outlet cover, for example, by setting down the charging cable.

Starting the charging process

1. Engage the selector lever in position P. Apply parking brake if necessary.
2. Plan the charging process.
Charging process scheduling, see page 324.
3. Switch off drive-ready state.
4. As applicable, connect the mode 2 charging cable to the domestic socket outlet or the

mode 3 charging cable to the connection point on the AC charging station.

5. Open the charging socket flap.
6. Connect the charging cable to the vehicle.
Connecting a charging cable, see page 319.
7. Lock the vehicle if necessary.

The charging cable is locked automatically once the charging cable connector has been inserted into the high-voltage charging socket.

Charging status display

Indicator light on the high-voltage charging socket



The charging status is indicated on the indicator light on the charging socket.

Charging status

Light	Meaning
White	Charging cable can be connected.
Yellow	Charging cable is locked.
Flashing yellow	Charging process is being prepared.
Blue	Charging process paused.
Flashing blue	Charging process is active.
Flashing red	Fault in charging process.
Green	Charging is complete.

If the vehicle is locked, the indicator light is extinguished after a while.

The blue indicator light flashes continuously while the vehicle is unlocked. The other indicator lights are extinguished after a while.

 Press the button on the vehicle key to check the charge state. The charge state is shown on the indicator light. The vehicle may be locked.

Additional messages about the charging status can be displayed in the instrument cluster or via the BMW app on a mobile device.

Setting the charging mode

1. "MENU"
2. "Vehicle apps"
3. "Charging"
4. "Charging mode"
5. Select the desired settings:
 - ▶ "Charge immediately": charging process starts as soon as the charging cable is connected.
 - ▶ "Charging in time slot": if a departure time is set, a time window with a cheaper electricity tariff can be set for charging.

Charging in the time window

General

During the charging process, a time window with a favourable electricity tariff can be set for charging.

The vehicle can also start the charging process before the selected time window begins or end it after the selected time window finishes. The starting point of the charging process is adjusted so the vehicle can be charged as much as possible and, if applicable, be air conditioned right up to the departure time.

Operating requirements

A departure time is defined.

Setting the time window for cost-effective charging

1. "MENU"
2. "Vehicle apps"
3. "Charging"
4. "Charging mode"
5. "Charging in time slot"
6. Select the desired setting.

Target charge

Principle

A percentage target value can be set when charging the high-voltage battery.

If a lower target value is set, the charging time can be shortened.

General

Charging with a set charging target is recommended in particular when charging the vehicle at a DC charging station.

To make optimum use of the function, a target value of 80 % is recommended.

Target values below 20 % cannot be set.

Setting the target charge

1. "MENU"
2. "Vehicle apps"
3. "Charging"
4. "Charging target"
5. Select the desired setting.

Permissible DC charging volume

If the vehicle is charged at a DC charging station, the noise emissions that occur during charging process can be restricted in order to comply with local noise regulations, for example. Restricting

the noise emissions may result in longer charging times.

1. "MENU"
2. "Vehicle apps"
3. "Charging"
4. "Fan loudness"
5. Select the desired setting.

Stopping charging process

When the vehicle is charged using a Mode 2 charging cable or a Mode 3 charging cable, the charging process will be interrupted when the vehicle is unlocked. The charging process will then be continued automatically after a short period of time or when the vehicle is locked.

The charging process can be terminated at any time by removing the charging cable, and resumed at a later point by connecting the charging cable. For example to allow other consumers to use the power supply in the meantime, or to avoid having several high power consumers connected at the same time.

For further information:

Removing, see page [320](#).

Resuming charging process

If charging is interrupted, for example, by unlocking the vehicle or due to a temporary power failure, the charging process will continue automatically after the interruption.

When the vehicle is charged at a public charging station, the charging process may not continue automatically after an interruption.

Ending charging process

1. Disconnect the charging cable from the vehicle.
Removing, see page [320](#).
2. Stow the charging cable if necessary.

- Press the charging socket flap closed until it engages.
- Lock the vehicle if necessary.

Goodbye screen on the control display





When the drive-ready state is turned off, a goodbye screen will appear on the control display where some of the settings for charging via iDrive can be entered.









Displays in the instrument cluster

When the standby state is switched on, the charging status display shows the charge state of the high-voltage battery in the instrument cluster. When all bars are filled, the high-voltage battery is fully charged.

Even if no bars are filled, the high-voltage system is always under high voltage.

The charge display displays information about the charging process.

Display	Meaning
	Charging the vehicle with a Mode 2 charging cable or Mode 3 charging cable.
	Charging the vehicle with a DC charging cable.
	Current charging power. + Icon indicates when the maximum charging capacity of the vehicle has been reached.
	Maximum charging current strength or currently set current limitation.
	Charging cable locked.

Display	Meaning
	Charging cable unlocked.
	Set charge target.
	Departure time set.
	One-time departure time set.
	Air conditioning activated for departure time.
	Flashing: ventilation or cooling active.
	Flashing: heating active.
	Yellow icon: charging capacity of the charging station is not available or restricted.



The hatched area indicates a limited charging capacity that can occur, for example, due to the connected charging infrastructure.

For further information:

Charge display, see page [155](#).

Departure time

Principle

For optimum range and climate control, the departure time can be set before parking the vehicle.

General

If settings for the air conditioning have been made, the vehicle is pre-conditioned for the set departure time.

The following settings for departure time are possible:

- ▷ Air conditioning for departure time.
- ▷ Scheduling of up to three regular departure times.
- ▷ Scheduling of a one-off departure time.

Air conditioning for departure time

1. "MENU"
2. "Vehicle apps"
3. "Charging"
4. "Departure plan"
5. "Pre-conditioning for departure"

Setting the departure time

1. "MENU"
2. "Vehicle apps"
3. "Charging"
4. "Departure plan"
5. Select the required departure time.
6. Set the time and day of the week.

Activating the departure time

1. "MENU"
2. "Vehicle apps"
3. "Charging"
4. "Departure plan"
5. Activate the required departure time.

The set departure time is deactivated if the departure time is not observed three times in succession.

Air conditioning

The following settings for air conditioning the vehicle are possible:

- ▷ Activate pre-conditioning immediately.
The range will be reduced if pre-conditioning is activated without a charging cable connected.
- ▷ Planned climate control at the set departure time.

For further information:

Pre-conditioning, see page [280](#).

Discharged high-voltage battery and vehicle battery

General

As well as the high-voltage battery, the vehicle has a 12-volt vehicle battery which is required for operating the on-board electronics.

It is not possible to operate the vehicle with a discharged vehicle battery.

Service life of the high-voltage battery

General

The high-voltage battery is maintenance-free.

More information regarding the high-voltage battery can be obtained from a Service Partner of the manufacturer or another qualified Service Partner or a specialist workshop.

Principle

The performance of the high-voltage battery decreases over its service life. The service life of the high-voltage battery can be optimised by one's own usage behaviour.

Charging instructions

For several consecutive DC charging processes, e.g. during a longer trip, the charging capacity is reduced, if necessary, temporarily, to protect the high-voltage battery.

With increased service life of the high-voltage battery, the charging capacity is also reduced.

To optimize the life of the high-voltage battery, observe the following:

- ▶ Preferably charge at AC charging stations for daily use.
- ▶ Keep the charge state between 10 % and 80 % where possible, for example by setting a charging target of 80 %. Charging target, see Charging process, see page [321](#).

Before and during travel

To optimize the life of the high-voltage battery, observe the following:

- ▶ Bring the high-voltage battery to operating temperature before driving. To do this, activate the vehicle's preliminary air conditioning. Setting the departure time, see page [325](#).
- ▶ Adopt an anticipatory driving style. Increasing the range, see page [309](#).

Parking

To optimize the life of the high-voltage battery, observe the following:

- ▶ Avoid direct sunlight at high outside temperatures.
- ▶ Park the vehicle in a protected area at low outside temperatures, for example in a garage.

Extended stationary periods

Before a longer stationary period, observe the following:

- ▶ If possible, park the vehicle with a charge level between 30 % and 50 %.
- ▶ Do not leave the charging cable connected.
- ▶ Do not place the vehicle in storage for longer than 14 days if the electric range has been used up.

Putting the vehicle out of use

A Service Partner of the manufacturer or another qualified Service Partner or a specialist workshop will be pleased to advise you on the measures that should be taken when placing the vehicle in storage for longer than three months.

Wheels and tyres

Vehicle equipment

This chapter describes equipment, systems and functions which are offered or will be offered on a model-specific basis, even if they are not included in the vehicle in question.

For further information:

Vehicle equipment, see page 7.

Tyre inflation pressure

General

The tyre condition and tyre inflation pressure influence the following:

- ▶ Tyre service life.
- ▶ Driving safety.
- ▶ Driving comfort.
- ▶ Energy consumption.

Safety note

WARNING

A tyre with too little or no tyre inflation pressure can heat up significantly and sustain damage. Handling characteristics, for example steering and braking, will be impaired as a result. There is a risk of accident. Check the tyre inflation pressure regularly and adjust as necessary, for example twice a month or before any long journey.

Tyre inflation pressure information

On the body pillar



The tyre inflation pressure information is located on the body pillar of the driver's door.

The tyre pressure applies to all tyre sizes and recommended tyre makes that have been rated by the vehicle manufacturer as suitable for the vehicle type concerned. The list can also include tyre sizes that are only suitable in combination with specific equipment.

Information about approved wheels and tyres for the vehicle can be requested from one of the manufacturer's Service Partners or another qualified Service Partner or specialist workshop.

The tyre inflation pressure appropriate for the respective load conditions should be used. For example, if the vehicle is partially loaded, use the tyre inflation pressure specified for a partially loaded vehicle.

For Australia/New Zealand

WARNING

The inflation pressures on the tyre label are applicable only for tyres explicitly mentioned on the label. Inflation pressures for tyres that may be covered by the label – by size, speed category and load rating/load index – but not explicitly mentioned on the label may be different. Please obtain adequate inflation pressures in

accordance with the tyre manufacturer's specifications from your tyre dealer.

On the control display

The current tyre inflation pressures and the specified tyre inflation pressures for the mounted tyres can be displayed on the control display.

To ensure that they are displayed correctly, the tyre sizes must be stored in the system and must have been set for the fitted tyres.

The current tyre inflation pressure value is shown on each tyre.

The specified tyre inflation pressure value is located towards the bottom of the control display.

Checking the tyre inflation pressure

General

Tyres heat up while driving. The tyre inflation pressure increases with the temperature of the tyre.

Tyres have a natural, uniform tyre pressure loss.

Inflating devices can display a pressure that may be up to 0.1 bar too low.

Checking using tyre inflation pressure information on the body pillar

1. Determine the specified tyre inflation pressures for the tyres installed on the vehicle.
2. Check the tyre inflation pressure in all four tyres, using a pressure gauge, for example.
3. Correct the tyre inflation pressure if the current tyre inflation pressure deviates from the specified tyre inflation pressure.
4. Check whether all valve caps are screwed onto the tyre valves.

The tyre inflation pressure information on the tyre pressure label on the body pillar only relates to cold tyres or tyres at the same temperature as the ambient temperature.

Only check the tyre inflation pressures when the tyres are cold, i.e.:

- ▶ If the vehicle has been driven a distance of no more than 2 km, 1.25 miles.
- ▶ If the vehicle has not moved again for at least 2 hours after a journey.

If equipped with an emergency tyre: check the tyre inflation pressure of the emergency wheel in the luggage compartment regularly and correct if necessary.

Checking using the tyre inflation pressure information on the control display

1. "MENU"
2. "Vehicle apps"
3. "Live Vehicle"
4. "Content"
5. "Vehicle status"
6. "Tyre Pressure Monitor"

After adjusting the tyre inflation pressure

For the flat tyre monitor RPA:

Reinitialise the flat tyre monitor RPA.

For the Tyre Pressure Monitor:

The corrected tyre inflation pressures are applied automatically. Make sure that the tyre settings are correct.

For tyres that are not listed in the tyre inflation pressure information on the control display, reset the Tyre Pressure Monitor.

Speed code letter

Designation	Maximum speed
Q	up to 160 km/h, 100 mph
R	up to 170 km/h, 106 mph
S	up to 180 km/h, 112 mph
T	up to 190 km/h, 118 mph
H	up to 210 km/h, 131 mph
F	up to 240 km/h, 150 mph

Designation	Maximum speed
W	up to 270 km/h, 167 mph
Y	up to 300 km/h, 186 mph
(Y)	above 300 km/h/186 mph

Tyre tread

Summer tyres

The tyre tread depth should not be less than 3 mm, 0.12 in, otherwise there is a high risk of aquaplaning.

Winter tyres

The tyre tread depth should not be less than 4 mm, 0.16 in, otherwise its suitability for winter use is restricted.

Minimum tread depth



Wear indicators are distributed around the circumference of the tyre. These wear indicators have the legally prescribed minimum height of 1.6 mm, 0.06 in.

The positions of the wear indicators are identified on the tyre sidewall by TWI, Tread Wear Indicator.

Tyre damages

General

Inspect tyres regularly for damage, the presence of foreign bodies and wear.

Vehicle behaviour that may indicate tyre damage or other faults:

- ▷ Unusual vibrations.
- ▷ Unusual tyre or running noises.
- ▷ Unusual vehicle response, such as pronounced pulling to the left or right.

Damage can be caused by the following situations, for example:

- ▷ Driving over kerbs.
- ▷ Road damage.
- ▷ Insufficient tyre inflation pressure.
- ▷ Overloading the vehicle.
- ▷ Incorrect tyre storage.

Safety notes

WARNING

If the tyres are damaged, the tyre inflation pressure may be reduced, which in turn could cause you to lose control of the vehicle. There is a risk of accident. If you suspect tyre damage while you are driving, immediately reduce speed and bring the vehicle to a stop. Have the wheels and tyres checked. To do so, carefully drive to a Service Partner of the manufacturer or another qualified Service Partner or a specialist workshop. If necessary, have the vehicle towed or transported there. Do not repair damaged tyres. Have them replaced.

WARNING

Tyres can become damaged by driving over obstacles, for example kerbs or damaged road surfaces, at high speed. Larger wheels have a smaller tyre cross-section. The smaller the tyre

cross-section, the higher the risk of tyre damage. There is a risk of accident and material damage. If possible, drive around obstacles or drive over them slowly and carefully.

Tyre age

Recommendation

Irrespective of the tyre tread depth, change tyres after 6 years at the latest.

Date of manufacture

The date of manufacture of the tyre is indicated on the tyre sidewall.

Designation	Date of manufacture
DOT ... 3821	38th week of 2021

Replacement of wheels and tyres

Fitting and balancing

Have the wheel fitted and balanced by a Service Partner of the manufacturer or another qualified Service Partner or a specialist workshop.

Permissible wheels and tyres

General

The following are recommended and approved by the manufacturer of the vehicle for the approved wheels and tyres per vehicle type and special equipment:

- ▶ Wheel and tyre combinations.
- ▶ Rim designs.
- ▶ Tyre sizes.
- ▶ Tyre makes.

You can ask a manufacturer Service Partner or another qualified Service Partner or specialist

workshop about the approved wheels and tyres for the vehicle and the special equipment.

Safety notes

WARNING

Wheels and tyres that are not suitable for the vehicle can damage parts of the vehicle. For example they could come into contact with the bodywork on account of their dimensional tolerances, despite having the same nominal size. There is a risk of accident. The manufacturer of the vehicle recommends using wheels and tyres that have been rated as suitable for the vehicle concerned.

WARNING

Mounted steel wheels can lead to technical problems, for example wheel bolts may work loose and brake discs may be damaged. There is a risk of accident. Do not install steel wheels.

WARNING

Incorrect wheel and tyre combinations will impair the vehicle's driving characteristics and a variety of system functions, for example the Anti-lock Braking System ABS or Dynamic Stability Control. There is a risk of accident. To maintain good vehicle handling, always fit tyres of the same make and tread pattern to all wheels. The manufacturer of the vehicle recommends using wheels and tyres that have been rated as suitable for the vehicle type concerned. After a tyre has been damaged, refit the same wheel/tyre combination as the original.

Recommended makes of tyre



Certain makes of tyre are recommended by the manufacturer of the vehicle for each tyre size. The tyre brands can be identified by a star on the tyre sidewall.

New tyres

Due to the manufacturing process, new tyres do not achieve their full road grip immediately. Drive moderately for the first 300 km, 200 miles.

Retreaded tyres

WARNING

Retreaded tyres may have different tyre carcasses. Their durability may be reduced due to their advanced age. There is a risk of accident. Do not use retreaded tyres.

The vehicle manufacturer advises against the use of retreaded tyres.

Winter tyres

General



Winter tyres are recommended if driving in winter conditions.

The winter tyres can be identified by the mountain and snowflake icon, as well as the M+S marking on the tyre sidewall.

Although tyres known as all-season tyres with M+S marking but without a mountain and snowflake icon have better winter characteristics than summer tyres, they do not normally match the performance of winter tyres.

Maximum speed of winter tyres

If the vehicle is capable of maximum speed higher than the speed permitted for the winter tyres, a sign stating the permitted maximum speed for the tyres fitted must be displayed in the driver's field of view. The sign is available from a Service Partner of the manufacturer or another qualified Service Partner or a specialist workshop.

If winter tyres are fitted, observe and do not exceed the relevant permitted maximum speed.

Replacing run-flat tyres

When changing from run-flat tyres to standard tyres, make sure that a emergency spare wheel or a flat tyre kit is available in the vehicle. Additional information is available from a Service Partner of the manufacturer or another qualified Service Partner or a specialist workshop.

Wheel change between axles

WARNING

Rotating wheels between axles on vehicles with differently sized tyres or rims on the front and rear may cause tyre damage and damage to the vehicle. There is a risk of accident. Do not rotate wheels between axles on vehicles with differently sized tyres or rims on the front and rear.

Depending on the individual operating conditions, the tyre tread wears differently on the front and rear wheels. To achieve even wear, the tyres can be swapped in pairs between the axles. Additional information is available from a Service Partner of the manufacturer or another qualified Service Partner or a specialist workshop. After swapping the wheels, check the tyre inflation pressure and adjust if necessary.

Storing tyres

Tyre inflation pressure

Do not exceed the maximum tyre inflation pressure indicated on the tyre sidewall.

Storage

- ▶ Store wheels and tyres in a cool, dry and dark place when not in use.
- ▶ Protect the tyres against contamination from oil, grease and solvents.
- ▶ Do not leave tyres in plastic bags.
- ▶ Remove dirt from the wheels or tyres.

Run-flat tyres

Principle

In the event of a complete tyre pressure loss, run-flat tyres enable you to continue driving, with certain restrictions.

General

The wheels are fitted with tyres which are self-supporting to a limited degree. They may also have special rims.

The reinforced sidewall means that the tyre keeps the vehicle mobile to a degree, even if tyre inflation pressure has been lost.

Observe the notes on continuing driving with a flat tyre.

Safety notes

WARNING

A run-flat tyre with too little or no tyre inflation pressure will change the vehicle's handling characteristics, for example there may be reduced directional stability when braking, longer braking distances and different self-steering characteristics. There is a risk of accident. Drive with care and do not exceed a speed of 80 km/h, 50 mph.

WARNING

Continuing to drive with a flat tyre can result in heavy trailers starting to slalom. There is a risk of accident or material damage. When driving with a trailer and a flat tyre, do not exceed the speed of 60 km/h, 35 mph. If the trailer starts to snake, brake immediately and make the necessary steering corrections as carefully as possible.

Identification



The tyres are identified by Runflat System Component RSC on the tyre sidewall.

Remedying flat tyre

Safety measures

- ▶ Park the vehicle on a firm surface and as far away from moving traffic as possible.
- ▶ Switch on the hazard warning lights.
- ▶ Apply the parking brake to prevent the vehicle rolling away.
- ▶ Engage the steering wheel lock with the wheels in the straight-ahead position.
- ▶ Have all vehicle occupants get out of the vehicle and guide them out of the danger area, for example behind the crash barrier.
- ▶ Where required, set up the warning triangle an appropriate distance away.

Tyre repair kit

Principle

With the tyre repair kit, minor tyre damage can be quickly sealed to allow the driver to continue driving.

General

- ▶ To allow the driver to continue driving, tyre sealant is pumped into the tyres which seals the damage from the inside when it hardens.
- ▶ Please observe the notes on using the tyre repair kit which are on the compressor and the tyre sealant bottle.
- ▶ The use of the tyre repair set can be ineffective in the event of tyre damage from a size of approx. 4 mm, approx. 0.16 in.
- ▶ Contact a Service Partner of the manufacturer or another qualified Service Partner or a specialist workshop if you are unable to put the tyre back in operation.
- ▶ Foreign bodies that have penetrated the tyre should remain inside the tyre. Only remove foreign objects if they are visibly protruding from the tyre.
- ▶ Remove the speed limit sticker from the tyre sealant bottle and attach to the steering wheel.
- ▶ Using tyre sealant can damage the wheel electronics. In this case, have the electronics replaced at the next opportunity.
- ▶ The compressor can be used to check the tyre inflation pressure.

Overview

Storage

Storage for the tyre repair set is provided in the storage under the luggage compartment floor.

Tyre sealant bottle

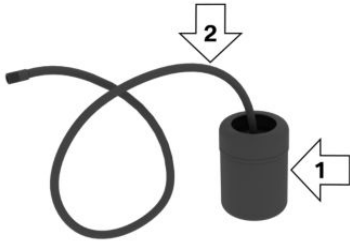

- ▷ Tyre sealant bottle, arrow 1.
- ▷ Filler hose, arrow 2.

Note the use-by date on the tyre sealant bottle.

Compressor

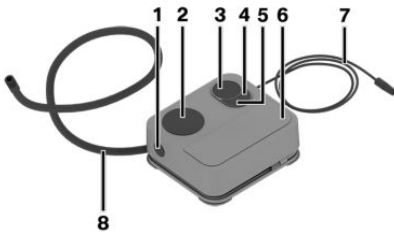

- 1 To unlock tyre sealant bottle
- 2 Tyre sealant bottle holder
- 3 Tyre inflation pressure indicator
- 4 Button for reducing the tyre inflation pressure
- 5 On/Off button
- 6 Compressor
- 7 Plug/cable for socket
- 8 Connecting hose

Safety measures

- ▷ Park the vehicle on a firm surface and as far away from moving traffic as possible.
- ▷ Switch on the hazard warning lights.
- ▷ Apply the parking brake to prevent the vehicle rolling away.

- ▷ Engage the steering wheel lock with the wheels in the straight-ahead position.
- ▷ Have all vehicle occupants get out of the vehicle and guide them out of the danger area, for example behind the crash barrier.
- ▷ Where required, set up the warning triangle an appropriate distance away.

Filling with tyre sealant

Safety note

NOTE

The compressor can overheat if operated for too long. There is a risk of material damage. Do not let the compressor run for longer than 10 minutes.

Filling

1. Shake the tyre sealant bottle.



2. Pull filler hose completely out of the cover of the tyre sealant bottle. Do not kink the hose.

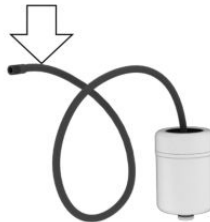

- Push the tyre sealant bottle into the holder on the compressor housing, until it audibly engages.

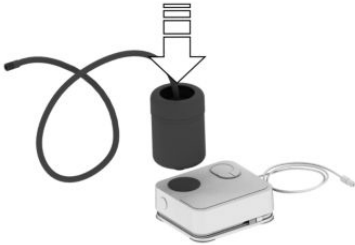

- Screw the filler hose of the tyre sealant bottle onto the tyre valve of the faulty wheel.



- With the compressor switched off, insert the plug into the socket inside the vehicle interior.



- Switch on the compressor with standby state or drive-ready state switched on.

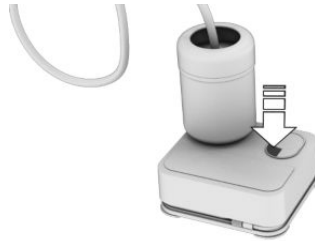

Let the compressor run for a maximum of 10 minutes to fill the tyre with sealant and achieve a tyre inflation pressure of approximately 2.0 bar.

The tyre inflation pressure may rise to approximately 5 bar during the filling process of the tyre sealant. Do not switch off the compressor during this step.

Checking and adjusting the tyre inflation pressure

Checking

- Switch off compressor.
- Read off the tyre inflation pressure as shown on the tyre pressure indicator.

To be able to continue the journey, a tyre inflation pressure of at least 2 bar must be reached.

Removing and storing the tyre sealant bottle

1. Unscrew the filler hose of the tyre sealant bottle from the tyre valve.
2. Press the red unlocking device.
3. Remove the tyre sealant bottle from the compressor.
4. Pack and store the tyre sealant bottle to avoid soiling the luggage compartment.

Minimum tyre inflation pressure is not reached

1. Remove the plug from the socket inside the vehicle interior.
2. Drive forwards and backwards by 10 m, 400 inches, to distribute the tyre sealant in the tyre.
3. Screw the connecting hose of the compressor directly onto the tyre valve.

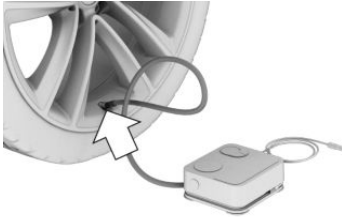

4. Insert the plug into the socket inside the vehicle interior.



5. With standby or drive-ready state turned on, turn on the compressor and let it run for a maximum of 10 minutes.

If the tyre inflation pressure of at least 2 bar is not reached, contact a Service Partner of the manufacturer or a qualified Service Partner or a specialist workshop.

If the tyre inflation pressure of at least 2 bar is reached, see Minimum tyre inflation pressure is reached.

6. Unscrew the connecting hose of the compressor from the tyre valve.
7. Remove the plug from the socket inside the vehicle interior.
8. Stow the tyre repair kit in the vehicle.

Minimum tyre inflation pressure is reached

1. Unscrew the connecting hose of the compressor from the tyre valve.
2. Remove the plug from the socket inside the vehicle interior.
3. Stow the tyre repair kit in the vehicle.
4. Immediately drive for approximately 10 km/5 mi to evenly distribute the tyre sealant in the tyre.

Do not exceed a speed of 80 km/h/50 mph.

If possible, do not drive slower than 20 km/h/12 mph.

Adjusting

1. Stop in a suitable area.
2. Screw the connecting hose of the compressor directly onto the tyre valve.

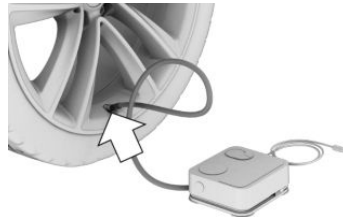

3. Insert the plug into the socket inside the vehicle interior.



4. Correct the tyre inflation pressure to at least 2.0 bar:
 - ▶ Increase tyre pressure: with standby or drive-ready state turned on, turn on the compressor and let it run for a maximum of 10 minutes.
 - ▶ To reduce tyre inflation pressure: press the button on the compressor.
5. Unscrew the connecting hose of the compressor from the tyre valve.
6. Remove the plug from the socket inside the vehicle interior.
7. Stow the tyre repair kit in the vehicle.

Resuming a journey

Do not exceed the permitted maximum speed of 80 km/h, 50 mph.

Reinitialise the flat tyre monitor RPA.

Reset the Tyre Pressure Monitor.

Have the punctured tyre and the tyre sealant bottle of the tyre repair kit replaced as soon as possible.

For further information:

- ▶ Flat tyre monitor RPA, see page [345](#).
- ▶ Tyre Pressure Monitor, see page [338](#).

Snow chains

Safety notes

WARNING

If snow chains are fitted to unsuitable tyres, the snow chains can come into contact with parts of the vehicle. There is a risk of accident or material damage. Only fit snow chains on tyres which have been approved by the manufacturer as being suitable for snow chains.

WARNING

Insufficiently tensioned snow chains can damage tyres and vehicle components. There is a risk of accident or material damage. Ensure that snow chains are always adequately tensioned. Re-tension them if necessary in accordance with the snow chain manufacturer's instructions.

Fine-link snow chains

The vehicle manufacturer recommends using fine-link snow chains. Certain fine-link snow chains have been tested, found safe for use in traffic and rated as suitable by the manufacturer of the vehicle.

Information regarding suitable snow chains is available from a Service Partner of the manufacturer or another qualified Service Partner or a specialist workshop.

Use

Use only in pairs on the rear wheels, equipped with the tyres of the following wheel/tyre sizes:

Tyre size	Wheel size	Rim offset (IS)
225/55 R17	7.5J x 17	30
245/45 R18	8.5J x 18	36

The information on the wheel size and rim offset is located on the inside of the wheel.

The list can also include wheel/tyre sizes that are only suitable for certain models.

Information about approved wheels and tyres for the vehicle can be requested from one of the manufacturer's Service Partners or another qualified Service Partner or specialist workshop.

Observe the snow chain manufacturer's instructions.

Do not initialise the flat tyre monitor (RPA) with snow chains fitted, as it may give incorrect readings.

Do not reset the Tyre Pressure Monitor with snow chains fitted, as it may give incorrect readings.

When driving with snow chains fitted, activate Dynamic Traction Control DTC briefly as required in order to optimise drive.

Maximum speed with snow chains

When snow chains are fitted, do not exceed 50 km/h, 30 mph.

Tyre Pressure Monitor

Principle

The Tyre Pressure Monitor monitors the tyre pressure and issues a warning if the tyre pressure has dropped.

General

Sensors in the tyre valves measure the tyre inflation pressure and tyre air temperature.

Depending on the tyres detected or entered, the system displays the specified nominal pressures on the control display and compares them to the current tyre inflation pressures.

If the vehicle is fitted with tyres which are not listed in the tyre inflation pressure information on the vehicle, for example tyres with special approval, the system must be actively reset. The cur-

rent tyre inflation pressures are then accepted as the nominal pressures.

When operating the system, please also comply with the information and notes in the chapter on tyre inflation pressure.

For further information:

Tyre inflation pressure, see page [327](#).

Safety note

WARNING

The display showing the specified tyre inflation pressures does not replace the tyre inflation pressure information on the vehicle. If incorrect data has been entered into the tyre settings, the specified tyre inflation pressures will also be incorrect. As a result, reliable signalling of a loss of tyre inflation pressure can no longer be guaranteed. There is a risk of injury and material damage. Make sure that the tyre sizes of the fitted tyres are displayed correctly and that they match the specifications on the tyres and in the tyre inflation pressure information.

Operating requirements

The following requirements must be met for the system, otherwise reliable message of a tyre pressure loss is not ensured:

- ▶ After each tyre or wheel change, the system has detected the fitted tyres, updated the relevant information and, after a short journey, shown it on the control display.

If the system does not detect the tyres automatically, enter the specifications for the fitted tyres in the tyre settings.

- ▶ The Tyre Pressure Monitor only becomes active after driving for several minutes:
 - ▶ After tyre/wheel change.
 - ▶ After a reset, For tyres with special approval.
 - ▶ After changing the tyre setting.

- ▶ For tyres with special approval:
 - ▶ After every tyre or wheel change, the system must be reset once the tyre inflation pressure is correct.
 - ▶ A reset must be carried out after the tyre inflation pressure has been adjusted to a new value.
- ▶ Wheels with wheel electronics.

Tyre settings

General

If the system does not detect the tyres automatically, the specifications for the fitted tyres can be entered in the tyre settings.

The tyre sizes of the fitted tyres can be found in the tyre inflation pressure information on the vehicle or directly on the tyres.

The tyre data does not have to be re-entered if the tyre inflation pressure is corrected.

For summer and winter tyres, the tyre data last entered for each type is saved. This means that the settings can be selected again after a tyre or wheel change.

Adjusting the settings

1. "MENU"
2. "Vehicle apps"
3. "Live Vehicle"
4. "Content"
5. "Vehicle status"
6. "Tyre Pressure Monitor"
7. "Tyre settings"
8. "Tyre selection"
9. "Manual"
10. "Tyre type"
11. Select the tyre type mounted on the rear axle.
 - For tyres with special approval:
 - "Other tyres"

See the Performing a reset section for how to proceed.

12. Select the load status of the vehicle once tyre size has been selected.

13. "Save tyre settings"

The measurement of the current tyre inflation pressure is started. The progress of the measurement is shown.

Status display

Current status

The status of the system, for example whether the system is active, can be shown on the control display.

1. "MENU"
2. "Vehicle apps"
3. "Live Vehicle"
4. "Content"
5. "Vehicle status"
6. "Tyre Pressure Monitor"

The current status is displayed.

Current tyre inflation pressure

The current tyre inflation pressure is displayed for each tyre.

The current tyre inflation pressures can vary depending on vehicle operation or outside temperature.

Current tyre air temperature

Depending on the model, the current tyre air temperatures are shown.

The current tyre air temperatures can change as a result of vehicle operation or the outside temperature.

Nominal pressure

The nominal pressure for the tyres on the front and rear axle is displayed.

The stated nominal pressure takes account of the temperature effects caused by vehicle operation and the outside temperature. The appropriate nominal pressure is always displayed irrespective of the weather conditions, tyre air temperatures and length of journey.

The displayed nominal pressure may vary and differ from the value stated in the tyre inflation pressure information on the body pillar of the driver's door. The tyre inflation pressure can thus be corrected to the value of the displayed nominal pressures.

The nominal pressure is adjusted immediately if the load status is changed in the tyre settings.

Tyre statuses

General

The status of the system and tyres is indicated by the wheel colour and a message on the control display.

Existing messages may not be deleted if the nominal pressure is not reached when the tyre inflation pressure is corrected.

All wheels green

- ▶ The system is active and refers to the nominal pressures for the warning.
- ▶ For tyres with special approval: the system is active and is using the tyre inflation pressures saved during the last reset for the warning.

One to four wheels yellow

There is a flat tyre or major tyre pressure loss in the tyres shown.

Wheels grey

Tyre pressure losses might not be detected.

Possible causes:

- ▶ Malfunction.
- ▶ The tyre inflation pressure is being measured, after confirmation of the tyre settings.
- ▶ For tyres with special approval: a system reset is being performed.

For tyres with special approval: performing a reset

1. "MENU"
2. "Vehicle apps"
3. "Live Vehicle"
4. "Content"
5. "Vehicle status"
6. "Tyre Pressure Monitor"
7. Make sure that the tyre settings are correct. Tyre settings, see page 339.
8. Switch on drive-ready state but do not drive off.
9. Reset the tyre inflation pressure: "Perform reset"
10. Drive off.

The wheels are shown grey and the following appears on the display: "Resetting tyre pressure...".

After driving for several minutes, the set tyre inflation pressures are accepted as the specified tyre inflation pressures. The reset is completed automatically during the journey.

If the reset was successful, the wheels are shown in green on the control display and the following appears: "Reset successful."

You can interrupt your journey at any time. The reset resumes automatically when you continue driving.

Messages: for tyres without special approval

General

When a low tyre pressure is indicated, the Dynamic Stability Control may be turned on.

Safety note

WARNING

A damaged standard tyre with too little or no tyre inflation pressure impairs driving characteristics, for example steering and braking. Tyres with run-flat properties allow a limited level of stability to be maintained. There is a risk of accident. Do not continue driving if the vehicle is fitted with standard tyres. Comply with the notes on run-flat tyres and continuing a journey with these tyres.

If a tyre inflation pressure check is required

Message

An icon with a Check Control message is shown on the control display.

Icon	Possible cause
	The tyre was not inflated properly, for example insufficient air was added or there was a natural, even tyre pressure loss.



The tyre was not inflated properly, for example insufficient air was added or there was a natural, even tyre pressure loss.

Action

Check the tyre inflation pressure and adjust as necessary.

If the tyre inflation pressure is too low

Message



A yellow warning light is illuminated in the instrument cluster.

In addition, an icon with a Check Control message is shown on the control display.

Icon	Possible cause
	There has been a tyre pressure loss.



There has been a tyre pressure loss.

Action

1. Reduce speed. Do not exceed a speed of 130 km/h, 80 mph.
2. At the next opportunity, for example at a filling station, check the tyre inflation pressure in all four tyres and correct if necessary.

If there is a significant tyre pressure loss

Message



A yellow warning light is illuminated in the instrument cluster.

In addition, an icon indicating which tyre is affected is shown in a Check Control message on the control display.

Icon	Possible cause
	There is a flat tyre or substantial tyre pressure loss.



There is a flat tyre or substantial tyre pressure loss.

Action

1. Reduce your speed and carefully stop the vehicle. Avoid heavy braking and sudden steering manoeuvres.
2. Check whether the vehicle is equipped with standard tyres or run-flat tyres.
The icon identifying run-flat tyres is a circle with the letters RSC on the tyre sidewall.
Run-flat tyres, see page 332.
3. Follow the description of what to do when the vehicle gets a flat tyre.

What to do in the event of a flat tyre, see page 343.

Messages: for tyres with special approval

General

When a low tyre pressure is indicated, the Dynamic Stability Control may be turned on.

Safety note

WARNING

A damaged standard tyre with too little or no tyre inflation pressure impairs driving characteristics, for example steering and braking. Tyres with run-flat properties allow a limited level of stability to be maintained. There is a risk of accident. Do not continue driving if the vehicle is fitted with standard tyres. Comply with the notes on run-flat tyres and continuing a journey with these tyres.

If a tyre inflation pressure check is required

Message

An icon with a Check Control message is shown on the control display.

Icon	Possible cause
------	----------------



The tyre was not inflated properly, for example insufficient air was added.

The system has detected a wheel change, but no reset has been performed.

The tyre inflation pressure has dropped compared to the last reset.

No reset has been performed on the system. System warning is based on the tyre inflation pressures saved during the last reset.

Action

1. Check the tyre inflation pressure and adjust as necessary.
2. Perform a system reset.

If the tyre inflation pressure is too low

Message



A yellow warning light is illuminated in the instrument cluster.

In addition, an icon with a Check Control message is shown on the control display.

Icon	Possible cause
------	----------------



There has been a tyre pressure loss.

No reset has been performed on the system. System warning is based on the tyre inflation pressures saved during the last reset.

Action

1. Reduce speed. Do not exceed a speed of 130 km/h, 80 mph.
2. At the next opportunity, for example at a filling station, check the tyre inflation pressure in all four tyres and correct if necessary.
3. Perform a system reset.

If there is a significant tyre pressure loss

Message



A yellow warning light is illuminated in the instrument cluster.

In addition, an icon indicating which tyre is affected is shown in a Check Control message on the control display.

Icon	Possible cause
------	----------------



There is a flat tyre or substantial tyre pressure loss.

No reset has been performed on the system. System warning is based on the tyre inflation pressures saved during the last reset.

Action

1. Reduce your speed and carefully stop the vehicle. Avoid heavy braking and sudden steering manoeuvres.
2. Check whether the vehicle is equipped with standard tyres or run-flat tyres.
The icon identifying run-flat tyres is a circle with the letters RSC on the tyre sidewall.
Run-flat tyres, see page 332.
3. Follow the description of what to do when the vehicle gets a flat tyre.
What to do in the event of a flat tyre, see page 343.

What to do in the event of a flat tyre

Standard tyres

1. Identify the damaged tyre.
Check the tyre inflation pressure in all four tyres, for example using the tyre inflation pressure indicator of a tyre repair kit.
For tyres with special approval: if all four tyres are inflated to the correct tyre inflation pressures, the Tyre Pressure Monitor might not have been reset. Perform a reset.
If no tyre damage can be found, contact a Service Partner of the manufacturer or another qualified Service Partner or a specialist workshop.
2. Repair the flat tyre, for example using a tyre repair kit or by changing the wheel.
The use of tyre sealant, for example a flat tyre kit, can damage the wheel electronics. Have the electronics replaced at the next opportunity.

Run-flat tyres

Safety notes

 **WARNING**

A run-flat tyre with too little or no tyre inflation pressure will change the vehicle's handling characteristics, for example there may be reduced directional stability when braking, longer braking distances and different self-steering characteristics. There is a risk of accident. Drive with care and do not exceed a speed of 80 km/h, 50 mph.

 **WARNING**

Continuing to drive with a flat tyre can result in heavy trailers starting to slalom. There is a risk of accident or material damage. When driving with a trailer and a flat tyre, do not exceed the speed of 60 km/h, 35 mph. If the trailer starts to snake, brake immediately and make the necessary steering corrections as carefully as possible.

Maximum speed

If a tyre is damaged you can continue driving, but do not exceed a maximum speed of 80 km/h, 50 mph.

Continuing driving with a flat tyre

Observe the following if you continue driving with a flat tyre:

1. Avoid heavy braking and sudden steering manoeuvres.
2. Do not exceed a speed of 80 km/h, 50 mph.
3. At the next opportunity, check the tyre inflation pressure in all four tyres.

Possible driving distance with a deflated tyre

The possible driving distance varies depending on the load and stresses the vehicle is subjected

to, for example speed, the nature of the road surface, outside temperature. The driving distance may be shorter but can be increased if a careful driving style is adopted.

With moderate loads and low stress, it is possible to travel up to 80 km, 50 miles.

Driving properties with damaged tyres

Driving with damaged tyres changes the vehicle's handling characteristics and may lead to situations such as the following:

- ▶ The vehicle losing traction more quickly.
- ▶ Longer stopping distances.
- ▶ Different self-steering properties.

Adapt your driving style. Avoid abrupt steering or driving over obstacles, for example kerbs or pot-holes.

Final tyre failure

Vibration or loud noises during the journey may be an indication that the tyre has finally failed.

Reduce your speed and stop the vehicle. Parts of the tyre may detach, which might lead to an accident.

Do not continue driving, but instead contact a Service Partner of the manufacturer or another qualified Service Partner or a specialist workshop.

System limits

Temperature

The tyre inflation pressure depends on the temperature of the tyre.

The tyre inflation pressure increases as the tyre air temperature increases, for example while driving or when exposed to sunlight.

The tyre inflation pressure decreases when the tyre air temperature drops.

Due to the system's inherent warning thresholds, therefore, this behaviour may cause a warning to be triggered when significant temperature drops occur.

After a temperature-related warning, the nominal pressures are displayed again on the control display after driving a short distance.

Sudden tyre pressure loss

No warning can be given in the event of extreme, sudden tyre damages caused by external factors.

Reset not carried out

Tyres with special approval: the system will not function correctly if a reset has not been carried out, for example, a flat tyre may be reported even though the tyre pressure is correct.

Malfunition

Message



The yellow warning light flashes and then illuminates continuously. A Check Control message is shown. Tyre pressure losses may not be detected.

Action

- ▶ A wheel without wheel electronics is mounted: have the wheels checked if necessary.
- ▶ Fault due to systems or devices with the same radio frequency: the system is automatically reactivated upon leaving the field of interference.
- ▶ For tyres with special approval: the system was unable to complete the reset. Perform a system reset again.
- ▶ Tyre Pressure Monitor malfunction: have the system checked by a Service Partner of the manufacturer or another qualified Service Partner or specialist workshop.

Flat tyre monitor RPA

Principle

The flat tyre monitor detects a tyre pressure loss while driving and issues a warning if the tyre pressure has dropped.

General

The system identifies a tyre pressure loss by comparing the rotational speeds of the individual wheels during the journey.

A tyre pressure loss changes the diameter, and with it the rotational speed, of the corresponding wheel. The discrepancy is detected and reported as a flat tyre.

The system does not measure the tyre inflation pressure as such.

Operating requirements

The following requirements must be met for the system, otherwise reliable message of a tyre pressure loss is not ensured:

- ▶ After every tyre or wheel change, the system must be initialised once the tyre inflation pressure is correct.
- ▶ The system must be initialised after the tyre inflation pressure is adjusted to a new value.

Status display

It is possible to display the current status of the flat tyre monitor RPA, for example to check whether the RPA is active.

1. "MENU"
2. "Vehicle apps"
3. "Live Vehicle"
4. "Content"
5. "Vehicle status"
6. "Flat Tyre Monitor"

The status is displayed.

Initialisation required

An initialisation must be performed in the following situations:

- ▶ After adjusting the tyre inflation pressure.
- ▶ After tyre/wheel change.

Initialisation

Initialisation saves the set tyre inflation pressures as reference values for subsequent detection of a flat tyre. Initialisation is started by confirming the correct tyre inflation pressures.

Do not initialise the system if driving with snow chains fitted.

1. "MENU"
2. "Vehicle apps"
3. "Live Vehicle"
4. "Content"
5. "Vehicle status"
6. "Flat Tyre Monitor"
7. Switch on drive-ready state but do not drive off.
8. Start the initialisation: "Perform reset"
9. Drive off.

Initialisation is completed during the journey which can be interrupted at any time.

Initialisation resumes automatically when you continue driving.

Messages

General

When a flat tyre is indicated, the Dynamic Stability Control is turned on, if needed.

Safety note

WARNING

A damaged standard tyre with too little or no tyre inflation pressure impairs driving characteristics, for example steering and braking. Tyres with run-flat properties allow a limited level of stability to be maintained. There is a risk of accident. Do not continue driving if the vehicle is fitted with standard tyres. Comply with the notes on run-flat tyres and continuing a journey with these tyres.

Flat tyre message



A yellow warning light is illuminated in the instrument cluster.

In addition, an icon with a Check Control message is shown on the control display.

Icon	Possible cause
	There is a flat tyre or substantial tyre pressure loss.

Action

1. Reduce your speed and carefully stop the vehicle. Avoid heavy braking and sudden steering manoeuvres.
2. Check whether the vehicle is equipped with standard tyres or run-flat tyres.
The icon identifying run-flat tyres is a circle with the letters RSC on the tyre sidewall.
Run-flat tyres, see page 332.
3. Follow the description of what to do when the vehicle gets a flat tyre.

What to do in the event of a flat tyre

Standard tyres

1. Identify the damaged tyre.

To do this, check the tyre inflation pressure in all four tyres, for example using the tyre inflation pressure indicator of a tyre repair kit.

If all four tyres are inflated to the correct tyre inflation pressures, the flat tyre monitor (RPA) might not have been initialised. In this case initialise the system.

If no tyre damage can be found, contact a Service Partner of the manufacturer or another qualified Service Partner or a specialist workshop.

2. Repair the flat tyre, for example using a tyre repair kit or by changing the wheel.

Run-flat tyres

Safety notes

WARNING

A run-flat tyre with too little or no tyre inflation pressure will change the vehicle's handling characteristics, for example there may be reduced directional stability when braking, longer braking distances and different self-steering characteristics. There is a risk of accident. Drive with care and do not exceed a speed of 80 km/h, 50 mph.

WARNING

Continuing to drive with a flat tyre can result in heavy trailers starting to slalom. There is a risk of accident or material damage. When driving with a trailer and a flat tyre, do not exceed the speed of 60 km/h, 35 mph. If the trailer starts to snake, brake immediately and make the necessary steering corrections as carefully as possible.

Maximum speed

If a tyre is damaged you can continue driving, but do not exceed a maximum speed of 80 km/h, 50 mph.

Continuing driving with a flat tyre

Observe the following if you continue driving with a flat tyre:

1. Avoid heavy braking and sudden steering manoeuvres.
2. Do not exceed a speed of 80 km/h, 50 mph.
3. At the next opportunity, check the tyre inflation pressure in all four tyres.

If all four tyres are inflated to the correct tyre inflation pressures, the flat tyre monitor might not have been initialised. In this case initialise the system.

Possible driving distance with a deflated tyre

The possible driving distance varies depending on the load and stresses the vehicle is subjected to, for example speed, the nature of the road surface, outside temperature. The driving distance may be shorter but can be increased if a careful driving style is adopted.

With moderate loads and low stress, it is possible to travel up to 80 km, 50 miles.

Driving properties with damaged tyres

Driving with damaged tyres changes the vehicle's handling characteristics and may lead to situations such as the following:

- ▶ The vehicle losing traction more quickly.
- ▶ Longer stopping distances.
- ▶ Different self-steering properties.

Adapt your driving style. Avoid abrupt steering or driving over obstacles, for example kerbs or potholes.

Final tyre failure

Vibration or loud noises during the journey may be an indication that the tyre has finally failed.

Reduce your speed and stop the vehicle. Parts of the tyre may detach, which might lead to an accident.

Do not continue driving, but instead contact a Service Partner of the manufacturer or another

qualified Service Partner or a specialist workshop.

System limits

In the following situations, the system could be slow to respond or could work incorrectly:

- ▶ A natural, even tyre pressure loss in all four tyres that occurs over time will not be detected. Therefore check the tyre inflation pressure at regular intervals.
- ▶ No warning can be given in the event of sudden tyre damages caused by external factors.
- ▶ The system has not been initialised.
- ▶ When driving on snow-covered or slippery roads.
- ▶ Dynamic driving style: drive wheels slipping, high lateral acceleration.
- ▶ When driving with snow chains.

Wheel change

General

For run-flat tyres or when using a tyre repair kit, it is not always necessary to change a wheel immediately if tyre inflation pressure is lost due to a flat tyre.

If required, the tools for wheel change are available as optional accessories from a Service Partner of the manufacturer, another qualified Service Partner or a specialist workshop.

Safety notes

WARNING

The jack is only intended for raising the vehicle briefly during a wheel change. Even if the safety measures are complied with, there is a risk of the raised vehicle falling over due to the jack slipping. There is a danger of injury or danger to life. If the vehicle is raised with the jack, do not

lie underneath the vehicle and do not switch on drive-ready state.

WARNING

Supports such as wooden blocks under the jack can prevent it from achieving its load capacity due to the restricted height. The load capacity of the wooden blocks may be exceeded, causing the vehicle to tip over. There is a danger of injury or danger to life. Do not place supports under the jack.

WARNING

The jack, issued by the vehicle manufacturer, is provided in order to perform a wheel change in the event of a breakdown. The jack is not designed for frequent use; for example, changing from summer to winter tyres. Using the jack frequently may cause it to become jammed or damaged. There is a risk of injury and material damage. Only use the jack to change an emergency wheel or a spare wheel when the vehicle gets a flat tyre.

WARNING

On soft, uneven or slippery ground, for example snow, ice, tiles or similar, the jack may slip. There is a danger of injury. Perform the wheel change on a level, firm and non-slip surface if at all possible.

WARNING

The jack is only optimised for raising the vehicle and for use with the jacking points on the vehicle. There is a danger of injury. Do not lift another vehicle or other items with the jack.

WARNING

If the jack has not been guided into the jacking point provided, the vehicle might be damaged when the jack is extended, or the jack could slip. There is a risk of injury or material damage. When extending, make sure that the jack is guided into the jacking point adjacent to the wheel arch.

WARNING

A vehicle raised with a jack can fall from the jack if lateral forces are applied. There is a risk of injury and material damage. If the vehicle is raised, do not apply any lateral forces to the vehicle or pull the vehicle with sudden movements. Have any wheel that is jammed removed by a Service Partner of the manufacturer or another qualified Service Partner or a specialist workshop.

WARNING

The jack can damage the base of the vehicle if operated incorrectly, thereby exposing high-voltage components. There is a risk of injury or material damage. When extending, make sure that the jack is guided into the jacking point adjacent to the wheel arch. Ensure that no parts of the underbody trim are damaged.

Securing the vehicle against rolling away

General

The vehicle manufacturer recommends that the vehicle should additionally be protected against rolling away during a wheel change.

On a level surface



Place chocks or other suitable objects in front of and behind the wheel diagonally opposite to the one being changed.

On a slight downhill gradient



If it is necessary to change a wheel on a slight downhill gradient, place chocks and other suitable objects, for example stones, under the wheels of the front and rear axles against the direction of roll.

Locking wheel bolts

Principle

The locking wheel bolts have a special coding. The bolts can only be released with the adapter that matches the coding.

Overview

The adapter of the locking wheel bolts can be found in the on-board tool kit or in an oddments tray in the on-board tool kit.

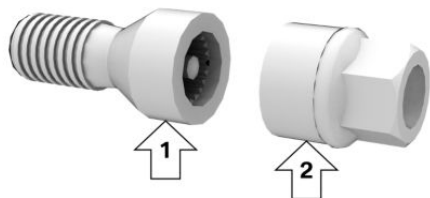

- ▷ Locking wheel bolt, arrow 1.
- ▷ Adapter, arrow 2.

Unscrewing

1. Place the adapter on the locking wheel bolt.
2. Unscrew the locking wheel bolt.
3. After unscrewing the wheel stud, remove the adapter again.

Screwing on

1. Place the adapter on the locking wheel bolt. If necessary, turn the adapter until it fits on the locking wheel bolt.
2. Screw on the locking wheel bolt. The tightening torque is 140 Nm, 101 lb ft.
3. After screwing on the wheel bolt, remove the adapter again and stow it.

Preparing the vehicle

- ▷ Park the vehicle on firm and non-slip ground at a safe distance from traffic.
- ▷ Switch on the hazard warning lights.
- ▷ Apply the parking brake.
- ▷ Engage a gear or select selector lever position P.
- ▷ As soon as the traffic flow permits, have all vehicle occupants get out of the vehicle and guide them out of the danger area, for example behind the crash barrier.
- ▷ Depending on the equipment, take the tools for changing wheels and, if necessary, the emergency spare wheel out of the vehicle.

- ▶ If applicable, set up warning triangle or flashing light at the correct distance.
- ▶ Additionally protect the vehicle against rolling away.
- ▶ Undo the wheel bolts by half a turn.

Jacking points

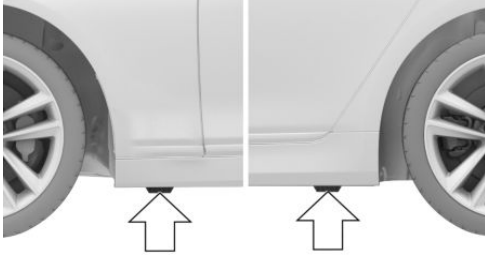

The jacking points are located in the marked positions.

Raising vehicle

WARNING

Your hands or fingers could get trapped when using the jack. There is a danger of injury. Keep your hands in the described position when using the jack, and do not change this position.

1. Hold the jack with one hand, arrow 1, and grasp the jack crank or lever with your other hand, arrow 2.

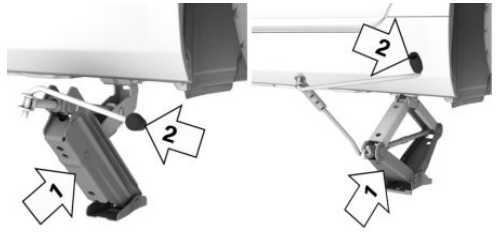

2. Guide the jack into the rectangular recess of the jacking point closest to the wheel to be changed.

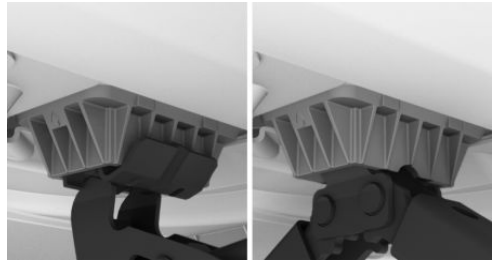

3. Turn the jack crank or lever clockwise to extend the jack.



4. Remove your hand from the jack as soon as the jack is under load and continue to turn the jack crank or lever with one hand.

5. Make sure that the base of the vehicle jack is extended vertically and at right angles underneath the jacking point.

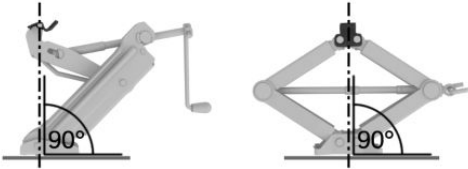

6. Make sure that the base of the jack is vertical and at right angles below the jacking point after extension.

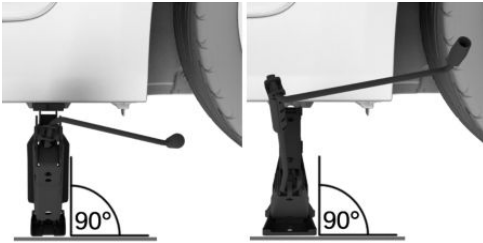

7. Raise by cranking until the jack is supported on the ground with its entire surface and the wheel in question is a maximum of 3 cm, 1.2 inches off the ground.

Fitting a wheel

No more than one emergency spare wheel may be fitted.

1. Unscrew the wheel bolts.
2. Remove the wheel.
3. Put on the new wheel or emergency spare wheel and tighten at least two wheel bolts crosswise until finger-tight.

If installing non-original light alloy wheels not supplied by the manufacturer, the wheel bolts belonging to the wheels may also have to be used.

4. Tighten the remaining wheel bolts until finger-tight and then tighten all the wheel bolts crosswise.
5. Turn the jack crank handle anticlockwise to retract the jack and lower the vehicle.
6. Remove the jack and stow it securely.

After wheel change

1. Tighten the wheel bolts crosswise. The tightening torque is 140 Nm, 101 lb ft.
2. Stow the faulty wheel in the luggage compartment, if necessary.
3. Check tyre inflation pressure at the next opportunity and correct as necessary.
4. Re-initialise the flat tyre monitor or reset the Tyre Pressure Monitor.
5. Check the tight fit of the wheel bolts using a calibrated torque wrench.
6. Drive to the nearest Service Partner of the manufacturer or another qualified Service Partner or a specialist workshop to have the damaged tyre replaced.

Under the bonnet

Overview

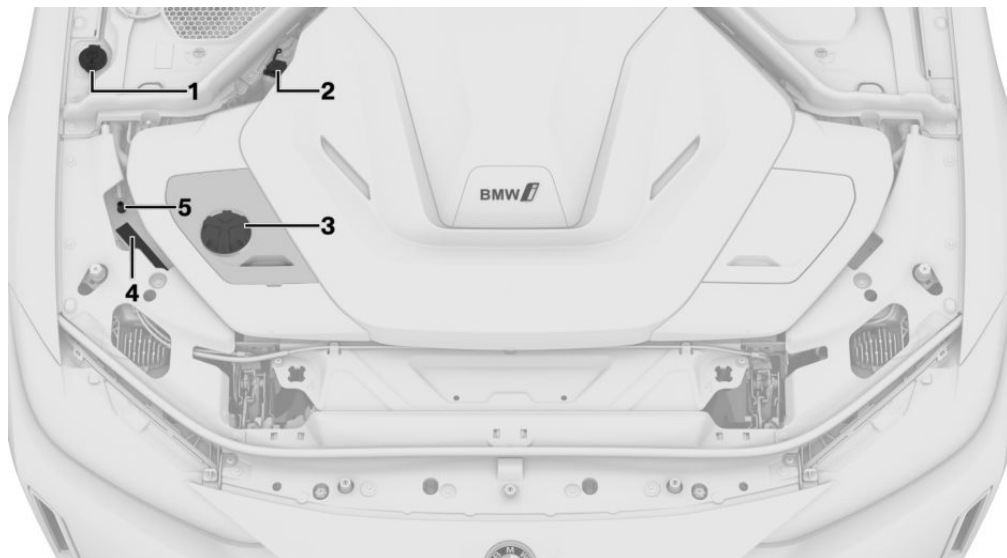

- | | |
|--|---|
| <p>1 Filler neck for washer fluid</p> <p>2 Jump start, positive battery terminal</p> <p>3 Coolant</p> | <p>4 Vehicle identification number</p> <p>5 Jump start, negative battery terminal</p> |
|--|---|

Bonnet

Safety notes

⚠ WARNING

If the bonnet is not correctly locked, it can come open during the journey and impair visibility. There is a risk of accident. Stop immediately and close the bonnet correctly.

⚠ WARNING

Parts of the body can become trapped when opening and closing the bonnet. There is a danger of injury. When opening and closing, make sure that the area of movement of the bonnet is kept clear.

⚠ WARNING

Work performed incorrectly under the bonnet can damage components and lead to a safety risk. There is a risk of accident or material damage. Have work under the bonnet carried out by a Service Partner of the manufacturer or an

other qualified Service Partner or a specialist workshop.

⚠ WARNING

The front flap has protruding parts on the inside, for example locking hooks. There is a danger of injury. When the front flap is open, watch out for protruding parts and keep these areas clear.

⚠ WARNING

The front flap contains moving components. Certain components under the front flap can also move when the vehicle is switched off, for example the radiator fan. There is a danger of injury. Do not reach into an area where there are moving parts. Keep articles of clothing and hair away from moving parts.

⚠ NOTE

Wipers which are folded away from the windscreen can become trapped if the front flap is opened. There is a risk of material damage. Before opening the bonnet, make sure that the wipers are fitted with wiper blades and are in contact with the windscreen.

⚠ NOTE

When closing, the front flap must lock into place on both sides. Applying additional pressure can damage the front flap. There is a risk of material damage. Open the front flap again and close it firmly. Avoid applying additional pressure.

Opening bonnet

1. Pull the lever, arrow 1. The bonnet is unlocked.



2. After releasing the lever, pull the lever again, arrow 2. The bonnet can be opened.
3. Watch out for any protruding parts on the bonnet.

Closing the bonnet

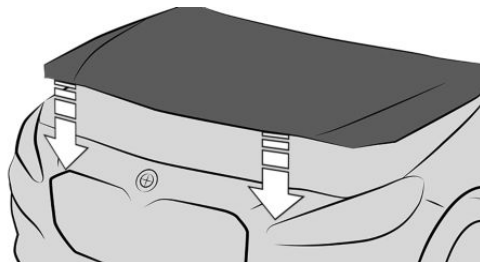

Allow the bonnet to drop from a height of approximately 50 cm, approx. 20 in.

The bonnet must engage on both sides.

Operating fluids

Vehicle equipment

This chapter describes equipment, systems and functions which are offered or will be offered on a model-specific basis, even if they are not included in the vehicle in question.

For further information:

Vehicle equipment, see page 7.

Coolant

General

Coolant is a mixture of water and coolant additive.

Not all commercially available additives are suitable for the vehicle. The vehicle manufacturer recommends using coolant with the BMW LC-18 specification. Do not mix additives of different colours. Comply with the 50:50 mixing ratio of water to additive. Information regarding suitable additives is available from a Service Partner of the manufacturer or another qualified Service Partner or a specialist workshop.

Safety notes

WARNING

If the cooling system is opened when the drivetrain is hot, coolant can escape and cause scalding. There is a danger of injury. Only open the cooling system when the drivetrain has cooled down.

WARNING

Additives are harmful to health and using the wrong additives can damage the drivetrain. There is a danger of injury and material damage. Do not allow additives to come into contact with clothing, skin or eyes, and do not swallow them. Only use suitable additives.

Coolant level

General

The coolant tank is located on the right side under the bonnet.

On factory delivery, the coolant may be overfilled in the coolant tank. The normal level of the coolant level is achieved by prolonging the operating time.

The target coolant level is indicated by means of the max. mark in the coolant filler neck of the coolant tank.

Have coolant topped up by a Service Partner of the manufacturer or another qualified Service Partner or specialist workshop.

For further information:

Overview, see page 352.

Checking the coolant level

1. Allow the drivetrain to cool down.
2. Open the bonnet.
Opening, see page 353.

3. Open the cover under the bonnet.

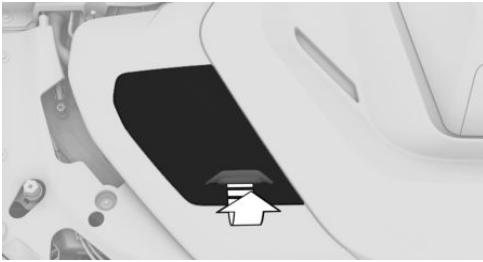

4. Turn cap on coolant expansion tank slightly anticlockwise to allow the excess pressure to escape.
5. Open cap on coolant expansion tank.
6. The coolant level is correct if it is just below the max. mark in the filler neck.



7. Tighten cap.

Disposal



When disposing of coolant and coolant additives, comply with the relevant environmental protection regulations.

Washer fluid

General

All spray nozzles are supplied from one tank.

Use a mixture of tap water and screenwash concentrate for the window washer system, if necessary with the antifreeze additive.

Recommended minimum fill level: 1 litre,
1.7 Imp. pints.

Safety notes

WARNING

Some antifreezes can contain toxic substances, and are flammable. There is a risk of fire and injury. Please comply with the instructions on the containers. Keep antifreezes away from sources of combustion. Do not pour operating fluids into other bottles. Keep operating fluids out of the reach of children.

NOTE

Silicone additives mixed with the washer fluid for their water beading effect on the windows may damage the washer system. There is a risk of material damage. Do not add silicone additives to the washer fluid.

NOTE

Mixing different screenwash concentrates or antifreezes may damage the washer system. There is a risk of material damage. Do not mix different screenwash concentrates or antifreezes. Please comply with the instructions and mixing ratios stated on the containers.

Overview



The reservoir for the washer fluid is located under the bonnet.

Malfunction

Using undiluted screenwash concentrate or anti-freeze based on alcohol may result in false readings at low temperatures below $-15\text{ }^{\circ}\text{C}/+5\text{ }^{\circ}\text{F}$.

Maintenance

Vehicle equipment

This chapter describes equipment, systems and functions which are offered or will be offered on a model-specific basis, even if they are not included in the vehicle in question.

For further information:

Vehicle equipment, see page 7.

BMW Maintenance System

The maintenance system indicates what maintenance measures are required and thereby assists in maintaining the road safety and operational safety of the vehicle.

The exact work required and the maintenance intervals may vary depending on the national-market version. Labour, spare parts, operating materials and wear materials are charged separately. Additional information is available from a Service Partner of the manufacturer or another qualified Service Partner or a specialist workshop.

Safety note

WARNING

An electric shock can occur if the work is not carried out correctly, in particular maintenance and repair of the high-voltage system. There is a danger of injury, fire or danger to life. Only have work on the vehicle, particularly maintenance, repair and modifications, carried out by a Service Partner of the manufacturer or another qualified Service Partner or a specialist workshop.

Condition Based Service CBS

Principle

Condition Based Service (CBS) determines the maintenance requirement using sensors and special algorithms which monitor the conditions in which the vehicle is used.

The system therefore allows the scope of the maintenance work to be adapted to the individual usage profile.

General

Information on service requirements can be shown on the control display.

For further information:

Service requirements, see page 166.

Service data in the vehicle key

Information on maintenance requirement is continuously stored in the vehicle key. The Service Partner can read out this data and suggest a programme of maintenance for your vehicle.

It is therefore important to give the service advisor the vehicle key that was last used to drive the vehicle.

Stationary periods

Stationary periods when the vehicle is out of use with its vehicle battery disconnected are not taken into account.

In such cases, have any time-dependent maintenance procedures, for example those concerning the brake fluid and the microfilter/active carbon filter, updated by a Service Partner of the manufacturer or another qualified Service Partner or a specialist workshop.

Service history

Maintenance and repairs

Have maintenance and repairs carried out by a Service Partner of the manufacturer or another qualified Service Partner or a specialist workshop.

Entries

The maintenance work carried out is entered in the maintenance records and the vehicle data. As with a service booklet, the entries provide evidence of regular maintenance.

If an entry is made in the electronic service history of the vehicle, service-relevant data is saved both in the vehicle and in the central IT systems of BMW AG, Munich.

After a change of registered keeper, the new owner will be able to view the data entered in the electronic service history. Similarly, a Service Partner of the manufacturer or another qualified Service Partner or a specialist workshop can also view the data entered in the electronic service history.

Objection

The registered keeper is entitled to contact a Service Partner of the manufacturer or another qualified Service Partner or a specialist workshop and request that no entries are made in the electronic service history and that no data relating to his/her time as owner is subsequently stored in the vehicle or transferred to the vehicle manufacturer. In such cases, no entries will be made in the vehicle's electronic service history.

Displays

Service work which has been logged can be displayed on the control display.

For further information:

Service requirements, see page [166](#).

For Australia: maintenance

No maintenance work other than normal maintenance is required to keep the emission levels of your vehicle within the design limits.

OBD diagnostic socket

General

Devices connected to the OBD socket trigger the alarm system when the vehicle is locked. Remove any devices connected to the OBD socket before locking the vehicle.

Safety note

NOTE

Incorrect use of the OBD on-board diagnosis socket can cause malfunctions in the vehicle. There is a risk of material damage. Only have service and maintenance work involving the OBD on-board diagnosis socket carried out by a Service Partner of the manufacturer or another qualified Service Partner or a specialist workshop or other authorised persons. Only connect devices that have been tested and found to be safe for use with the OBD on-board diagnosis socket.

Position

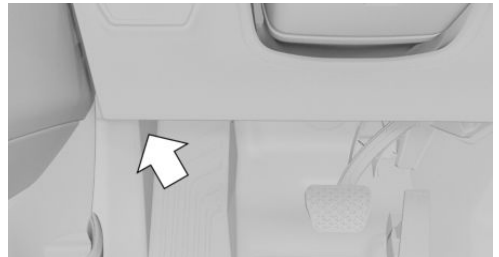

On the driver's side there is a OBD socket for reading vehicle data.

Vehicle recycling

The manufacturer of the vehicle recommends returning the vehicle to a collection point nominated by the manufacturer at the end of its life cycle. The regulations concerning the returning of end-of-life vehicles may vary from country to country. Additional information is available from a Service Partner of the manufacturer or another qualified Service Partner or a specialist workshop.

High-voltage battery recycling



The vehicle manufacturer recommends having a Service Partner of the manufacturer or another qualified Service Partner or specialist workshop dispose of high-voltage batteries that are at the end of their useful life or are faulty.

The regulations concerning the returning of end-of-life vehicles may vary from country to country. Additional information is available from a Service Partner of the manufacturer or another qualified Service Partner or a specialist workshop. For more information, see www.bmw.com.

Replacing parts

Vehicle equipment

This chapter describes equipment, systems and functions which are offered or will be offered on a model-specific basis, even if they are not included in the vehicle in question.

For further information:

Vehicle equipment, see page 7.

Toolkit



The toolkit is located in the left storage compartment of the luggage compartment, under a cover.

Wiper blades

Safety note

NOTE

The windscreen may sustain damage if a wiper falls onto it without the wiper blade fitted. There is a risk of material damage. Hold the wiper firmly when changing the wiper blade. Do not fold in or switch on the wiper without a wiper blade installed.

Replacing the wiper blades

1. To replace the wiper blades, move the wipers to the fold-out position.

For fold-out position of the windscreen wipers, see page 151.

2. Fold out the wiper arm and hold firm.
3. Press together securing spring, arrow 1, and fold out the wiper blade, arrow 2.

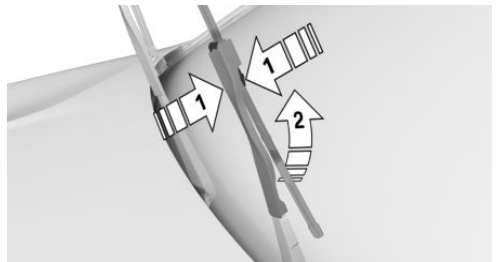

4. Remove the wiper blade forwards out of its catch.
5. Insert the new wiper blade in the opposite sequence ensuring that it clips into place.
6. Fold in the windscreen wipers.

Bulbs and lights

General

Lights and bulbs are an important aspect of driving safety.

All headlights and other lights use LED or laser technology.

Some equipment versions have light-emitting diodes behind a cover as a light source. These light-emitting diodes are similar to conventional lasers and are classified by legislation as Class 1 light-emitting diode.

In the event of a fault, the manufacturer of the vehicle recommends having the relevant work carried out by a Service Partner of the manufac-

turer or another qualified Service Partner or a specialist workshop.

Safety notes

WARNING

Concentrated laser light can cause irritation or lasting damage to the retina of the eye. There is a danger of injury. The manufacturer of the vehicle recommends having work on the lighting system, including bulb replacement, performed by a Service Partner of the manufacturer or another qualified Service Partner or a specialist workshop.

WARNING

Intense brightness can irritate or harm the retina of the eye. There is a danger of injury. Do not look directly into the headlights or other light sources. Do not remove covers from LEDs.

Headlight glass

During cool or humid weather, the headlight glass can mist over on the inside. When driving with the lights switched on, the condensation disappears after a short time. There is no need to replace the headlight glass.

If moisture increases, for example if there are water droplets in the lamp despite the headlights being switched on, have the headlights checked.

Vehicle battery

General

As well as the high-voltage battery, the vehicle has a 12-volt vehicle battery. The vehicle battery supplies the vehicle electronics with energy.

The battery is maintenance-free.

More information regarding the battery can be obtained from a Service Partner of the manufacturer or another qualified Service Partner or a specialist workshop.

Safety notes

DANGER

Touching live components can result in an electric shock. There is a risk of injury or even death. Do not touch any components that could be live.

WARNING





Vehicle batteries that are classified as unsuitable may damage systems or result in functions no longer being carried out. There is a risk of injury or material damage. Only use vehicle batteries that have been classified as suitable by the vehicle manufacturer.

Registering the battery with the vehicle

The manufacturer of the vehicle recommends having a Service Partner of the manufacturer or another qualified Service Partner or a specialist workshop register the vehicle battery with the vehicle after the battery has been replaced. Once the battery has been registered again, all comfort functions will be available without restriction and any Check Control messages relating to the comfort functions will no longer be displayed.

Hazard icons

The following hazard icons can be found on the vehicle battery:

Icon	Meaning
	No smoking, no naked flames, no sparks.
	Wear protective goggles.
	Keep away from children.
	Risk of acid burns: wear gloves, do not tilt the battery.
	Rinse any splashes of acid with water immediately. If acid comes into contact with eyes or is swallowed, seek medical attention immediately.
	No direct sunlight, no frost.
	Follow the operating instructions.
	Explosive gas mixture. Do not seal any openings on the battery.

- ▷ Park the vehicle and switch off consumers.
- ▷ First disconnect the power at the negative terminal. Then disconnect the power at the positive terminal.

Notes on installation

Observe the following notes on installing the vehicle battery:

- ▷ Remove any foreign bodies from the battery holder.
- ▷ Only install the battery in the intended position in the vehicle.
- ▷ Keep the battery and vehicle connection contacts clean.
- ▷ First connect the power at the positive terminal. Then connect the power at the negative terminal.
- ▷ Use the connections, connectors and covers provided.
- ▷ Connect a hose to the gas outlet opening if necessary.

Initial operation

The battery is operational. No special precautions are required for start-up.

Charging the battery

A battery charger installed in the vehicle supplies the vehicle battery with current. The battery charger draws the energy required from the high-voltage battery.

For further information:

Charge vehicle, see page 316.

Open circuit

Following an open circuit, some equipment will have to be reinitialised or individual settings will need to be updated, for example:

- ▷ Parking brake, see page 146.
- ▷ With memory function: save positions again.
- ▷ Time: update.

Replacing the battery

General

The manufacturer of the vehicle recommends only having the vehicle battery replaced by a Service Partner of the manufacturer or another qualified Service Partner or a specialist workshop. If the battery is not replaced correctly, the vehicle may not recognise it properly and perfect functioning cannot be guaranteed.

Notes on removal

Observe the following notes on removing the vehicle battery:

- Date: update.
- Glass sunroof: initialise system.

Storing the battery

Observe the following information on storing vehicle batteries:

- Store the battery in a cool and dry place.
- Protect the battery from direct sunlight and frost.
- Only clean the battery with a damp, anti-static cloth.
- Store the battery upright and secure it against falling over.
- Install the oldest batteries first.
- Do not remove the protective cap from the contacts.
- Charge or install the battery by the date on the battery label at the latest. Once fully charged, the battery will work for another 10 months.

Disposing of the old battery



Dispose of old batteries at a Service Partner of the manufacturer or another qualified Service Partner or a specialist workshop or hand them in to an authorised collecting point.

Batteries filled with acid should be transported upright. Protect batteries against falling over when in transit.

Warranty

See the vehicle purchase contract for information on the battery warranty.

Fuses

General

The fuses are located at different positions in the vehicle.

Information on the fuse assignment, as well as the positions of the fuse boxes, is available on the Internet: www.bmw.com/fusecard.

Safety note

WARNING

Incorrect or repaired fuses can overload electrical cables and components. There is a risk of fire. Do not repair blown fuses or replace them with fuses with a different colour or amp rating.

Replacing fuses

The vehicle manufacturer recommends having fuses changed by a Service Partner of the manufacturer or another qualified Service Partner or a specialist workshop.

Help in case of a breakdown

Vehicle equipment

This chapter describes equipment, systems and functions which are offered or will be offered on a model-specific basis, even if they are not included in the vehicle in question.

For further information:

Vehicle equipment, see page 7.

Hazard warning lights

Button in the vehicle

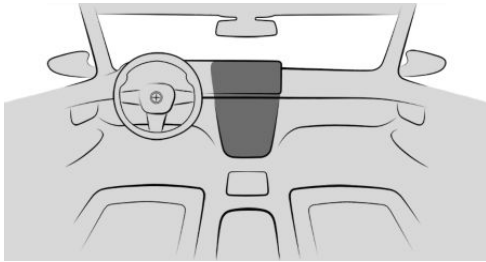

Hazard warning lights button

The red light in the button flashes when the hazard warning system is turned on.

Warning triangle

1. Turn the twist lock in the tailgate by 90°, arrow 1, and fold open the trim panel, arrow 2.

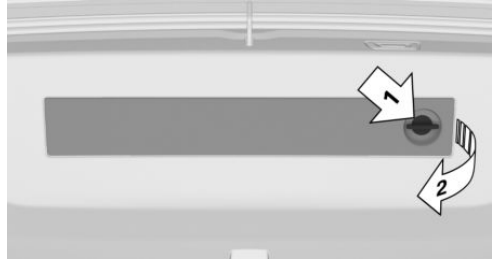

2. To remove it, slide the warning triangle to the left side.



First-aid kit

General

Depending on the equipment and the national-market version, the vehicle may have a first-aid kit.

Some items in the kit have a limited life.

Check the use-by dates of the contents regularly and replace any items that have expired in good time.

Storage

The first-aid kit is to be stored on the right-hand side of the luggage compartment.

BMW Emergency Service

Principle

BMW Group Roadside Assistance can be contacted if assistance is needed in the event of a breakdown.

General

In the event of a breakdown, data on the vehicle's condition is sent to BMW Roadside Assistance. It is possible that malfunctions can be remedied directly.

There are various ways of contacting BMW Roadside Assistance.

- ▶ Via a Check Control message.
Supplementary text messages, see page 157.
- ▶ Calling with a mobile phone.
- ▶ Via the BMW app.

Depending on the national-market version and vehicle type, a different Roadside Assistance provider can be assigned via the ConnectedDrive customer portal if necessary.

Operating requirements

- ▶ Active ConnectedDrive contract, equipment with intelligent emergency call or BMW ConnectedDrive services.
- ▶ Mobile reception.
- ▶ Standby state is switched on.

Starting BMW Roadside Assistance manually

When equipped with Teleservices, support is provided first through Teleservice Diagnosis and then by Teleservice Assistance if required.

1. "MENU"
2. "All apps"
3. "Assistance"
4. If necessary, select the entry for BMW Roadside Assistance.

A voice contact is established.

Teleservice Diagnosis

Teleservice Diagnosis enables the detailed vehicle data required for diagnosis to be transferred via mobile radio. This data is transferred automatically. It may be necessary to approve this on the Control Display.

Teleservice Assistance

Teleservice Assistance is a country-specific feature that allows BMW Roadside Assistance to carry out a more in-depth diagnosis of the vehicle via mobile radio.

Teleservice Assistance can be started after a request by BMW Roadside Assistance.

1. Park the vehicle safely.
2. Apply the parking brake.
3. Turn on control display.
4. Consent to Teleservice help.

BMW Accident Assistance

Principle

BMW Group Accident Assistance can be contacted if assistance is needed in the event of an accident.

General

If the vehicle sensors detect a minor to moderately severe accident that did not trigger any airbags, a Check Control message is displayed in the instrument cluster. A corresponding text message also appears on the control display.

When BMW Accident Assistance is activated, data on the vehicle's condition is transferred to BMW.

Depending on the national-market version and vehicle type, a different accident assistance provider can be assigned via the ConnectedDrive customer portal if necessary.

Operating requirements

- ▷ Active ConnectedDrive contract, equipment with intelligent emergency call or BMW ConnectedDrive services.
- ▷ Mobile reception.
- ▷ Standby state is switched on.

Starting BMW Accident Assistance

If an accident is detected automatically

A BMW Accident Assistance text message is shown on the control display.

The connection can be established directly:

"Contact accident assistance"

For a short time, the Check Control message for BMW Accident Assistance can also be retrieved from the saved Check Control messages.

For further information:

Check Control, see page 156.

Starting BMW Accident Assistance manually

BMW Accident Assistance can also be contacted independently of the automatic accident detection function.

1. "MENU"
2. "All apps"

3. "Assistance"

4. If necessary, select the entry for BMW Accident Assistance.

Follow the displays on the control display. A voice contact is established.

Emergency call

Statutory emergency call

Principle

The system can be used to trigger an emergency call automatically or manually in emergency situations.

General

Depending on the equipment and the national-market version, the vehicle may have an emergency call system.

Press the SOS button in an emergency only.

The emergency call establishes a connection to a public emergency call number.

This depends on factors such as the specific mobile phone network and national regulations.

The emergency call is placed using the integrated SIM card in the vehicle and cannot be switched off.

For technical reasons, it might not be possible to make an emergency call in highly adverse conditions.

Overview

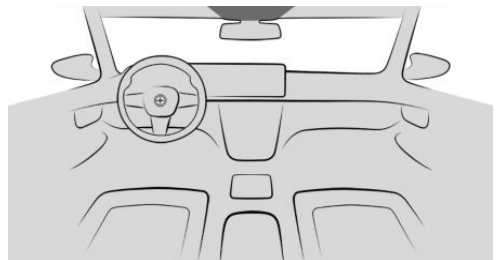



SOS button

Operating requirements

- Standby state is switched on.
- Emergency call system is functional.
- If the vehicle is equipped with intelligent emergency call: the integrated SIM card in the vehicle is activated.

Automatic triggering

In certain circumstances, for example deployment of the airbags, an emergency call may be placed automatically immediately after an accident of appropriate severity. Pressing the SOS button does not affect the automatic emergency call.

Manual triggering

1. Tap the cover flap.
 2. Press and hold the SOS button until the LED in the button area is illuminated green.
- The LED is illuminated green when the emergency call has been activated.

If a cancellation request is shown on the control display, the emergency call can be cancelled.

If the situation permits, wait in the vehicle until voice contact has been established.

- The LED flashes green when the connection to the emergency call has been established.

In an emergency call, data is sent to the public rescue coordination centre in order to decide what rescue measures are required. The data may include, for example, the vehicle's current position, if this can be determined.

For information on data transfer and storage:

Statutory emergency call system, see page 15.

Even if the vehicle occupants can no longer hear the rescue coordination centre through the loudspeakers, the rescue coordination

centre may still be able to hear the vehicle occupants speak.

The rescue coordination centre ends the emergency call.

Malfunction

The emergency call function may be impaired.

The LED in the area of the SOS button flashes for approximately 30 seconds. A Check Control message is shown.

Have checks performed by a Service Partner of the manufacturer or another qualified Service Partner or a specialist workshop.

Intelligent emergency call

Principle

The system can be used to trigger an emergency call automatically or manually in emergency situations.

General

Depending on the equipment and the national-market version, the vehicle may have an emergency call system.

Press the SOS button in an emergency only.

The intelligent emergency call system establishes a connection with the BMW emergency call centre.

Even if no emergency call through BMW is possible, in some cases an emergency call may still be established to a public emergency call number. This depends on factors such as the specific mobile phone network and national regulations.

For technical reasons, it might not be possible to make an emergency call in highly adverse conditions.

Overview

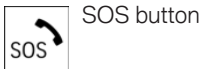
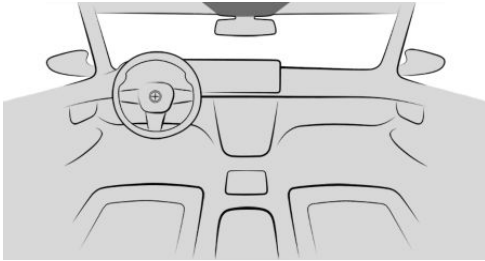

SOS button

Operating requirements

- ▶ Standby state is switched on.
- ▶ Emergency call system is functional.
- ▶ If the vehicle is equipped with intelligent emergency call: the integrated SIM card in the vehicle is activated.

Automatic triggering

In certain circumstances, for example deployment of the airbags, an emergency call may be placed automatically immediately after an accident of appropriate severity. Pressing the SOS button does not affect the automatic emergency call.

Manual triggering

1. Tap the cover flap.
 2. Press and hold the SOS button until the LED in the button area is illuminated green.
- ▶ The LED is illuminated green when the emergency call has been activated.
If a cancellation request is shown on the control display, the emergency call can be cancelled.
If the situation permits, wait in the vehicle until voice contact has been established.
 - ▶ The LED flashes green when the connection to the emergency call has been established.

When an emergency call is made through BMW, data such as the vehicle's current position, if this can be determined, is sent to the emergency call centre in order to decide what rescue measures are required.

If questions asked by the emergency call centre remain unanswered, rescue measures are implemented automatically.

Even if the vehicle occupants can no longer hear the emergency call centre through the loudspeakers, the emergency call centre may still be able to hear the vehicle occupants speak.

The emergency call centre ends the emergency call.

Malfunction

The emergency call function may be impaired.

The LED in the area of the SOS button flashes for approximately 30 seconds. A Check Control message is shown.

Have checks performed by a Service Partner of the manufacturer or another qualified Service Partner or a specialist workshop.

Fire extinguisher

Principle

The fire extinguisher can be used to put out vehicle fires.

General

Depending on the equipment and the national-market version, the vehicle may have a fire extinguisher.

Safety notes

WARNING

Incorrect use of the fire extinguisher can cause injury. There is a danger of injury. Observe the information below when using the fire extinguisher:

- ▷ Do not inhale the extinguishing agent. If the extinguishing agent is inhaled, move the casualty out into the fresh air. If the casualty experiences breathing difficulties, contact a doctor immediately.
- ▷ Do not allow the extinguishing agent to come into contact with the skin. Prolonged contact with the extinguishing agent can cause the skin to dry out.
- ▷ Do not allow the extinguishing agent to come into contact with the eyes. In the event of contact with the eyes, rinse them immediately with plenty of water. In case of prolonged discomfort, contact a doctor.

WARNING

Objects in the driver's footwell can restrict the pedal travel or block a pedal that has been pressed. There is a risk of accident. Ensure that items in the vehicle are stowed securely and cannot get into the driver's footwell.

Overview

The fire extinguisher is located in the interior, for example under the seat or in the glove compartment.

Removing the fire extinguisher

Open the buckles on the retaining strap.

Using the fire extinguisher

To use the fire extinguisher, follow the manufacturer's instructions on the fire extinguisher and the information supplied with it.

Stowing the fire extinguisher

1. Insert the fire extinguisher into the holder.
2. Hook in and close the buckles.

Maintenance and refilling

Have the fire extinguisher checked every 2 years by a Service Partner of the manufacturer or another qualified Service Partner or a specialist workshop.

Make a note of the next maintenance date for the fire extinguisher.

Replace the fire extinguisher after use or have it refilled.

Conduct after an accident

General

After an accident, take the following safety measures regarding the high-voltage system:

- ▷ Put the selector lever into position P, apply the parking brake and switch off or deactivate standby state or drive-ready state.
- ▷ Secure the area where the accident has taken place.
- ▷ Lock the vehicle when you leave it.
- ▷ Inform the fire, police or ambulance service immediately that it involves a vehicle with a high-voltage system.
- ▷ Do not inhale any gases from the high-voltage battery and keep away from the vehicle as appropriate.

Safety notes

DANGER

Touching live components can result in an electric shock. There is a danger of injury or danger to life. After an accident, do not touch any high-voltage components, for example or-

ange high-voltage cables or parts which are in contact with exposed high-voltage cables.

⚠ WARNING

Fluids in the high-voltage battery are corrosive. There is a danger of injury. Do not touch fluid from the high-voltage battery.

Jump start

General

Only ever have a Service Partner of the manufacturer or another qualified Service Partner or a specialist workshop provide jump start.

Safety note

⚠ DANGER

Touching live components can result in an electric shock. There is a risk of injury or even death. Do not touch any components that could be live.

Towing away

Safety note

⚠ WARNING

Due to system limits, individual functions can malfunction during tow-starting/tow-away when the front-collision warning is activated. There is a risk of accident. Turn the front-collision warning off prior to tow-starting/towing.

Transporting the vehicle

General

The vehicle must not be towed.

Safety notes

⚠ NOTE

If the vehicle is towed with one axle raised, the vehicle can be damaged. There is a risk of material damage. Only have the vehicle transported on a truck bed.

⚠ NOTE

The vehicle may be damaged when raising and securing it.

There is a risk of material damage.

- ▷ Raise the vehicle with suitable equipment.
- ▷ Do not raise or secure the vehicle by its towing eye, body parts or chassis parts.

Pushing the vehicle

To remove a broken-down vehicle from a dangerous area, it can be pushed over a short distance at a maximum speed of 10 km/h, 6 mph.

For further information:

For rolling or pushing the vehicle, see page 140.

Recovery vehicle

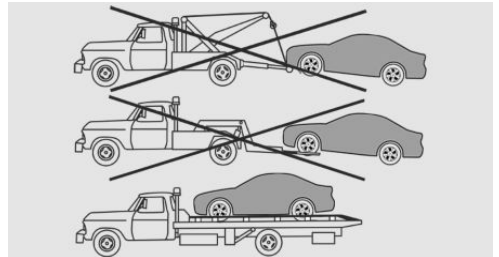

Only have the vehicle transported on a loading platform.

Towing other vehicles

General

Switch on the hazard warning lights in line with local regulations.

If the electrical system of the vehicle being towed has failed, the vehicle must be made identifiable to other road users, for instance by placing a sign or the warning triangle in the rear window.

Safety notes

⚠ WARNING

If the gross vehicle weight of the towing vehicle is less than that of the vehicle being towed, the towing eye may be torn off or it may not be possible to control the vehicle. There is a risk of accident. Make sure that the gross vehicle weight of the towing vehicle is greater than the weight of the vehicle being towed.

⚠ NOTE

If the tow bar or the towing rope is not attached correctly, other vehicle parts can be damaged. There is a risk of material damage. Attach the tow bar or towing rope to the towing eye correctly.

Towbar

The towing eyes of both vehicles should be on the same side.

If it is impossible to avoid attaching the towbar at an angle, note the following:

- ▷ Clearance may be restricted when cornering.
- ▷ Lateral force will be generated if the towbar is installed at an angle.

Towing rope

Note the following if using a towing rope:

- ▷ Use nylon ropes or straps that will allow the vehicle to be towed smoothly.
- ▷ Fasten the towing rope so it is not twisted.
- ▷ Check the towing eye and towing rope fastening regularly.
- ▷ Do not exceed a towing speed of 50 km/h, 30 mph.
- ▷ Do not exceed a towing distance of 5 km, 3 miles.
- ▷ Ensure that the towing rope is taut when the towing vehicle drives off.

Towing eye

General



Always keep the screw-on towing eye in the vehicle.

The towing eye can be screwed in at the front or rear of the vehicle.

The towing eye is located in the toolkit.

Observe the following notes when using the towing eye:

- ▷ Only use the towing eye supplied with the vehicle.
- ▷ Turn the towing eye at least 5 turns clockwise and screw it in tight and as far as it will go. If necessary, tighten with a suitable object.
- ▷ After use, unscrew the towing eye in an anti-clockwise direction.
- ▷ Only use the towing eye for towing on paved roads.

- ▶ Avoid transverse loads on the towing eye, for example do not raise the vehicle by the towing eye.
- ▶ Check the towing eye fastening regularly.

For further information:

Toolkit, see page [360](#).

Safety note

NOTE

If the towing eye is not used as intended, the vehicle or towing eye may be damaged. There is a risk of material damage. Observe the notes on using the towing eye.

Thread for towing eye



Press the marking on the edge of the cover to press it out.

Care

Vehicle equipment

This chapter describes equipment, systems and functions which are offered or will be offered on a model-specific basis, even if they are not included in the vehicle in question.

For further information:

Vehicle equipment, see page 7.

Vehicle wash

General

Regularly remove foreign objects, for example, leaves or snow, in the area below the wind-screen.

Wash the vehicle frequently, especially in winter. Heavy soiling and road salt can cause damage to the vehicle.

For further information:

For fold-out position of the windscreen wipers, see page 151.

Safety notes

WARNING

Touching live components can result in an electric shock. High voltage is present at the charging socket. There is a risk of injury or even death. Have work on the charging socket, for example cleaning, performed by a Service Partner of the manufacturer or another qualified Service Partner or a specialist workshop.

NOTE

The charging socket outlet may be damaged when the charging socket flap is open while washing. There is a risk of material damage. Close the charging socket flap before washing. Remove any dirt behind the charging socket flap with a cloth.

High-pressure cleaners

Safety note

NOTE

When cleaning with high-pressure cleaners, excessive pressure or excessive temperatures can damage various components. There is a risk of material damage. Maintain a sufficient distance and do not spray for an extended period of time. Comply with the instructions for the high-pressure cleaner.

Distances and temperature

- ▷ Maximum temperature: 60 °C/140 °F.
- ▷ Minimum distance to sensors, cameras, seals: 30 cm, 12 in.
- ▷ Minimum distance to the glass sunroof: 80 cm, 31.5 in.

Automatic car washes

Safety notes

NOTE

If high-pressure washers are used, water may penetrate the area around the windows. There is a risk of material damage. Do not drive in high-pressure washers.

NOTE

The vehicle can be damaged if automatic car washes are used incorrectly. There is a risk of material damage. Observe the following notes:

- ▷ Textile car washes or systems using soft brushes are preferable, to avoid damage to the paintwork.
- ▷ Do not drive into automatic car washes or washing bays with guide rails higher than 10 cm, 4 in, to avoid damage to the body.
- ▷ Note the maximum tyre width of the guide rail to avoid damage to tyres and rims.
- ▷ Fold in the exterior mirrors to avoid damaging them.
- ▷ Deactivate the windscreen wipers and the rain sensor (if fitted) to avoid damage to the wiper system.

Entering a car wash

Safety note

NOTE

Selector lever position P is automatically engaged when standby state is switched off. There is a risk of material damage. Do not switch off standby state in car washes.

General

The vehicle must be able to roll freely while in the car wash.

Some car washes require you to leave the vehicle. It is not possible to lock the vehicle from the outside in selector lever position N. If an attempt is made to lock the vehicle, a signal sounds.

For further information:

For rolling or pushing the vehicle, see page 140.

Exiting from a car wash

Make sure that the vehicle key is in the vehicle.

Switch on drive-ready state.

For further information:

Drive-ready state, see page 52.

Headlights

Do not rub wet headlights dry and do not use abrasive or corrosive cleaning agents.

Soak impurities, for example insect residues, with shampoo and wash off with water.

Remove ice with a de-icer spray; do not use an ice scraper.

After vehicle wash

After vehicle wash, briefly apply the brakes to dry them, otherwise braking effect may be temporarily reduced. The heat generated by braking dries the brake discs and brake pads and protects them against corrosion.

Completely remove residues on the windcreens to avoid affecting visibility due to smearing and to reduce wiping noise and wiper blade wear.

Vehicle care

Care products

General

BMW recommends using care and cleaning products from BMW. Suitable care products are

available from a Service Partner of the manufacturer or another qualified Service Partner or a specialist workshop.

Safety note

WARNING

Cleaning agents can contain hazardous substances or constitute a health risk. There is a danger of injury. When cleaning the interior, open the doors or windows. Use only products that are intended for cleaning the vehicle's interior. Observe the notes on the packaging.

Vehicle paintwork

General

Regular care promotes driving safety and preserves your vehicle's value. Environmental effects in areas with high air pollution or natural contaminants, for example tree resin or pollen, may affect the vehicle paintwork. Take such factors into consideration when deciding on the frequency and scope of vehicle care measures.

Immediately remove aggressive substances, for example oil, grease or bird droppings to prevent paintwork damage and discolouration.

Matt paintwork

Only use cleaning and care products that are suitable for vehicles with matt paintwork.

Leather care

Remove dust from the leather at regular intervals with a cloth or vacuum cleaner.

Dust and road dirt will otherwise become worked into pores and folds, resulting in considerable abrasion and causing the leather surface to become prematurely brittle.

To protect against discolouration, for example from clothing, clean and care for the leather approximately every two months.

Clean light-coloured leather more frequently as it has the tendency to soil faster.

Use leather cleaner, otherwise dirt and grease will attack the protective coating of the leather.

Remove aggressive substances, such as sunscreen, immediately to prevent the leather from being altered or discoloured.

Synthetic leather care

Clean the synthetic leather regularly with a damp microfibre cloth or vacuum cleaner.

Dust and road dirt will otherwise become worked into pores and folds, resulting in considerable abrasion and causing the surface to become prematurely brittle.

In case of major contaminations, use a moist soft sponge or microfibre cloth with a suitable interior cleaners.

Remove aggressive substances, for example sunscreen, immediately to prevent the synthetic leather from being altered or discoloured.

Fabric care

General

In case of major contaminations, such as beverage stains, use a moist soft sponge or microfibre cloth with a suitable interior cleaners.

Remove aggressive substances, for example sunscreen, immediately to prevent the fabric from being altered or discoloured.

Safety note

NOTE

Open hook and loop fasteners on articles of clothing can damage the seat covers and other cloth upholstery in the vehicle. There is a risk of material damage. Make sure that the hook and loop fasteners are closed.

Care of upholstery fabrics

Vacuum regularly with a vacuum cleaner.

Clean extensively down to the seams. Avoid rubbing vigorously.

Textile care

Use a microfibre cloth for cleaning minor contamination.

Dampen the cloth with water.

Care of special parts

Light alloy wheels

When cleaning the wheels while they are installed on the vehicle, only use neutral rim cleaner with a pH value between 5 and 9. Do not use abrasive cleaners or high-pressure cleaners above 60 °C/140 °F. Observe the manufacturer's instructions.

Corrosive, acidic or alkaline cleaners may destroy the protective coatings of adjacent parts, for example brake disc.

After cleaning, briefly apply the brakes to dry them. The heat generated by braking dries the brake discs and brake pads and protects them against corrosion.

Chrome-like surfaces

Carefully clean chrome-like surfaces with plenty of water, particularly if they have been exposed to road salt; add shampoo if need be.

Rubber parts

The surfaces of rubber parts can be contaminated or lose their shine due to environmental influences. Only use water and suitable care products for cleaning.

Rubber parts subjected to high wear and tear should be treated regularly with rubber care products. Do not use silicone-based care products for treating rubber seals, otherwise these could be damaged and become a source of noise.

Wiper blades

The wiper blades are cleaned by using the window washer system.

Avoid additional manual cleaning of the wiper blades to prevent a reduction in wipe quality.

Fine wood parts

Clean fine wood trims and fine wood parts with a damp cloth only. Then dry them with a soft cloth.

Kenaf

Treat parts made from kenaf fibres with a suitable care product only.

Plastic parts

NOTE

Cleaning agents containing alcohol or solvents, for example nitro thinners, cold cleaners, fuel or similar can damage plastic parts. There is a risk of material damage. Clean with a microfibre cloth. Lightly moisten the cloth with water if necessary.

Clean with a microfibre cloth.

Lightly moisten the cloth with water if necessary.

Do not soak the headliner.

Seat belts

WARNING

Chemical cleaners can cause irreparable damage to the fabric of the seat belts. The protective function of the seat belts will be lost. There is a risk of injury or even death. Only use a mild soap and water solution for cleaning the seat belts.

Dirt on the seat belt straps can interfere with the action of the reel and is a safety hazard.

Only clean the seat belt straps with a mild soap solution while still fitted to the vehicle.

Do not allow seat belts to retract until they are dry.

Carpets and floor mats

WARNING

Objects in the driver's footwell can restrict the pedal travel or block a pedal that has been pressed. There is a risk of accident. Ensure that items in the vehicle are stowed securely and cannot get into the driver's footwell. Only use floor mats that are suitable for the vehicle and can be securely fastened to the floor. Do not use loose floor mats, and do not place several floor mats on top of one another. Make sure that there is sufficient space for the pedals. Ensure that floor mats are securely reattached after removal, for example for cleaning.

Floor mats can be removed from the vehicle to enable the interior to be cleaned more thoroughly.

In the event of heavy soiling, clean floor carpets using a microfibre cloth and water or textile cleaner. Rub back and forth in the direction of travel to prevent matting.

Displays, screens and protective glass of the head-up display

NOTE

Chemical cleaners, moisture or fluids of all kinds can damage the surface of displays and screens. There is a risk of material damage. Clean with a clean, anti-static microfibre cloth.

NOTE

Incorrect cleaning can damage the surfaces of displays. There is a risk of material damage. Avoid applying excessive pressure and do not use abrasive materials.

Use a dry, clean antistatic microfibre cloth.

Depending on the equipment: clean the protective glass of the head-up display using a microfibre cloth and commercially available dish-washing soap.

Sensors and camera lenses

Clean sensors or camera lenses using a cloth moistened with a small amount of glass cleaner.

Technical data

Vehicle equipment

This chapter describes equipment, systems and functions which are offered or will be offered on

a model-specific basis, even if they are not included in the vehicle in question.

For further information:

Vehicle equipment, see page 7.

General

The technical data and specifications in the Owner's Handbook are reference figures. Data relating to a specific vehicle can deviate from this, for example, due to selected optional equipment, national-market versions or country-specific measurement procedures. Detailed values can be found in the permit documents, on signs

on the vehicle or can be requested from a Service Partner of the manufacturer or another qualified Service Partner or a specialist workshop.

The information in the vehicle documents always takes precedence over the information in the Owner's Handbook.

Dimensions

Dimensions can vary depending on the model version, equipment or country-specific measurement method.

In addition, the height of the vehicle may vary, for example, due to tyres and load.

BMW i4 Gran Coupé

Width with mirrors	mm (in)	2073 (81.6)
Width without mirrors	mm (in)	1886 (74.3)
Height	mm (in)	1448 (57)
Length	mm (in)	4783 (188.3)
Wheelbase	mm (in)	2856 (112.4)
Smallest turning circle dia.	m (ft)	12.5 (41.0)

Weights

i4 eDrive40

Vehicle kerb weight ready for use, with 75 kg load, no optional equipment	kg (lb)	2125 (4685)
Permitted total weight	kg (lb)	2605 (5743)
Payload	kg (lb)	555 (1224)
Front axle load limit	kg (lb)	1140 (2513)
Rear axle load limit	kg (lb)	1550 (3417)
Permitted roof load	kg (lb)	75 (165)

i4 M50

Vehicle kerb weight ready for use, with 75 kg load, no optional equipment	kg (lb)	2290 (5049)
Permitted total weight	kg (lb)	2735 (6030)
Payload	kg (lb)	520 (1146)
Front axle load limit	kg (lb)	1270 (2800)
Rear axle load limit	kg (lb)	1550 (3417)
Permitted roof load	kg (lb)	75 (165)

Trailer operation

i4 eDrive40

Trailer loads according to EU operating permit. Consult manufacturer's Service Partner or another qualified Service Partner or a specialist workshop about options for increasing the loads.

Trailer load without brake	kg (lb)	750 (1653)
Trailer load with brake on upward gradient up to 12 %	kg (lb)	1600 (3527)
Trailer load with brake on upward gradient up to 8 %	kg (lb)	1600 (3527)
Maximum trailer nose weight	kg (lb)	75 (165)
Minimum trailer nose weight	kg (lb)	25 (55)

i4 eDrive40

Rear axle load limit, towing vehicle	kg (lb)	1660 (3660)
Permitted total weight, towing vehicle	kg (lb)	2680 (5908)

i4 M50

Trailer loads according to EU operating permit. Consult manufacturer's Service Partner or another qualified Service Partner or a specialist workshop about options for increasing the loads.

Trailer load without brake	kg (lb)	750 (1653)
Trailer load with brake on upward gradient up to 12 %	kg (lb)	1600 (3527)
Trailer load with brake on upward gradient up to 8 %	kg (lb)	1600 (3527)
Maximum trailer nose weight	kg (lb)	75 (165)
Minimum trailer nose weight	kg (lb)	25 (55)
Rear axle load limit, towing vehicle	kg (lb)	1660 (3660)
Permitted total weight, towing vehicle	kg (lb)	2810 (6195)

Seats for child restraint systems

Vehicle equipment

This chapter describes equipment, systems and functions which are offered or will be offered on a model-specific basis, even if they are not included in the vehicle in question.

For further information:

Vehicle equipment, see page 7.

Information for manufacturers of child seats

General

Information about which child restraint systems can be used on each seat, in accordance with the ECE-R 16 and ECE-R 129 standard.

Left-hand drive vehicles: Suitability of child restraint systems for each vehicle seat

Seat position	1	3 – Airbag ON	3 – Airbag OFF	4	5	6
Seat position suitable for universal fastening with a belt.	No	No	Yes	Yes	Yes	Yes
i-Size seat position.	No	No	No	Yes	No	Yes
Seat position suitable for side mounting: L1/L2.	No	No	No	Yes	No	Yes
Largest rear-facing mounting: R1/R2X/R2/R3.	No	No	No	R3	No	R3
Largest front-facing mounting: F2X/F2/F3.	No	No	No	F3	No	F3
Largest suitable booster mount: B2/B3.	No	No	No	B3	No	B3

A seat position without i-Size approval is not compatible with an i-Size support stand.

A seat position with lower ISOFIX anchors, but with no top tether, is not available.

There are no seat belt buckles for adults between the two bottom ISOFIX anchors.

Seat number	Position in the vehicle	Seat number	Position in the vehicle
1	Front left	3	Front right
2	Front centre	4	Second-row seating left

Seat number	Position in the vehicle
5	Second-row seating centre
6	Second-row seating right
7	Third-row seating left

Seat number	Position in the vehicle
8	Third-row seating centre
9	Third-row seating right

Right-hand drive vehicles: suitability of child restraint systems for each vehicle seat

Seat position	1 – Airbag ON	1 – Airbag OFF	3	4	5	6
Seat position suitable for universal fastening with a belt.	No	Yes	No	Yes	Yes	Yes
i-Size seat position.	No	No	No	Yes	No	Yes
Seat position suitable for side mounting: L1/L2.	No	No	No	Yes	No	Yes
Largest rear-facing mounting: R1/R2X/R2/R3.	No	No	No	R3	No	R3
Largest front-facing mounting: F2X/F2/F3.	No	No	No	F3	No	F3
Largest suitable booster mount: B2/B3.	No	No	No	B3	No	B3

A seat position without i-Size approval is not compatible with an i-Size support stand.

A seat position with lower ISOFIX anchors, but with no top tether, is not available.

There are no seat belt buckles for adults between the two bottom ISOFIX anchors.

Seat number	Position in the vehicle
1	Front left
2	Front centre
3	Front right
4	Second-row seating left
5	Second-row seating centre
6	Second-row seating right

Seat number	Position in the vehicle
7	Third-row seating left
8	Third-row seating centre
9	Third-row seating right

Appendix

General

Here is where any updates to the Owner's Handbook for the vehicle are listed.

Updates after going to press

After the Integrated Owner's Handbook in the vehicle went to press, the following chapters were updated in the printed Owner's Handbook:

- ▶ Operation: opening and closing: access to the vehicle interior: with the vehicle key: comfort entry.
- ▶ Mobility: care: vehicle wash: entering a car wash.

Everything from A to Z

Index

0-9

3D view [256](#)

A

ABS Anti-lock Brake System [220](#)

ACC, Cruise Control with distance control [229](#)

Acceleration assistant, see Launch Control [143](#)

Accelerator pedal settings [141](#)

Accessories and parts [9](#)

AC charging station, see Vehicle charging [316](#)

Accident, conduct [369](#)

Accident prevention, see Active Protection [216](#)

Acoustic protection for pedestrians [136](#)

AC quick charge cable, see Mode 3 charging cable [318](#)

Activation, airbags [188](#)

Activation, towing a trailer [306](#)

Active Cruise Control [229](#)

Active front flap, see Active pedestrian protection [189](#)

Active Park Distance Control [263](#)

Active pedestrian protection [189](#)

Active Protection [216](#)

Active seat ventilation [123](#)

Active shock absorber adjustment, see Adaptive M suspension [271](#)

Adaptive brake assist [220](#)

Adaptive brake light, see Dynamic brake lights [214](#)

Adaptive Headlights [181](#)

Adaptive lighting functions [180](#)

Adaptive M suspension [271](#)

Age of tyres [330](#)

Airbags [186](#)

Airbags, indicator/warning lamp [187](#)

Airbag switch, see Key switch for front passenger airbags [188](#)

Air conditioning [273](#)

Air distribution, manual [278](#)

Air pressure, tyres [327](#)

Air quality [279](#)

Alarm signal, high-voltage battery [21](#)

Alarm system [102](#)

All-season tyres, see Winter tyres [331](#)

Ambient lighting [185](#)

Amount of air, automatic air conditioning [277](#)

Android Auto, connection to vehicle [81](#)

Android Auto preparation, connection to vehicle [81](#)

Android Auto preparation, smartphone integration [81](#)

Angle, backrest [112](#)

Antifreeze protection, see Washer fluid [355](#)

Antifreeze, see Washer fluid [355](#)

Anti-lock Brake System ABS [220](#)

Anti-slip control, see Dynamic Stability Control [220](#)

Anti-theft alarm system, see Alarm system [102](#)

Anti-theft security system, locking wheel bolts [349](#)

Anti-trap mechanism, glass sunroof [108](#)

Anti-trap mechanism, windows [105](#)

Apple CarPlay preparation, connection to vehicle [80](#)

Apple CarPlay preparation, smartphone integration [80](#)

Apps, see Owner's Handbook for Navigation, Entertainment, Communication [6](#)

Aquaplaning [299](#)

Artificial engine noise, see Acoustic protection for pedestrians [136](#)

Ashtray [282](#)

Assisted Driving Mode, see Steering and lane control assistant [241](#)

Assisted Driving Plus [244](#)

Assisted View [154](#)

Attentiveness Assistant [217](#)

- Audio, see Owner's Handbook for Navigation, Entertainment, Communication [6](#)
- AUTO H button, see Automatic Hold [147](#)
- Automatic air conditioning [273](#)
- Automatic air recirculation control [277](#)
- Automatic camera perspective [255](#)
- Automatic car wash [373](#)
- Automatic deactivation of the high-voltage system [22](#)
- Automatic dimming, see High beam assistant [182](#)
- Automatic driving lights [177](#)
- Automatic driving lights control [177](#)
- Automatic formation of emergency lane [248](#)
- Automatic Hold [147](#)
- Automatic locking [101](#)
- Automatic parking function, exterior mirror [120](#)
- Automatic rear air-conditioning system, disabling operating elements [274](#)
- Automatic time setting [165](#)
- Automatic unlocking [100](#)
- Automating habits, BMW Intelligent Personal Assistant [64](#)
- AUTO program, automatic air conditioning [275](#)
- Average consumption, see Journey data [171](#)
- Avoiding false warnings [103](#)
- Axle loads, permitted [379](#)
- ## B
- Backrest angle [112](#)
- Backrest contour, see Lumbar support [113](#)
- Backrest, seats [110](#)
- Backrest width [113](#)
- Bad weather light [183](#)
- Ball linkage electrically swivellable [306](#)
- Bar for tow-starting/towing [371](#)
- Battery changing, vehicle key [85](#)
- Battery charging, see Charging the vehicle [316](#)
- Battery, charging status display [163](#)
- Battery, disposing of [363](#)
- Battery for high-voltage system, long stationary periods [325](#)
- Battery, vehicle [361](#)
- B, drive position [139](#)
- Belts, see Seat belts [113](#)
- Blower, see Amount of air [277](#)
- Bluetooth connection [77](#)
- Blu-ray, see Owner's Handbook for Navigation, Entertainment, Communication [6](#)
- BMW Accident Assistance [365](#)
- BMW Digital Key [96](#)
- BMW Drive Recorder [214](#)
- BMW eDrive [135](#)
- BMW ID [71](#)
- BMW Intelligent Personal Assistant [61](#)
- BMW Maintenance System [357](#)
- BMW Roadside Assistance [365](#)
- BMW Services, see Owner's Handbook for Navigation, Entertainment, Communication [6](#)
- Bonnet [352](#)
- Bottle holder, front, see Cup holder, front [290](#)
- Bottle holder, rear, see Cup holder, rear [290](#)
- Bottleneck support, see Steering and lane control assistant [241](#)
- Brake assist [220](#)
- Brake assist, adaptive [220](#)
- Brake discs, see Brake system [298](#)
- Brake lights, adaptive, see Dynamic brake lights [214](#)
- Brake lights, dynamic [214](#)
- Brake pads, see Brake system [298](#)
- Brake, see Drive position B [139](#)
- Brake system [298](#)
- Braking, notes [299](#)
- Braking safely [299](#)
- Breakdown, help [364](#)
- Break recommendations, see Attentiveness Assistant [217](#)
- Brightness, control display [57](#)
- Bulbs and lights [360](#)
- Button, AUTO H, see Automatic Hold [147](#)
- Button, central locking system [99](#)
- Buttons on the steering wheel [42](#)
- Button SOS, see Intelligent emergency call [367](#)
- Button SOS, see Statutory emergency call [366](#)
- Button, start/stop [137](#)
- ## C
- Calendar day, see Date [165](#)

- Camera instrument cluster, see Driver Attention
Camera [218](#)
- Camera lenses, care [377](#)
- Camera perspective, automatic [255](#)
- Camera, Reversing Assist camera [255](#)
- Cameras, see Sensors of the vehicle [47](#)
- CANCEL button, Active Cruise Control [229](#)
- CANCEL button, cruise control [226](#)
- Can holder, front, see Cup holder, front [290](#)
- Can holder, rear, see Cup holder, rear [290](#)
- Care [373](#)
- Care, Head-Up Display [377](#)
- Care, light-alloy wheels [376](#)
- Care of upholstery fabrics [375](#)
- Care products [374](#)
- Care, vehicle [374](#)
- Caring for displays, monitors [377](#)
- Car key, see Vehicle key [84](#)
- Carpet, care [377](#)
- CarPlay, connection to vehicle [80](#)
- Carrying children [124](#)
- Carrying children safely [124](#)
- Car wash [373](#)
- Car wash, automatic [373](#)
- Car wash view [257](#)
- CBS Condition Based Service [357](#)
- Central key, see Vehicle key [84](#)
- Central locking switch, see Central locking system [99](#)
- Central locking system [99](#)
- Central screen, see Control display [57](#)
- Centre armrest, front [289](#)
- Centre console [45](#)
- Changes, technical, see Your own safety [8](#)
- Change, wheels and tyres [330](#)
- Changing bulbs, see Lights and bulbs [360](#)
- CHARGE, energy recuperation [136](#)
- Charging a smartphone, see Wireless charging dock [285](#)
- Charging cable, Flexible Fast Charger [319](#)
- Charging cable, high-voltage battery [318](#)
- Charging cable, ID [318](#)
- Charging cables, stowing, see Storage [319](#)
- Charging dock for smartphones, see Wireless charging dock [285](#)
- Charging process, see Charging screen [155](#)
- Charging screen [155](#)
- Charging, see Charging the vehicle [316](#)
- Charging status display, high-voltage battery [163](#)
- Charging status display, indicator light on the charging socket outlet [322](#)
- Charging status, indicator light on the charging socket outlet [322](#)
- Charging the battery, see Charging the vehicle [316](#)
- Charging the vehicle [316](#)
- Charging, vehicle [316](#)
- Chassis number, see Vehicle identification number [19](#)
- Check Control [156](#)
- Child locks [133](#)
- Child restraint systems, i-Size [127](#)
- Child restraint systems, see Carrying children safely [124](#)
- Child safety seat fasteners, ISOFIX [126](#)
- Child seat classes, see Suitable seats for child restraint systems [129](#)
- Child seat mounting [125](#)
- Child seats, see Carrying children safely [124](#)
- Chrome-plated surfaces, care [376](#)
- Chrome surfaces, care [376](#)
- Cigarette lighter [283](#)
- Cleaning displays, monitors [377](#)
- Cleaning, Head-Up Display [377](#)
- Closing with a smartphone, see BMW Digital Key [96](#)
- Closing with the Key Card [95](#)
- Coasting [313](#)
- Coasting in idle [313](#)
- Coat hooks [291](#)
- Collision Warning, see Front-collision warning [192](#)
- Collision warning systems [191](#)
- COMFORT, see Driving Experience Control [144](#)
- Communication, see Owner's Handbook for Navigation, Entertainment, Communication [6](#)
- Compartments in the doors [289](#)
- Compatible devices, see Suitable devices [76](#)
- Compressor [334](#)
- Concierge Service, see Owner's Handbook for Navigation, Entertainment, Communication [6](#)

- Condensation when vehicle is parked [300](#)
Condensation, windscreen [278](#)
Condition Based Service CBS [357](#)
ConnectedDrive, see Owner's Handbook for Navigation, Entertainment, Communication [6](#)
Connecting a device [75](#)
Connecting electrical devices, see Sockets [283](#)
Connecting, mobile devices [75](#)
Consumption, see Journey data [171](#)
Contacts, see Owner's Handbook for Navigation, Entertainment, Communication [6](#)
Contact with water, high-voltage system [21](#)
Continuing a journey with a flat tyre [343](#), [347](#)
Control display [57](#)
Control display, brightness [57](#)
Control display, pop-ups [56](#)
Control systems, driving stability [220](#)
Converting the headlights, see Right-hand/left-hand traffic [184](#)
Coolant [354](#)
Coolant level [354](#)
Cooling, maximum [277](#)
Cooling system [354](#)
Cornering light [181](#)
Corrosion of brake discs [300](#)
Crossing traffic warning [212](#)
Crossroads Warning, see Front-collision warning [192](#)
Cruise Control, see Cruise Control [226](#)
Cruise Control, see Cruise Control with distance control [229](#)
Cruise Control with distance control [229](#)
Cruise Control without distance control [226](#)
Cup holder, front [290](#)
Cup holder, rear [290](#)
Current driving condition [173](#)
Customer support, see Owner's Handbook for Navigation, Entertainment, Communication [6](#)
- D**
- Damage, tyres [329](#)
Dashboard, see Instrument cluster [153](#)
Dash cam, see BMW Drive Recorder [214](#)
Data protection, settings [70](#)
Data, see Deleting personal data [70](#)
Data storage medium, see Vehicle data and data protection [10](#)
Data, technical [378](#)
Date [165](#)
Daytime running lights [180](#)
DCC, Cruise Control without distance control [226](#)
DC charging cable [318](#)
Deactivation, airbags [188](#)
Deceleration and energy recuperation [141](#)
Defrosting, see Defrosting the windscreen [278](#)
Defrosting, windscreen [278](#)
Deleting personal data [70](#)
Departure schedule, see Stationary air conditioning [280](#)
Departure times, stationary air conditioning [281](#)
Destination entry, see Owner's Handbook for Navigation, Entertainment, Communication [6](#)
Detecting traffic lights [239](#)
Device list [76](#)
Diagnosis connection [358](#)
Digital Key, see BMW Digital Key [96](#)
Dimensions [378](#)
Dimming exterior mirror [120](#)
Dimming interior mirror [120](#)
Dipping headlights, see High beam assistant [182](#)
Direct dial buttons, see Shortcuts [56](#)
Direction indicators, see Turn indicators [148](#)
Disabling operating elements, automatic rear air-conditioning system [274](#)
Display charge state, high-voltage battery [163](#)
Display charging process, see Charging screen [155](#)
Display, current driving condition [173](#)
Display, iDrive [55](#)
Display information on Driver Assistance, see Assisted View [154](#)
Display information on Parking Manoeuvre Assistant, see Assisted View [154](#)
Display in the windscreen, see Head-Up Display [174](#)
Display lighting, see Instrument lighting [184](#)
Display panel, see Instrument cluster [153](#)
Displays [153](#)
Displays and symbols [7](#)

Displays for the vehicle, see Live Vehicle [171](#)
Display speed limit, see Speed Limit Info [167](#)
Disposal, coolant [355](#)
Disposal, vehicle battery [363](#)
Disposing of the old battery [363](#)
Distance control, see Cruise Control [229](#)
Distance warning, see Park Distance Control [260](#)
Door handle lighting, see Welcome light [179](#)
Door opening angle [259](#)
Downhill gradients [300](#)
Drinks holder, front, see Cup holder, front [290](#)
Drinks holder, rear, see Cup holder, rear [290](#)
Drive mode, see Driving Experience Control [144](#)
Drive-off assistant, see Dynamic Stability Control [220](#)
Drive position B, Brake [139](#)
Drive power reduced, see Heavily discharged high-voltage battery [166](#)
Driver activity, see Driver Attention Camera [218](#)
Driver assistance, parking, see Parking assistance systems [251](#)
Driver assistance systems [224](#)
Driver Attention Camera [218](#)
Driver Attentiveness Camera, see Driver Attention Camera [218](#)
Drive-ready state in detail [137](#)
Drive-ready state, see Operating condition of the vehicle [51](#)
Drive-ready state, switching off [137](#)
Drive-ready state, switching on [137](#)
Driver profiles [71](#)
Driver profiles, welcome screen [71](#)
Drive sound [272](#)
Driving [135](#)
Driving Assistant, see Collision warning systems [191](#)
Driving comfort [271](#)
Driving condition, display [173](#)
Driving Experience Control [144](#)
Driving hints [298](#)
Driving in detail [141](#)
Driving information, running in [298](#)
Driving lights control, automatic [177](#)
Driving notes, general [298](#)
Driving path lines, Reversing Assist camera [254](#)

Driving, see Drive-ready state in detail [137](#)
Driving Stability Control Systems [220](#)
Driving, Start/Stop button [137](#)
Driving style analysis, ECO PRO [312](#)
Driving style, eDRIVE drive system [311](#)
Driving through water [299](#)
DSC, see Dynamic Stability Control [220](#)
DTC, Dynamic Traction Control [222](#)
Dynamic brake lights [214](#)
Dynamic damping, see Adaptive M suspension [271](#)
Dynamic ECO lighting function [180](#)
Dynamic Stability Control [220](#)
Dynamic Traction Control DTC [222](#)

E

ECO lighting function, dynamic [180](#)
ECO PRO, driving style analysis [312](#)
ECO PRO INDIVIDUAL, see Driving Experience Control [144](#)
ECO PRO, see Driving Experience Control [144](#)
eDRIVE drive system, driving style [311](#)
eDRIVE, electric driving, see BMW eDRIVE [135](#)
Efficient4x4, see xDrive [223](#)
Electrical power window switches [103](#)
Electric driving [141](#)
electric driving, see BMW eDRIVE [135](#)
Electric range [165](#)
E-mail, see Owner's Handbook for Navigation, Entertainment, Communication [6](#)
Emergency assistance, see BMW Accident Assistance [365](#)
Emergency assistance, see BMW Roadside Assistance [365](#)
Emergency brake, see Emergency stop assistant [210](#)
Emergency braking, see PostCrash – iBrake [217](#)
Emergency call [366](#)
Emergency luggage compartment release [95](#)
Emergency release, tailgate [95](#)
Emergency release, transmission lockout [140](#)
Emergency running properties, tyres [332](#)
Emergency service, see BMW Accident Assistance [365](#)
Emergency stop assistant [210](#)

- Energy recuperation and deceleration [141](#)
Energy recuperation, CHARGE [136](#)
Engine compartment, see Under the front flap [352](#)
Engine coolant [354](#)
Engine idling when driving, see Coasting [313](#)
Engine noise, artificial, see Acoustic protection for pedestrians [136](#)
Engine start, see Starting aid [370](#)
Entering an address, Navigation, see Owner's Handbook for Navigation, Entertainment, Communication [6](#)
Entering letters and numbers [55](#)
Entertainment, see Owner's Handbook for Navigation, Entertainment, Communication [6](#)
Entertainment, selection list in the instrument cluster [170](#)
Equipment, interior [282](#)
ESP Electronic Stability Programme, see Dynamic Stability Control [220](#)
Evasion Assistant, see Front-collision warning [192](#)
Exchange, wheels and tyres [330](#)
Exterior lights with the vehicle locked [179](#)
Exterior mirror [119](#)
Exterior mirror, automatically dimming [120](#)
Exterior mirror, automatic parking function [120](#)
Exterior mirror internal [120](#)
Exterior mirrors, malfunction [119](#)
External start, see Starting aid [370](#)
Eye for securing cable, towing a trailer [307](#)
Eye for towing [371](#)
Eyes, see Lashing eye in the luggage compartment [293](#)
- F**
- Factory settings, see Resetting vehicle data [71](#)
Failure message, see Check Control [156](#)
False warnings, see Avoiding false warnings [103](#)
Fastening seat belts, see Seat belts [113](#)
Fatigue warning function [217](#)
Fault displays, see Check Control [156](#)
Filter, see Interior filter [280](#)
- Finding charging stations, see Owner's Handbook for Navigation, Entertainment, Communication [6](#)
Fine wood parts, care [376](#)
Fire extinguisher [368](#)
First-aid kit [364](#)
Flank view [256](#)
Flat tyre, continuing a journey [343](#), [347](#)
Flat tyre, flat tyre monitor RPA [345](#)
Flat tyre message, RPA [345](#)
Flat tyre message, Tyre Pressure Monitor [341](#)
Flat tyre monitor RPA [345](#)
Flat tyre, remedying [333](#)
Flat tyre, see Tyre Pressure Monitor [338](#)
Flat tyre warning lamp, RPA [345](#)
Flat tyre warning light, Tyre Pressure Monitor [341](#)
Flat tyre, wheel change [347](#)
Flexible Fast Charger [319](#)
Flood, driving through [299](#)
Floor carpet, care [377](#)
Fold-out position, windscreen wiper [151](#)
Foot brake [299](#)
Foot mats, care [377](#)
Fording depth, water [299](#)
Four-wheel drive, see xDrive [223](#)
Front airbags [186](#)
Front-collision warning [192](#)
Front head rests [116](#)
Front neck supports, see Front head rests [116](#)
Front passenger's side exterior mirror, tilting down, see Automatic parking function [120](#)
Front passenger airbags, deactivating/activating [188](#)
Front passenger airbags, indicator lamp [189](#)
Front seats [110](#)
Fuses [363](#)
- G**
- General driving notes [298](#)
Give way warning [207](#)
Glare protection, see Sun visor [282](#)
Glass sunroof [106](#)
Glass sunroof, initialising system [109](#)
Glove compartment [288](#)

GPS, navigation, see Owner's Handbook for Navigation, Entertainment, Communication [6](#)
Guest profile, see BMW ID [71](#)

H

Handbrake, see Parking brake [145](#)
Hands-free system, see Owner's Handbook for Navigation, Entertainment, Communication [6](#)
Hazard warning lights [364](#)
Head airbag [186](#)
Head Light, adaptive [181](#)
Headlight flasher [149](#)
Headlight glass [361](#)
Headlights, care [374](#)
Headliner [46](#)
Head restraints and seats [110](#)
Head-Up Display [174](#)
Head-Up Display, care [377](#)
Head-Up Display, saving position, see Memory function [121](#)
Heavy transported loads, stowing [292](#)
Height, vehicle [378](#)
Help in case of a breakdown [364](#)
High beam assistant [182](#)
High-beam headlights [149](#)
High-voltage battery, alarm signal [21](#)
High-voltage battery, charging status display [163](#)
High-voltage battery, heavily discharged [141](#)
High-voltage battery, long stationary periods [325](#)
High-voltage battery, overheated [141](#)
High-voltage battery, recycling [359](#)
High-voltage battery, service life [325](#)
High-voltage system, automatic deactivation [22](#)
High-voltage system, contact with water [21](#)
High-voltage system, safety [21](#)
High-voltage system, work [21](#)
Holder for drinks, front [290](#)
Holder for drinks, rear [290](#)
Home lights [179](#)
Home lights, switching on [179](#)
Home page, see Internet [6](#)
Horn [42](#)
Hotel function, see Parking service mode [99](#)

Hour, see Time [165](#)

I

iBrake – PostCrash [217](#)
Ice, see Outside temperature [165](#)
Ice warning, see Outside temperature [165](#)
Iconic sounds, see Drive sound [272](#)
ID, charging cable [318](#)
Identification number, see Vehicle identification number [19](#)
iDrive [54](#)
Ignition key, see Vehicle key [84](#)
Important considerations [124](#)
Increasing range [309](#)
Indicator lamp, front passenger airbags [189](#)
Indicator light on the charging socket outlet, see Charging status display [322](#)
Indicator lights [157](#)
Individual air distribution [278](#)
Individual settings, see BMW ID [71](#)
Inductive charging, smartphone, see Wireless charging dock [285](#)
Inflation pressure, tyres [327](#)
Inflation pressure warning RPA, tyres [345](#)
Initialising, runflat indicator RPA [345](#)
Input comparison [56](#)
Input, iDrive [55](#)
Instrument cluster [153](#)
Instrument cluster switch, see Turn indicators [148](#)
Instrument cluster switch, see Wiper system [149](#)
Instrument lighting [184](#)
Instrument panel, see Instrument cluster [153](#)
Integrated key [85](#)
Integrated Owner's Handbook in the vehicle [23](#)
Intelligent emergency call [367](#)
Intelligent Personal Assistant [61](#)
Intended use [8](#)
Interior equipment [282](#)
Interior filter [280](#)
Interior light [184](#)
Interior light with the vehicle locked [179](#)
Interior mirror [120](#)
Interior mirror, external [119](#)

Interior mirror, manual dim [120](#)
Interior movement detector [103](#)
Internet site [6](#)
Interval Display, see Service requirements [166](#)
i-Size child restraint systems [127](#)
ISOFIX, child safety seat fasteners [126](#)

J

Jacking points [350](#)
Journey data [171](#)
Jump starting, see Starting aid [370](#)
Junction warning, see Road priority warning [207](#)

K

Kenaf, care [376](#)
Key Card [95](#)
Key, mechanical [85](#)
Key, see Vehicle key [84](#)
Key switch for front passenger airbags [188](#)

L

Labelling of recommended tyres [331](#)
Labelling of run-flat tyres [332](#)
Lane boundary, warning [199](#)
Lane change assistant [246](#)
Lane Change Warning [202](#)
Lane control assistant, see Steering and lane control assistant [241](#)
Lane control assistant with active side collision protection, see Side collision warning [205](#)
Lane Departure Warning [199](#)
Language, setting [63](#)
Laser high-beam headlights [183](#)
Lashing eyes in the luggage compartment [293](#)
Lashing straps, see Lashing eyes in the luggage compartment [293](#)
Lateral Parking Aid [255](#)
Launch Control [143](#)
Leather care [375](#)
LED headlights, replacing, see Lights and bulbs [360](#)
Left-hand traffic, light setting [184](#)
Length, vehicle [378](#)

Light-alloy wheels, care [376](#)
Lighter [283](#)
Lighter, front [283](#)
Light in exterior mirror, see Crossing traffic warning [212](#)
Lighting [177](#)
Light in the exterior mirror, see Lane Change Warning [202](#)
Lights [177](#)
Light switch [177](#)
LIM button, see Manual Speed Limiter [224](#)
List, instrument cluster, see Selection lists [170](#)
Live Vehicle [171](#)
Load [292](#)
Loading the luggage compartment, see Stowing transported loads [292](#)
Loads [292](#)
Local time, see Time [165](#)
Locking, automatic [101](#)
Locking, doors and windows [133](#)
Locking, see Opening and closing [84](#)
Locking settings [100](#)
Locking wheel bolts [349](#)
Lock, power window switches, see Safety switch [105](#)
Lock, wheel bolts [349](#)
Logging on, mobile devices, see Connections [75](#)
Long stationary periods, high-voltage battery [325](#)
Low-beam headlight, operation [178](#)
Lower back support, see Lumbar support [113](#)
Luggage compartment [292](#)
Luggage compartment cover [295](#)
Luggage compartment, extending [294](#)
Luggage rack, see Roof rack [300](#)
Lumbar support [113](#)

M

Maintenance [357](#)
Maintenance requirements, see Condition Based Service CBS [357](#)
Maintenance, see Service requirements [166](#)
Maintenance System, BMW [357](#)
Make-up mirror [282](#)

Malfunction displays, see Check Control [156](#)
Malfunction, vehicle key [87](#)
Managing devices [76](#)
Manual operation, air distribution [278](#)
Manual operation, amount of air [277](#)
Map update, see Owner's Handbook for Navigation, Entertainment, Communication [6](#)
Matt paintwork, care [375](#)
Maximum cooling [277](#)
Maximum speed, display, see Speed Limit Info [167](#)
Maximum speed, winter tyres [331](#)
Media of the Owner's Handbook [23](#)
Medical supplies, see First-aid kit [364](#)
Memory function [121](#)
Messages, see Check Control [156](#)
Metres, see Instrument cluster [153](#)
Minimum tread depth, tyres [329](#)
Mirror, vanity [282](#)
Mobile communication in the vehicle [299](#)
Mobile devices, managing [76](#)
Mobile phone, see Owner's Handbook for Navigation, Entertainment, Communication [6](#)
Mobile Service, see BMW Accident Assistance [365](#)
Mobile Service, see BMW Roadside Assistance [365](#)
Mobile telephone, connecting [75](#)
Mobile telephone, see Owner's Handbook for Navigation, Entertainment, Communication [6](#)
Mobility system, see Tyre repair kit [333](#)
Mode 2 charging cable [318](#)
Mode 2 charging, see Vehicle charging [316](#)
Mode 3 charging cable [318](#)
Mode 4 charging cable, see DC charging cable [318](#)
MODE button, see Active Cruise Control [229](#)
Moisture in the headlights, see Headlight glass [361](#)
Monitoring of the high-voltage battery [21](#)
Monitor, see Control display [57](#)
Mounting child restraints [125](#)
MP3 player, see Owner's Handbook for Navigation, Entertainment, Communication [6](#)
M suspension, adaptive, see Adaptive M suspension [271](#)

Multifunction hook [293](#)
Multifunction steering wheel, buttons [42](#)
Multimedia, see Owner's Handbook for Navigation, Entertainment, Communication [6](#)
N
Navigation, see Owner's Handbook for Navigation, Entertainment, Communication [6](#)
Net, luggage compartment [293](#)
Neutral cleaner, see Light-alloy wheels, care [376](#)
No-overtaking indicator [167](#)
No Passing information, see Speed Limit Display with no-overtaking indicator [167](#)
Notes [6](#)
Nylon rope for tow-starting/towing [371](#)

O

OBD, see On-board diagnosis, OBD [358](#)
Obstacle marker, Reversing Assist camera [254](#)
Odometer, see Journey data [171](#)
OFF display, instrument cluster, see Standby state and Drive-ready state [164](#)
On-board computer, see Journey data [171](#)
On-board diagnosis, OBD [358](#)
On-board literature, printed [23](#)
On-board monitor, see Control display [57](#)
On-board tool kit [360](#)
Opening and closing [84](#)
Opening with a smartphone, see BMW Digital Key [96](#)
Opening with the Key Card [95](#)
Operating condition of the vehicle [51](#)
Operating menus, iDrive [54](#)
Operating principle, iDrive [54](#)
Operation via voice control [61](#)
Optional equipment, see Vehicle equipment [7](#)
Outlets, see Ventilation [279](#)
Outside air, see Automatic air recirculation control [277](#)
Outside temperature [165](#)
Owner's Handbook on language, BMW Intelligent Personal Assistant [63](#)
Owner's Handbook, printed [23](#)

P

Paintwork, vehicle care [375](#)
 Panorama View [257](#)
 Panorama View, see Panorama View [257](#)
 Panoramic glass sunroof, see Glass sunroof [106](#)
 Park Assist [264](#)
 Park Distance Control [260](#)
 Parking aid, see Park Distance Control [260](#)
 Parking assistance systems [251](#)
 Parking assistant [264](#)
 Parking Assistant Plus, see Parking assistance systems [251](#)
 Parking Assistant, see Parking assistance systems [251](#)
 Parking brake [145](#)
 Parking brake function, Active Park Distance Control [263](#)
 Parking lights [178](#)
 Parking service mode [99](#)
 Parking with Automatic Hold [147](#)
 Part replacement [360](#)
 Parts and accessories [9](#)
 Payload, technical data [379](#)
 PDC, see Park Distance Control [260](#)
 Pedestrian protection, active [189](#)
 Pedestrian Warning, see Front-collision warning [192](#)
 Performance Control [271](#)
 Performance display, instrument cluster [163](#)
 Personal Assistant [61](#)
 Personal data, deleting [70](#)
 Personal eSIM [79](#)
 Personal hotspot [80](#)
 Personal profile, see BMW ID [71](#)
 Personal settings [70](#)
 Physical units, see Set units of measurement [165](#)
 Place for children [124](#)
 Plasters, see First-aid kit [364](#)
 Plastic parts, care [376](#)
 Pop-ups, control display [56](#)
 PostCrash – iBrake [217](#)
 Power display, see Sport displays [174](#)
 Power failure [362](#)
 Powermeter, see Performance display [163](#)

Power window switches [103](#)
 Preliminary air conditioning, see Stationary air conditioning [280](#)
 Pressure, tyres [327](#)
 Pressure warning RPA, tyres [345](#)
 Printed on-board literature [23](#)
 Protection for pedestrians, acoustic [136](#)
 Protection function, glass sunroof, see Anti-trap mechanism [108](#)
 Protection function, windows, see Anti-trap mechanism [105](#)

Q

Quick charge cable, see Mode 3 charging cable [318](#)

R

Racetrack [302](#)
 Radar sensors, see Sensors of the vehicle [47](#)
 Radio, see Owner's Handbook for Navigation, Entertainment, Communication [6](#)
 Radio signals [299](#)
 Rain sensor [150](#)
 Range [165](#)
 READY display, instrument cluster, see Standby state and Drive-ready state [164](#)
 Rear automatic air conditioning [273](#)
 Rear Collision Prevention [206](#)
 Rear collision warning, see Rear Collision Prevention [206](#)
 Rear fog light [183](#)
 Rear fog light, replacing, see Lights and bulbs [360](#)
 Rear head rests [117](#)
 Rear luggage rack [301](#)
 Rear neck supports, see Rear head rests [117](#)
 Rear seat backrests, folding down [294](#)
 Rear-view mirror with automatic anti-dazzle function [120](#)
 Rear window heating [279](#)
 Recirculated-air mode [277](#)
 Recirculation, see Recirculated-air mode [277](#)
 Recommended makes of tyre [331](#)
 Recuperation, see Energy recuperation [136](#)

- Recycling [359](#)
- Recycling, high-voltage battery [359](#)
- Reduced drive power, see Heavily discharged high-voltage battery [166](#)
- Registering a device [75](#)
- Remaining range, see Range [165](#)
- Remote 3D View [259](#)
- Remote control for audio, see Owner's Handbook for Navigation, Entertainment, Communication [6](#)
- Remote control, see Vehicle key [84](#)
- Remote services, app, see Owner's Handbook for Navigation, Entertainment, Communication [6](#)
- Remote Software Upgrade [66](#)
- Renewal, wheels and tyres [330](#)
- Replacement of parts [360](#)
- Replacement, wheels and tyres [330](#)
- Replacing bulbs, see Lights and bulbs [360](#)
- Replacing front lights, see Bulbs and lights [360](#)
- Replacing headlights, see Bulbs and lights [360](#)
- Replacing laser headlights, see Bulbs and lights [360](#)
- Replacing light-emitting diodes, see Bulbs and lights [360](#)
- Replacing lights, see Bulbs and lights [360](#)
- Replacing parts [360](#)
- Replacing rear light, see Bulbs and lights [360](#)
- Replacing tail lights, see Bulbs and lights [360](#)
- Replacing the wiper blades [360](#)
- RES CNCL button, Active Cruise Control [229](#)
- RES CNCL button, cruise control [226](#)
- Reserve warning, see Range [165](#)
- Reservoir for washer fluid [355](#)
- Resetting settings, vehicle [71](#)
- Resetting, Tyre Pressure Monitor [340](#)
- Resetting, vehicle data [71](#)
- Reset, Tyre Pressure Monitor [340](#)
- Reset, vehicle settings [71](#)
- Restraint systems for children, see Carrying children safely [124](#)
- Restricted Driving, see BMW Digital Key [96](#)
- Rest state, see Operating condition of the vehicle [51](#)
- RESUME button, Active Cruise Control [229](#)
- RESUME button, cruise control [226](#)
- Retreaded tyres [331](#)
- Reuse [359](#)
- Reversing assistant [269](#)
- Reversing Assist camera [255](#)
- Right-hand traffic, light setting [184](#)
- Road priority warning [207](#)
- Roadside Assistance, see BMW Roadside Assistance [365](#)
- Roller cover [295](#)
- Rolling away in idle, see Coasting [313](#)
- Roof load, permitted [379](#)
- Roof rack [300](#)
- Rope for tow-starting/towing [371](#)
- Roundabout light [181](#)
- Route, navigation, see Owner's Handbook for Navigation, Entertainment, Communication [6](#)
- RPA flat tyre monitor [345](#)
- RSC Runflat System, see Run-flat tyres [332](#)
- RTTI, see Owner's Handbook for Navigation, Entertainment, Communication [6](#)
- Rubber parts, care [376](#)
- Run Flat, see Run-flat tyres [332](#)
- Run-flat tyres [332](#)
- Running in [298](#)

S

- Safe seating position [110](#)
- Safe Share function, see BMW Digital Key [96](#)
- Safety of the high-voltage system [21](#)
- Safety package, see Active Protection [216](#)
- Safety switch, windows [105](#)
- Safety systems, see Airbags [186](#)
- Safety systems, see Collision warning systems [191](#)
- Saving mirror position, see Memory function [121](#)
- Saving seat position, see Memory function [121](#)
- Saving steering wheel position, see Memory function [121](#)
- Screen, see Control display [57](#)
- Sealing compound, see Tyre repair kit [333](#)
- Seat belt reminder for driver and front passenger seat [115](#)
- Seat belts [113](#)
- Seat belts, care [376](#)

- Seat heating [122](#)
- Seats and head restraints [110](#)
- Seats, front [110](#)
- Securing, transported loads [292](#)
- Selection list in the instrument cluster [170](#)
- Selector lever position [138](#)
- Selector lever position B, Brake [139](#)
- Sensors, care [377](#)
- Sensors of the vehicle [47](#)
- Service history [167](#)
- Service life of the high-voltage battery [325](#)
- Service requirements [166](#)
- Service requirements, see Condition Based Service CBS [357](#)
- Services, ConnectedDrive, see Owner's Handbook for Navigation, Entertainment, Communication [6](#)
- Service, see BMW Accident Assistance [365](#)
- Service, see BMW Roadside Assistance [365](#)
- Servotronic [223](#)
- SET button, Active Cruise Control [229](#)
- SET button, cruise control [226](#)
- Set clock [165](#)
- Set day, see Date [165](#)
- Set system language, see Language [63](#)
- Set time, see Time [165](#)
- Setting, control display [57](#)
- Settings, locking/unlocking [100](#)
- Settings, seats and head restraints [110](#)
- Settings, steering wheel [121](#)
- Set units of measurement [165](#)
- Shock absorber adjustment, active, see Adaptive M suspension [271](#)
- Shortcuts, iDrive [56](#)
- Side airbag [186](#)
- Side collision warning [205](#)
- Side lights [178](#)
- Side nozzles, see Ventilation [279](#)
- Side protection, see Lateral Parking Aid [255](#)
- Signal horn, horn [42](#)
- Signals on unlocking, see Acknowledgement signals [101](#)
- Sign, charging cable [318](#)
- Sizes, see Dimensions [378](#)
- Slipperiness, see Outside temperature [165](#)
- Slippery road, see Outside temperature [165](#)
- Smallest turning radius, vehicle [378](#)
- Smartphone, connecting [75](#)
- Smartphone integration, Android Auto preparation [81](#)
- Smartphone integration, Apple CarPlay preparation [80](#)
- Smartphone, operating via voice control [64](#)
- Smartphone, see Owner's Handbook for Navigation, Entertainment, Communication [6](#)
- Smokers package [282](#)
- SMS, see Short messages, see Owner's Handbook for Navigation, Entertainment, Communication [6](#)
- Snow chains [337](#)
- Socket for on-board diagnosis OBD [358](#)
- Sockets, electrical devices [283](#)
- Software update, see Remote Software Upgrade [66](#)
- Software upgrade, see Remote Software Upgrade [66](#)
- Software version, see Remote Software Upgrade [66](#)
- SOS button, see Intelligent emergency call [367](#)
- SOS button, see Statutory emergency call [366](#)
- Sound of drivetrain [272](#)
- Sound output, see Owner's Handbook for Navigation, Entertainment, Communication [6](#)
- Sound, see Owner's Handbook for Navigation, Entertainment, Communication [6](#)
- Spanner, see On-board tool kit [360](#)
- Speech recognition [61](#)
- Speed Limit Assist [237](#)
- Speed Limit Device, Manual Speed Limiter [224](#)
- Speed limit display, see Speed Limit Info [167](#)
- Speed limiter, manual [224](#)
- Speed Limit Info [167](#)
- Speed warning [224](#)
- SPORT BOOST, see Driving Experience Control [144](#)
- Sport displays [174](#)
- SPORT INDIVIDUAL, see Driving Experience Control [144](#)
- SPORT, see Driving Experience Control [144](#)
- Sport steering, variable [223](#)
- Sport suspension, see Adaptive M suspension [271](#)

- Stability control systems [220](#)
Standard charging cable [318](#)
Standard charging, see [Vehicle charging 316](#)
Standard equipment, see [Vehicle equipment 7](#)
Standby state, see [Operating condition of the vehicle 51](#)
Start/Stop button [137](#)
Starting aid [370](#)
Starting the engine with the Key Card [95](#)
Stationary air conditioning [280](#)
Stations, AM/FM, see [Owner's Handbook for Navigation, Entertainment, Communication 6](#)
Status indicator, tyres [340](#)
Status information, iDrive [55](#)
Status of the Owner's Handbook [8](#)
Status, vehicle [174](#)
Statutory emergency call [366](#)
Steering and lane control assistant [241](#)
Steering assistance, see [Servotronic 223](#)
Steering column adjustment [121](#)
Steering wheel, buttons [42](#)
Steering wheel heating [121](#)
Steering wheel, setting [121](#)
Storage, charge cables [319](#)
Storage compartment, centre console [289](#)
Storage compartments [288](#)
Storage, tyres [332](#)
Stowing charging cables, see [Storage 319](#)
Stowing, transported loads [292](#)
Suitable devices [76](#)
Suitable mobile telephones [76](#)
Summer tyres, tread [329](#)
Sun visor [282](#)
Sun visor, moveable [282](#)
Supplementary Owner's Handbook [23](#)
Suspension, electronic, see [Adaptive M suspension 271](#)
Suspension settings, see [Driving Experience Control 144](#)
Swinging of the trailer, see [Trailer Stability Control 305](#)
Switches, see [Vehicle cockpit 42](#)
Switch for driving dynamics, see [Driving Experience Control 144](#)
Switching off drive-ready state [137](#)
Switching on drive-ready state [137](#)
Symbols and displays [7](#)
SYNC program, automatic air conditioning [278](#)
- ## T
- Tailgate, emergency release [95](#)
Technical changes, see [Your own safety 8](#)
Technical data [378](#)
Telephone, connecting [75](#)
Telephone, see [Owner's Handbook for Navigation, Entertainment, Communication 6](#)
Telephone, selection list in the instrument cluster [170](#)
Teleservices, see [Owner's Handbook for Navigation, Entertainment, Communication 6](#)
Television, TV, see [Owner's Handbook for Navigation, Entertainment, Communication 6](#)
Temperature, automatic air conditioning [276](#)
Temperature display, see [Outside temperature 165](#)
Temperature preconditioning, see [Stationary air conditioning 280](#)
Tension belt, see [Lashing eyes in the luggage compartment 293](#)
Thigh support [112](#)
Tilt alarm sensor [103](#)
Tilting down the front passenger's side exterior mirror, see [Automatic parking function 120](#)
Time [165](#)
Time of day, see [Time 165](#)
Time setting, automatic [165](#)
Time zone [165](#)
Tools [360](#)
Torque display, see [Sport displays 174](#)
Total weight, permitted [379](#)
Total weight, trailer operation [379](#)
Touchpad, Controller [59](#)
Tourist function, see [Right-hand/left-hand traffic 184](#)
Tow bar [371](#)
Tow fitting, see [Towing eye 371](#)
Towing a trailer [303](#)
Towing a trailer, activation [306](#)
Towing a trailer, technical data [379](#)
Towing away [370](#)
Towing eye [371](#)

- Towing rope [371](#)
Towing, see [Towing away 370](#)
Traction control [222](#)
TRACTION, driving dynamics [222](#)
Traffic information, see [Owner's Handbook for Navigation, Entertainment, Communication 6](#)
Traffic jam assistant, see [Assisted Driving Plus 244](#)
Traffic light detection [239](#)
Traffic-queue assistant, see [Assisted Driving Plus 244](#)
Trailer loads [379](#)
Trailer nose weight, technical data [379](#)
Trailer Stability Control [305](#)
Trailer tow hitch, ball linkage electrically swivellable [306](#)
Trailer tow hitch, zoom [257](#)
Transmission lockout, unlocking electronically [140](#)
Transported loads, stowing and securing [292](#)
Tread, tyres [329](#)
Trip distance recorder, see [Journey data 171](#)
Triple turn signal [148](#)
Turn indicator, indicator lamp [160](#)
Turn indicators, high-beam headlights, headlight flasher [148](#)
Turn indicators, replacing bulbs, see [Bulbs and lights 360](#)
Turning circle lines, Reversing Assist camera [254](#)
Turning radius, vehicle [378](#)
TV, see [Owner's Handbook for Navigation, Entertainment, Communication 6](#)
Tyre change [330](#)
Tyre damage [329](#)
Tyre inflation pressure [327](#)
Tyre makes, recommendation [331](#)
Tyre pressure [327](#)
Tyre Pressure Monitor [338](#)
Tyre pressure monitoring, see [RPA 345](#)
Tyre Pressure Monitor, reset [340](#)
Tyre Pressure Monitor, resetting [340](#)
Tyre pressure test, see [Tyre Pressure Monitor 338](#)
Tyre repair kit [333](#)
Tyres and wheels [327](#)
Tyre sealant, see [Tyre repair kit 333](#)
Tyre settings [339](#)
Tyres with emergency running properties [332](#)
Tyre tread [329](#)
- ## U
- UCC, see [Traffic light detection 239](#)
Ultrasonic sensors, see [Sensors of the vehicle 47](#)
Units, see [Set units of measurement 165](#)
Unloaded weight [379](#)
Unlocking, automatic [100](#)
Unlocking, see [Opening and closing 84](#)
Unlocking, settings [100](#)
Updates after going to press [8](#)
Upgrade, see [Remote Software Upgrade 66](#)
Upper retaining strap, top tether [128](#)
Urban Cruise Control, see [Traffic light detection 239](#)
USB connection [82](#)
USB port, position in the vehicle [284](#)
Use, intended [8](#)
- ## V
- Valet parking mode, see [Parking service mode 99](#)
Vanity mirror [282](#)
Variable sport steering [223](#)
Vehicle acknowledgement signals [101](#)
Vehicle battery [361](#)
Vehicle breakdown, see [Help in case of a breakdown 364](#)
Vehicle care [374](#)
Vehicle cockpit [42](#)
Vehicle data and data protection [10](#)
Vehicle data, resetting [71](#)
Vehicle equipment [7](#)
Vehicle identification number [19](#)
Vehicle key [84](#)
Vehicle key, additional [84](#)
Vehicle key, changing batteries [85](#)
Vehicle key, integrated key [85](#)
Vehicle key, loss [84](#)
Vehicle key, malfunction [87](#)

Vehicle paintwork, care [375](#)
Vehicle, running in [298](#)
Vehicle status [174](#)
Vehicle wash [373](#)
Ventilation [279](#)
Ventilation, see Stationary air conditioning [280](#)
Video recording, see BMW Drive Recorder [214](#)
Video, see Owner's Handbook for Navigation,
Entertainment, Communication [6](#)
VIN, see Vehicle identification number [19](#)
Voice control [61](#)
Voice control, see BMW Intelligent Personal As-
sistant [61](#)
Voice control system [61](#)
Voice input [61](#)

W

Wake word [62](#)
Warning function, rear-end collision [206](#)
Warning function with wrong direction of travel,
see Wrong-way Warning [209](#)
Warning lamp in exterior mirror, see Crossing
traffic warning [212](#)
Warning lamp in the exterior mirror, see Lane
Change Warning [202](#)
Warning lights [157](#)
Warning messages, see Check Control [156](#)
Warning of crossing traffic [212](#)
Warnings, false [103](#)
Warning systems in case of risk of collision [191](#)
Warning triangle [364](#)
Warranty [9](#)
Warranty Booklet [9](#)
Washer fluid [355](#)
Washing fluid, see Washer fluid [355](#)
Wash, vehicle [373](#)
Water, high-voltage system [21](#)
Water on streets [299](#)
Water, see Condensation when vehicle is
parked [300](#)
Website, see Internet [6](#)
Weights [379](#)
Welcome Light Carpet, see Welcome light [179](#)
Welcome lights [179](#)
Welcome screen, driver profiles [71](#)

Wheelbase, vehicle [378](#)
Wheel change [347](#)
Wheels and tyres [327](#)
Wheels and tyres, exchange [330](#)
Widgets, iDrive [55](#)
Width, vehicle [378](#)
Window, defrosting [278](#)
Windscreen, defrosting [278](#)
Windscreen washing system, see Wiper sys-
tem [149](#)
Windscreen wipers, see Wiper system [149](#)
Winter tyres [331](#)
Winter tyres, tread [329](#)
Wiper, fold-out position [151](#)
Wipers, see Wiper system [149](#)
Wiper system [149](#)
Wiping fluid, see Washer fluid [355](#)
Wireless charging dock for smartphones [285](#)
Wireless charging, smartphone, see Wireless
charging dock [285](#)
WLAN connection, see WiFi connection [78](#)
Wood parts, care [376](#)
Wordmatch principle, see Input comparison [56](#)
Work, high-voltage system [21](#)
Wrong-way Warning [209](#)

X

xDrive [223](#)

Y

Your own safety [8](#)



01405A48801 en



The Ultimate
Driving Machine



BMW DRIVER'S GUIDE APP.

Your customised vehicle information in an app.
Optimised for smartphones & tablets. Can be used offline.



01405A48801 en

